

VBC-ME21

2015 Mercedes Metris L2H1 Medium Wheel Base, Low Roof

Dimensional Specifications on Page 2

Configuration as shown:

Base Left/Clamp Down Right
Two Crossbars, US Gen4
Finish: White Powder Coat
Vehicle-Specific Mounting Bracket System
Rack Weight (empty): 37.50 lbs

Load specifications as shown:

Maximum Ladder Weight LH..... 100 lbs
Maximum Ladder Length LH..... 28 ft
Maximum Ladder Section LH 14 ft
Maximum Ladder Weight RH 75 lbs
Maximum Ladder Length RH 28 ft
Maximum Ladder Section RH..... 14 ft

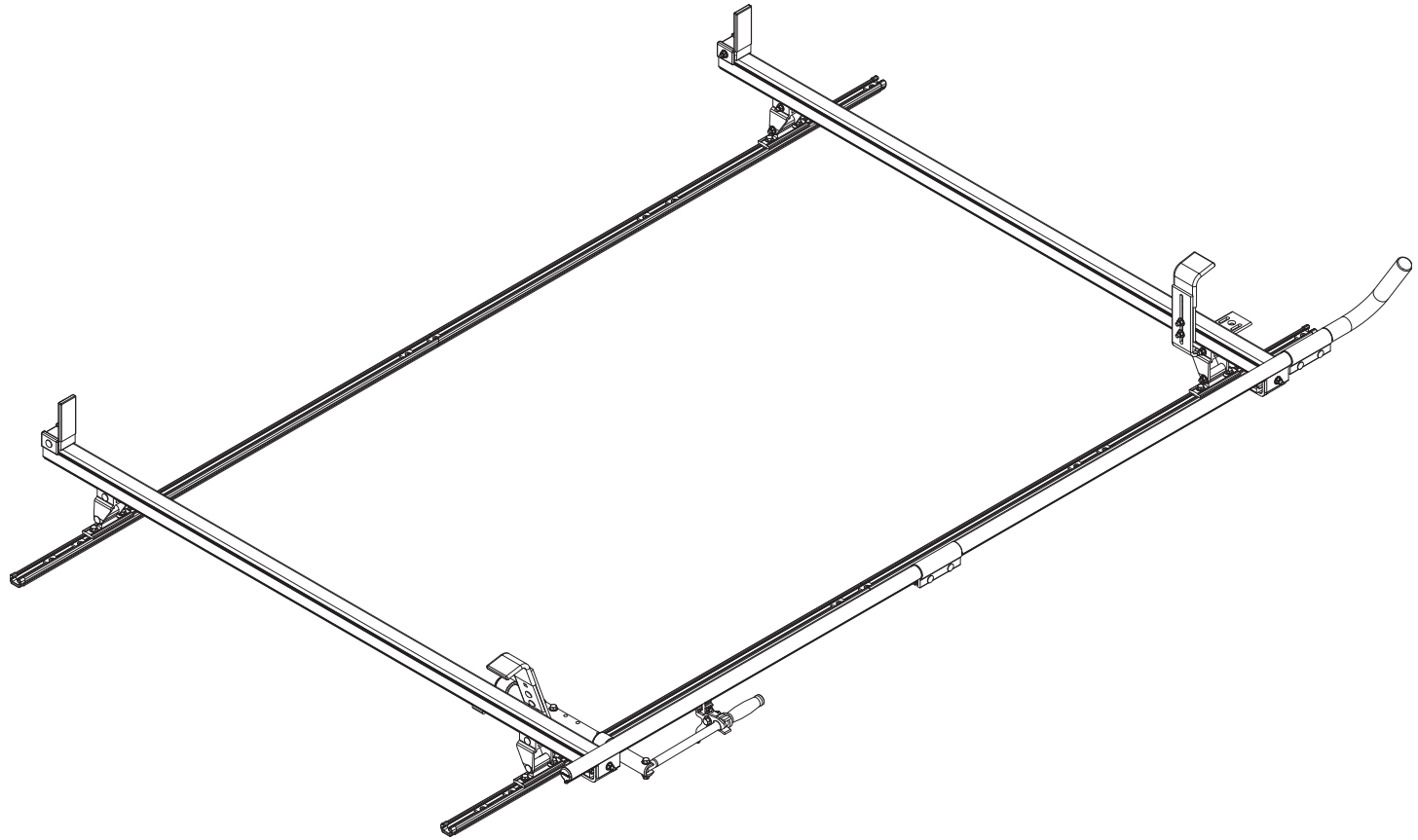

VBC-ME21

2015 Mercedes Metris L2H1
Medium Wheel Base, Low Roof

Approximate dimensions as shown:

A: Rack Width	74"
B: Mount Spacing L/R	54"
C: Crossbar Offset L-R	Even
D: Overall Height	89"
E: Rack Length	108"
F: Crossbar Spacing	7'
G: Rack Height	14"
H: Roof Height	75"
I: Wheel Base	126"

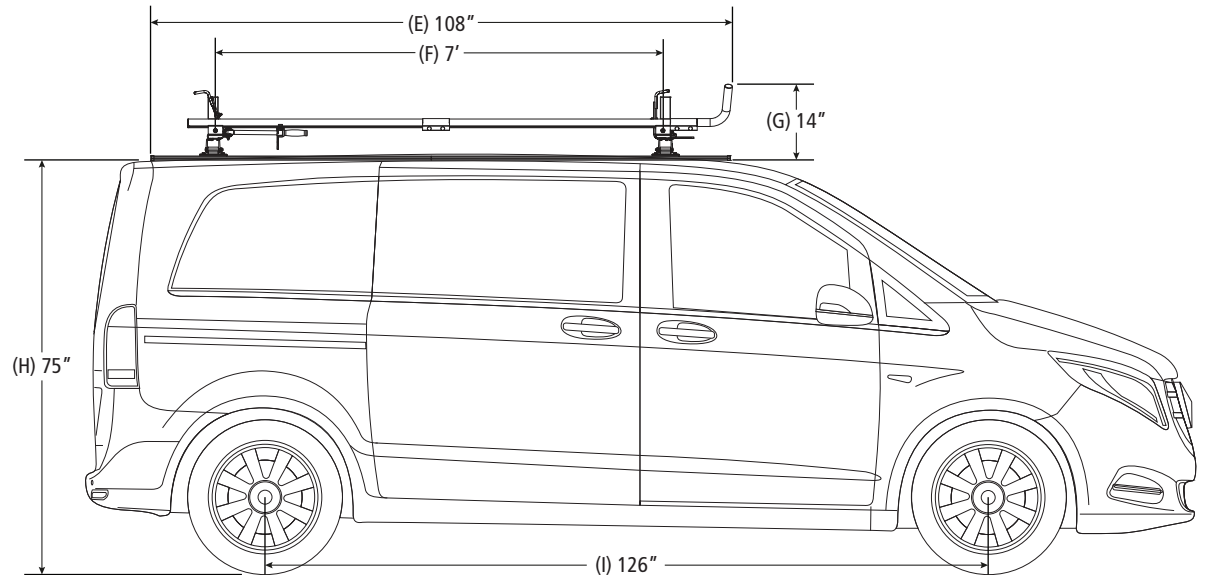
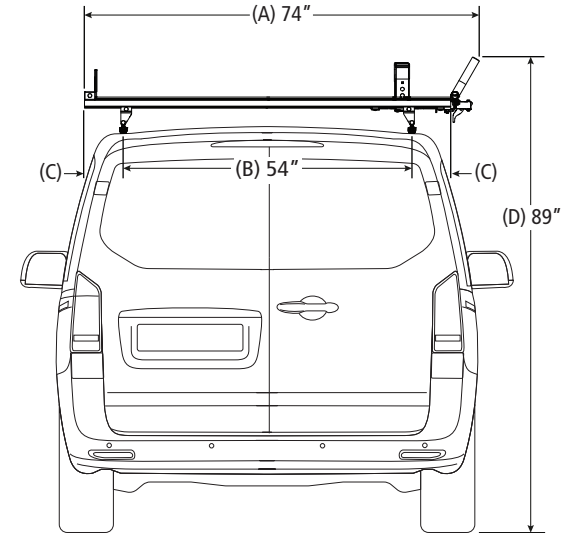
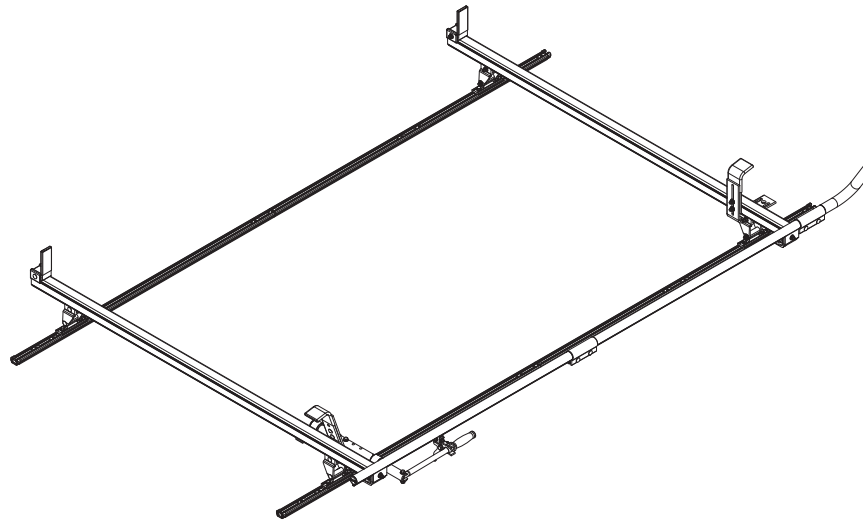

Assembly Manual also available:

VBC-ME21

USOV-VBCME21-US01 Rev-A 0118