

VBR-ME-M

ErgoRack, Mercedes Metris

Two Crossbars, Powder Coat Finish
Rack Weight (empty): 87 lbs

*Callouts in this Configuration Overview indicate full module assemblies only.

For details on individual parts, please refer to the linked Module Overviews below.

- A: [FEA-0001 End Stop Assembly](#)
- B: [FBM-1015-BLK Mounting System](#)
- C: [CBR-0003 Crossbar Assembly](#)
- D: [FEA-0002 Rotation Assembly](#)
- E: [FEA-0022 Rotation Feature](#)
- F: [FEA-0015 Rotation Driveshaft Feature](#)

[Modular Assembly Manuals](#)

ErgoRack Van—Load specifications:

Check vehicle manufacturer recommendations for roof capacity weight limits.

CROSSBAR SPACING	STEP LADDER	EXT. LADDER
4 ft Spacing	6 – 8 ft.	16 – 20 ft.
5 ft Spacing	8 – 10 ft.	16 – 24 ft.
6 ft Spacing	8 – 12 ft. [†]	16 – 28 ft.
7 ft Spacing	10 – 12 ft. [†]	20 – 32 ft.
8 ft Spacing	10 – 12 ft. [†]	20 – 36 ft.

[†]Rotation Configurations: 12 ft. step ladders require an extended upper add-on component.

*Example shown with 126" Wheelbase Configuration

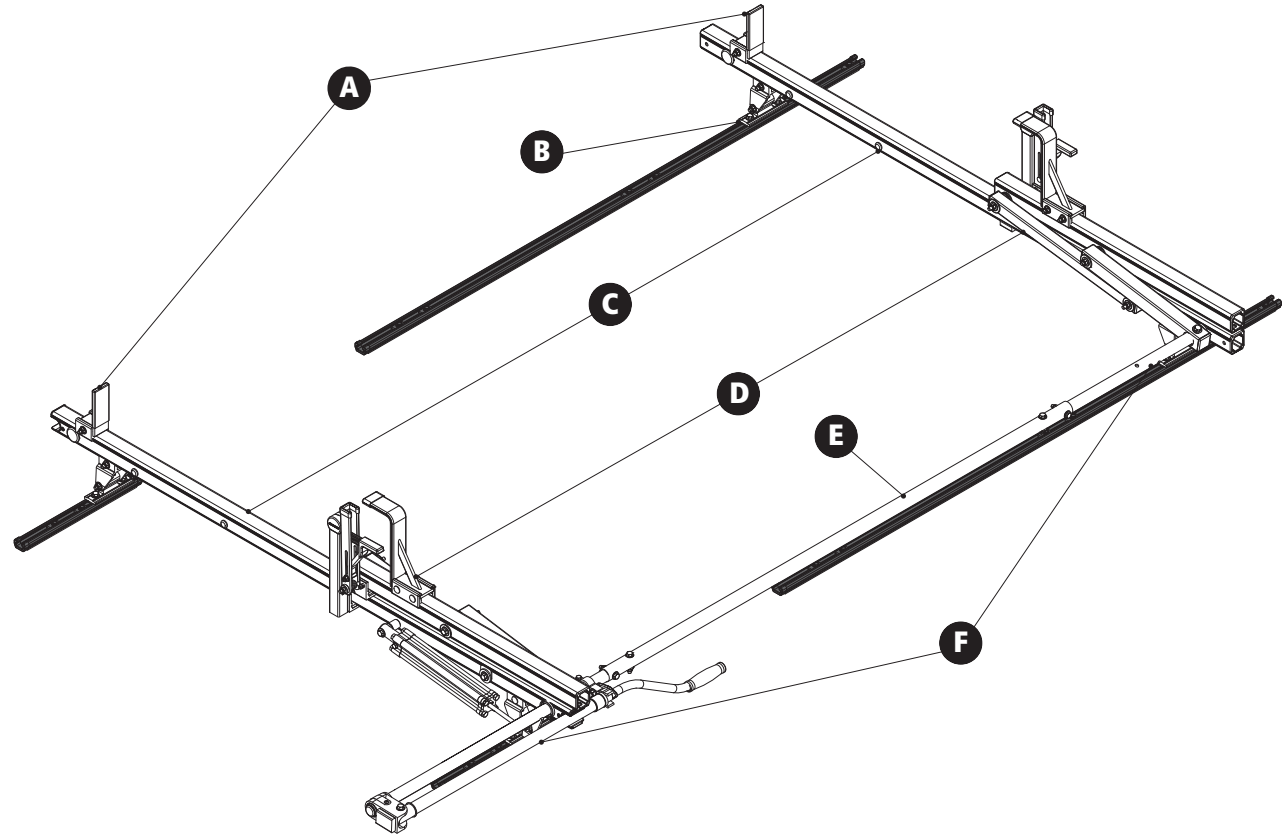

VBR-ME-M

ErgoRack, Mercedes Metris

Approximate dimensions as shown:

All Wheelbases

A: Rack Width	68"
B: Rack Height	17"
C: Rear Crossbar Offset (L&R)	Even
D: Mount Spacing L/R.....	Set at install

126" Wheelbase

E: Total Crossbar Spacing.....	6'-8'
F: Rack Length	120"

135" Wheelbase

G: Total Crossbar Spacing.....	6'-8'
H: Rack Length.....	132"

Compatible Accessories Available

(Sold Separately)

Retractable Ratchet Tie-Down	ACC-8000
Rear Access Ladder.....	AAL Series
8'-12' Conduit Carriers.....	CON Series
WorkPro LED Lighting.....	LED Series
Systems and Safety Components	RVS Series
Safety monitoring.....	DS2 Series

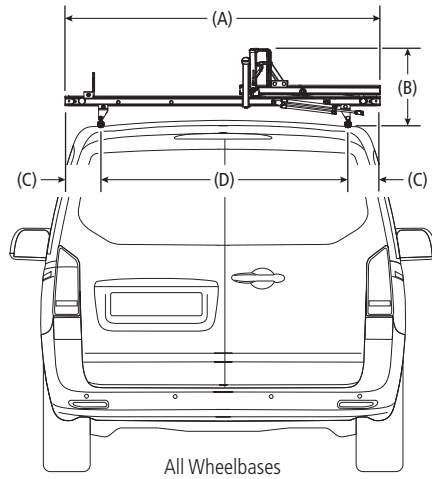

Rear Drive Shaft Offset: 24"

Note: The end of the driveshaft must not extend beyond the vehicle bumper

