

VRC3-ME-M

ErgoRack, Mercedes Metris

Three Crossbars, Powder Coat Finish
Rack Weight (empty): 102 lbs

*Callouts in this Configuration Overview indicate full module assemblies only.

For details on individual parts, please refer to the linked Module Overviews below.

- A: [FEA-0016 Rotation Driveshaft Feature](#)
- B: [FBM-1015-BLK Mounting System](#)
- C: [FEA-0002 Rotation Assembly](#)
- D: [CBR-0004 Crossbar Assembly](#)
- E: [CBR-0003 Crossbar Assembly](#)
- F: [FEA-0008 Clamp Down Assembly](#)

[Modular Assembly Manuals](#)

ErgoRack Van—Load specifications:

Check vehicle manufacturer recommendations for roof capacity weight limits.

CROSSBAR SPACING	STEP LADDER	EXT. LADDER
4 ft Spacing	6 – 8 ft.	16 – 20 ft.
5 ft Spacing	8 – 10 ft.	16 – 24 ft.
6 ft Spacing	8 – 12 ft. [†]	16 – 28 ft.
7 ft Spacing	10 – 12 ft. [†]	20 – 32 ft.
8 ft Spacing	10 – 12 ft. [†]	20 – 36 ft.

[†]Rotation Configurations: 12 ft. step ladders require an extended upper add-on component.

*Example shown with 126" Wheelbase Configuration

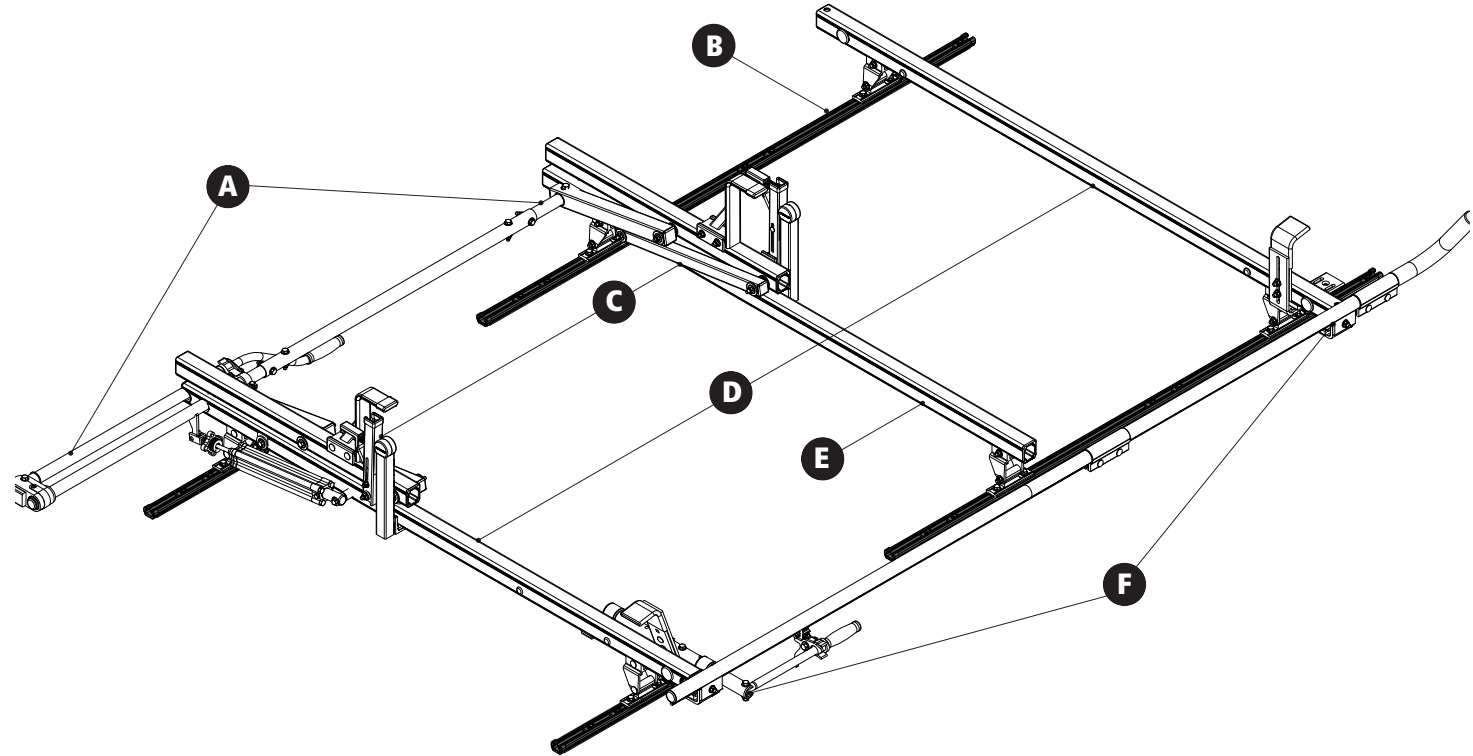

VRC3-ME-M

ErgoRack, Mercedes Metris

Approximate dimensions as shown:

All Wheelbases

- A: Rack Width 72"
- B: Rack Height 17"
- C: Rear Crossbar Offset (L&R) Even
- D: Mount Spacing L/R Set at install

126" Wheelbase

- E: Crossbar Spacing (rear to center) 4'
- F: Crossbar Spacing (center to front) 2'-4'
- G: Total Crossbar Spacing 6'-8'
- H: Rack Length 120" - 122"

135" Wheelbase

- I: Crossbar Spacing (rear to center) 4'
- J: Crossbar Spacing (center to front) 2'-4'
- K: Total Crossbar Spacing 6'-8'
- H: Rack Length 132" - 134"

Compatible Accessories Available

(Sold Separately)

- Rear Access Ladder [AAL Series](#)
- 8'-12' Conduit Carriers [CON Series](#)
- WorkPro LED Lighting [LED Series](#)
- Systems and Safety Components [RVS Series](#)
- Safety monitoring [DS2 Series](#)

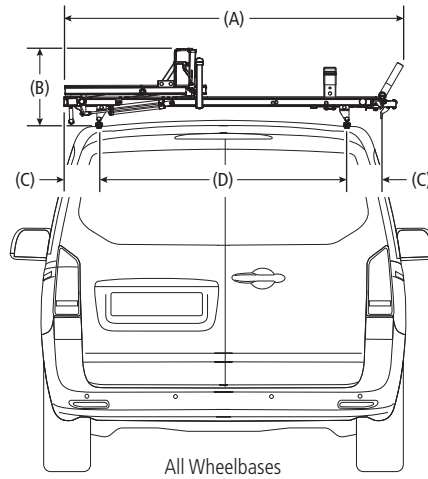

All Wheelbases

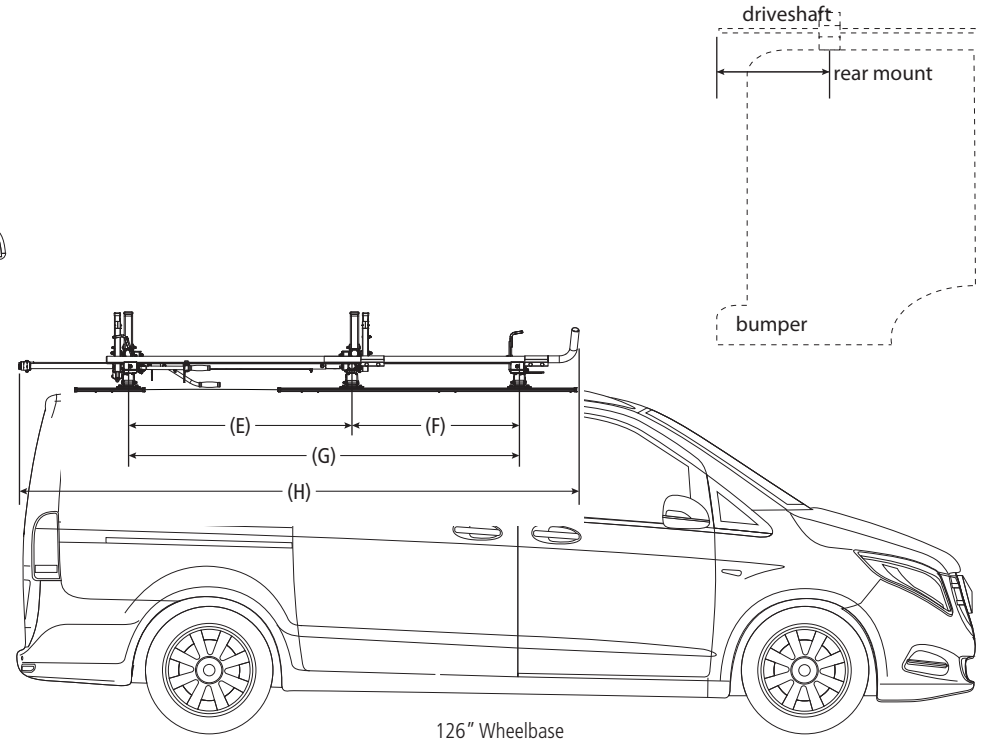

126" Wheelbase

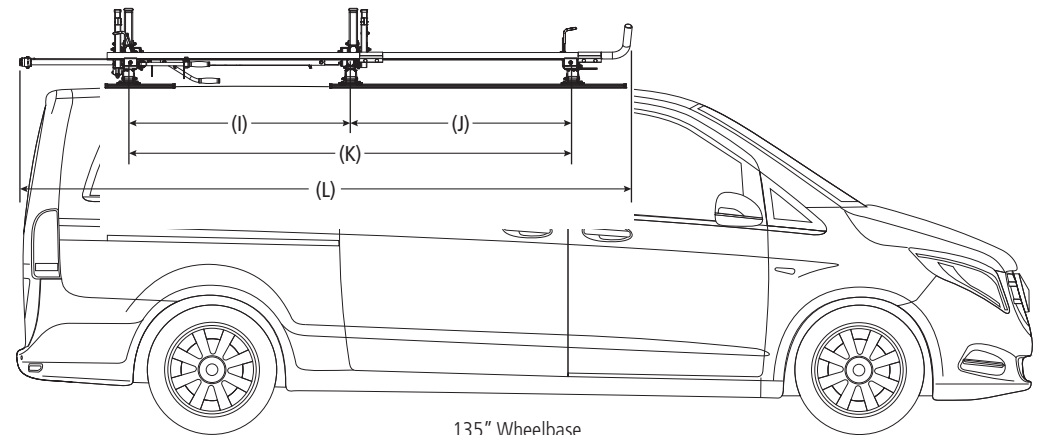

135" Wheelbase