

## VRR-FT-HM

### ErgoRack, Ford Transit Low Roof

Two Crossbars, Powder Coat Finish  
Rack Weight (empty): 109–114 lbs

\*Callouts in this Configuration Overview indicate full module assemblies only.

For details on individual parts, please refer to the linked Module Overviews below.

- A: ..... [FBM-1017-BLK Mounting System](#)
- B: ..... [CBA-3011 Hybrid Crossbar Assembly](#)
- C: ..... [FEA-0015 Rotation Driveshaft Feature](#)
- D: ..... [FEA-0016 Rotation Driveshaft Feature](#)

[Modular Assembly Manuals](#)

### ErgoRack Van—Load specifications:

Check vehicle manufacturer recommendations for roof capacity weight limits.

CROSSBAR SPACING	STEP LADDER	EXT. LADDER
4 ft Spacing	6 – 8 ft.	16 – 20 ft.
5 ft Spacing	8 – 10 ft.	16 – 24 ft.
6 ft Spacing	8 – 12 ft. <sup>†</sup>	16 – 28 ft.
7 ft Spacing	10 – 12 ft. <sup>†</sup>	20 – 32 ft.
8 ft Spacing	10 – 12 ft. <sup>†</sup>	20 – 36 ft.

<sup>†</sup>Rotation Configurations: 12 ft. step ladders require an extended upper add-on component.

\*Example shown with 130" Wheelbase Configuration

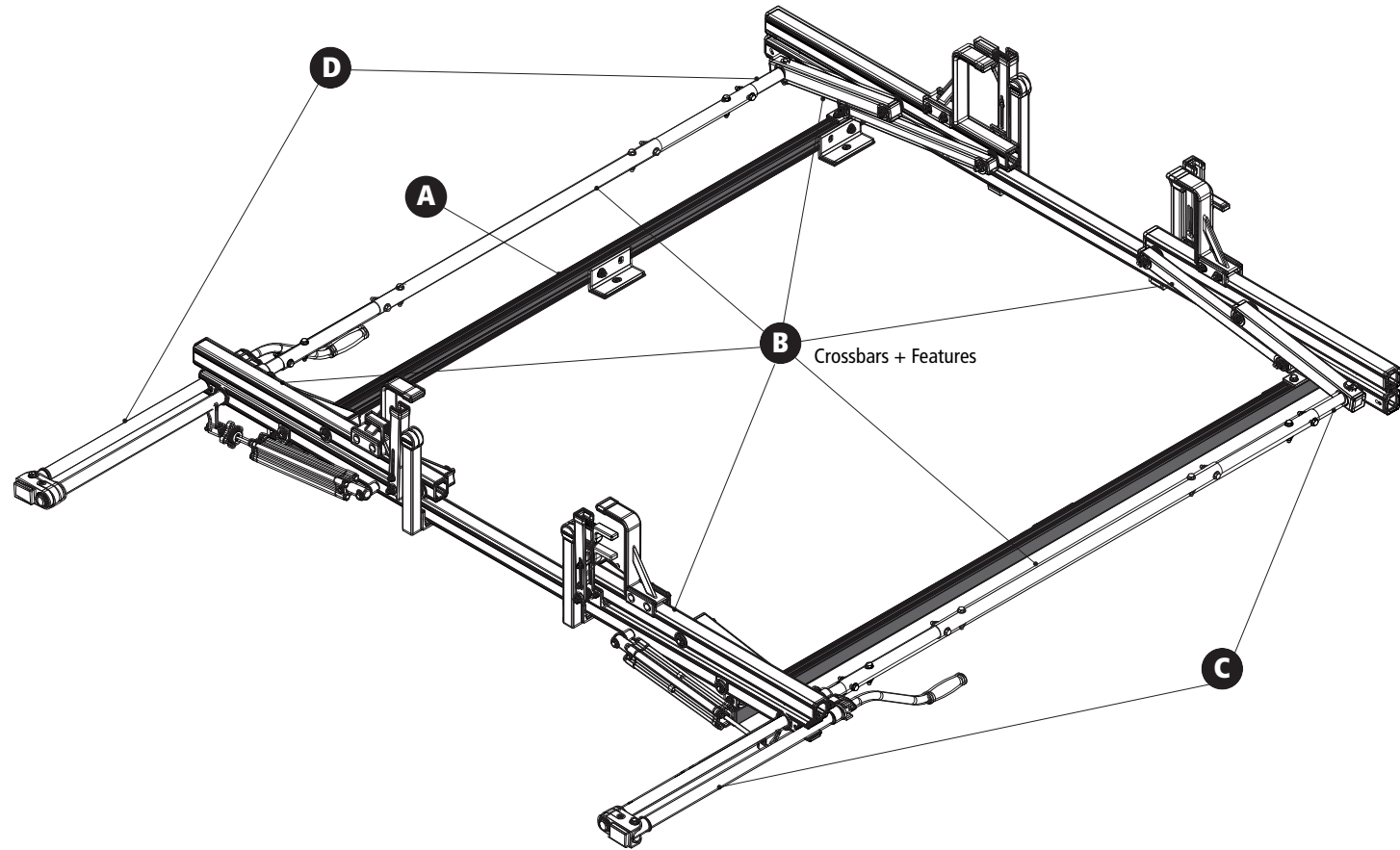

## VRR-FT-HM

### ErgoRack, Ford Transit Low Roof

Approximate dimensions as shown:

#### All Wheelbases

A: Rack Width .....	78"
B: Rack Height .....	16"
C: Rear Crossbar Offset (Left).....	10.25"
D: Mount Bolt Spacing L/R.....	56"



#### 130" Wheelbase

E: Total Crossbar Spacing.....	6'
F: Rack Length .....	100"

#### 148" Wheelbase

G: Total Crossbar Spacing .....	*6–8'
H: Rack Length.....	124"

\*5' Connecting Bars (sold separately) are required for spacings that exceed 6'—contact Sales & Service.

	3' Connecting Bar (Included in current configuration)
	5' Connecting Bar (Sold separately)

#### Compatible Accessories Available

(Sold Separately)

5' Rotation Connecting Bar .....	<a href="#">FEA-0022</a>
Rear Access Ladder.....	<a href="#">AAL Series</a>
8'–12' Conduit Carriers.....	<a href="#">CON Series</a>
WorkPro LED Lighting.....	<a href="#">LED Series</a>
Systems and Safety Components .....	<a href="#">RVS Series</a>
Safety monitoring.....	<a href="#">DS2 Series</a>

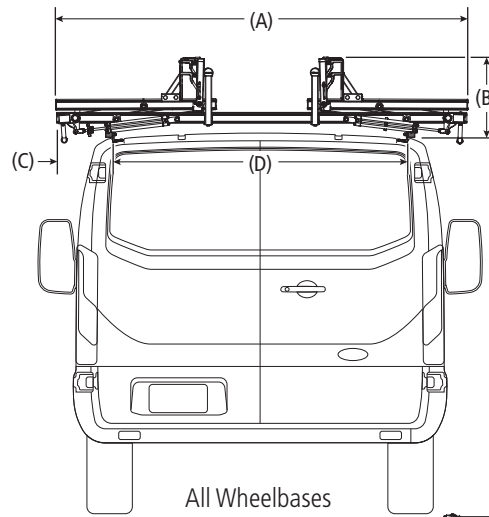

Rear Drive Shaft Offset: 24"

Note: The end of the driveshaft must not extend beyond the vehicle bumper

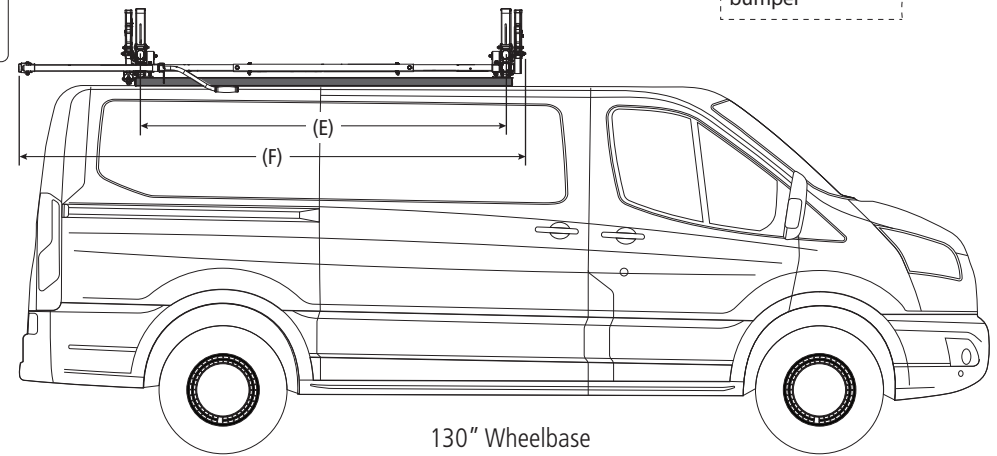
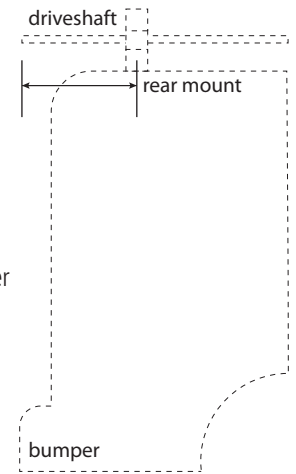

130" Wheelbase

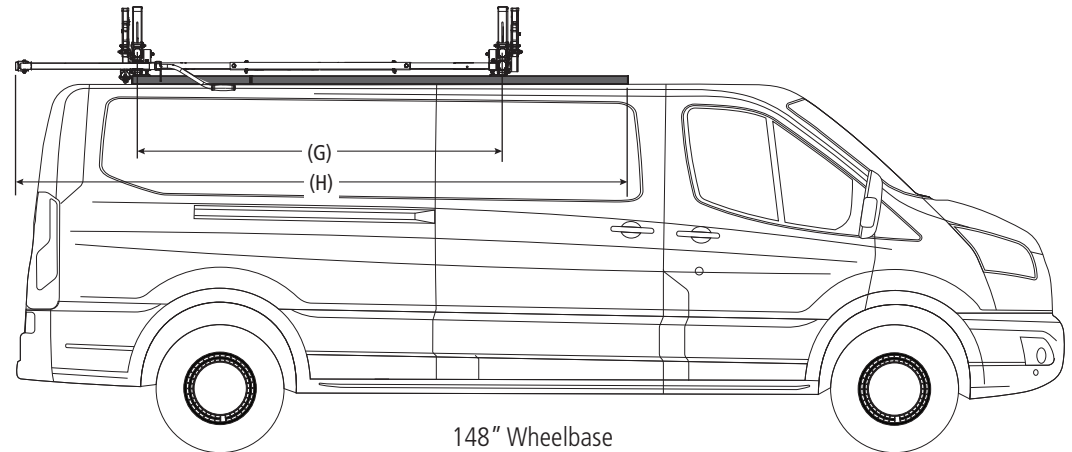

148" Wheelbase