

HRR3-E-NV-M

ErgoRack, Nissan NV

Three Crossbars, Powder Coat Finish
Rack Weight (empty): 164 lbs

*Callouts in this Configuration Overview indicate full module assemblies only.

For details on individual parts, please refer to the linked Module Overviews below.

- A: [FEA-0020 Rotation Driveshaft Assembly](#)
- B: [FBM-1010-BLK Mounting System](#)
- C: [CBR-0008 Mid Crossbar Kit](#)
- D: [FEA-0004 Slide Rotation Assembly](#)
- E: [CBR-0007 Crossbar Assembly](#)
- F: [FEA-0003 Slide Rotation Assembly](#)
- G: [FEA-0019 Rotation Driveshaft Assembly](#)

[Modular Assembly Manuals](#)

ErgoRack Van—Load specifications:

Check vehicle manufacturer recommendations for roof capacity weight limits.

CROSSBAR SPACING	STEP LADDER	EXT. LADDER
4 ft Spacing	6 – 8 ft.	16 – 20 ft.
5 ft Spacing	8 – 10 ft.	16 – 24 ft.
6 ft Spacing	8 – 12 ft. [†]	16 – 28 ft.
7 ft Spacing	10 – 12 ft. [†]	20 – 32 ft.
8 ft Spacing	10 – 12 ft. [†]	20 – 36 ft.

[†]Rotation Configurations: 12 ft. step ladders require an extended upper add-on component.

*Example shown with H1 (84" Roof Height) Configuration

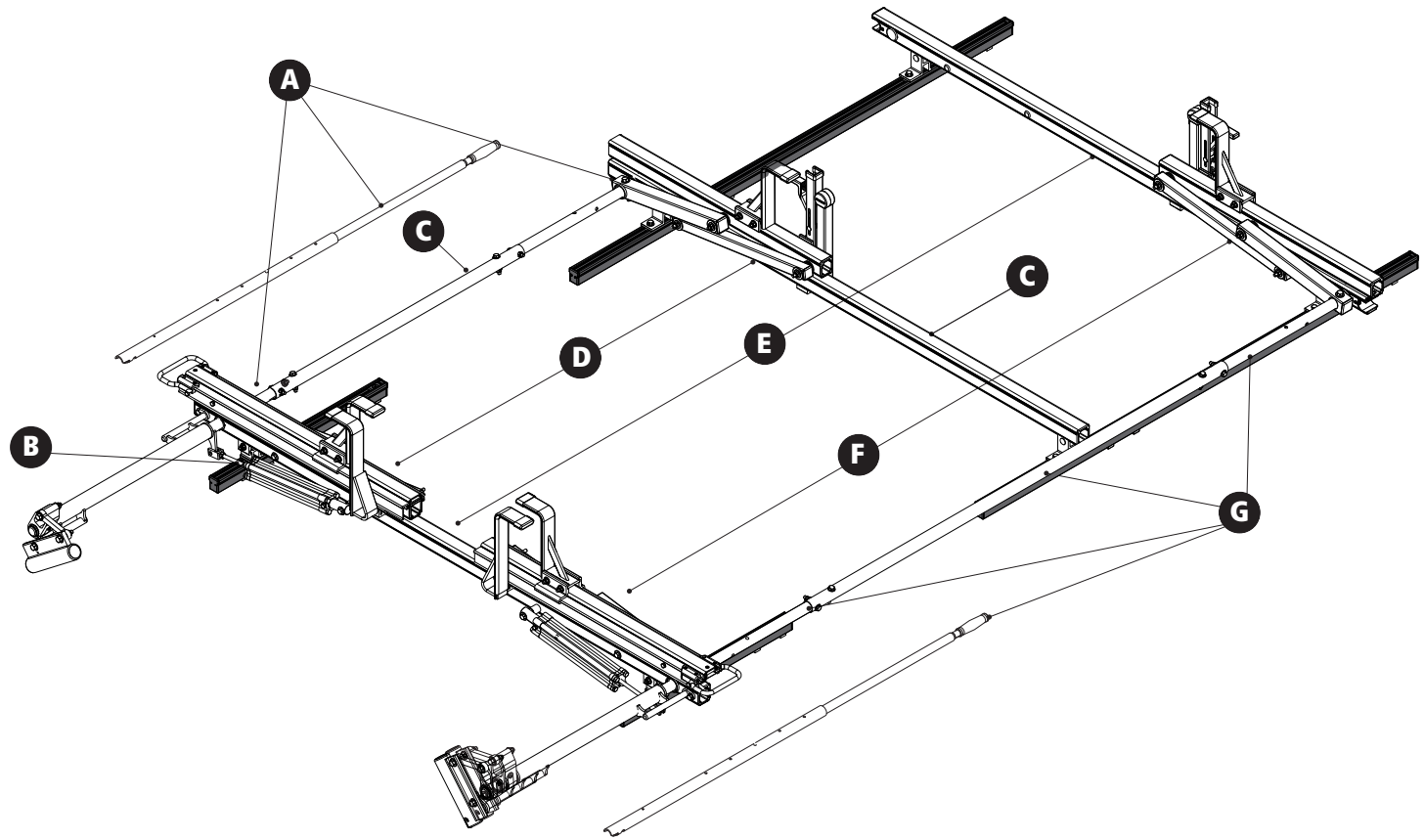

HRR3-E-NV-M

ErgoRack, Nissan NV

Approximate dimensions as shown:

All Heights

- A: Rack Width 79"
- B: Rack Height 16.50"
- C: Rear Crossbar Offset (L&R) Even
- D: Mount Spacing L/R Set at install

H1 (84")

- E: Crossbar Spacing (rear to center) 4'
- F: Crossbar Spacing (center to front) 2'-4'
- G: Total Crossbar Spacing 6'-8'
- H: Rack Length 108" - 132"

H2 (105")

- I: Crossbar Spacing (rear to center) 4'
- J: Crossbar Spacing (center to front) 2'-3'
- K: Total Crossbar Spacing 6'-7'
- L: Rack Length 105-117"

Compatible Accessories Available

(Sold Separately)

- Rear Access Ladder.....[AAL Series](#)
- 8'-12' Conduit Carriers.....[CON Series](#)
- WorkPro LED Lighting.....[LED Series](#)
- Systems and Safety Components[RVS Series](#)
- Safety monitoring.....[DS2 Series](#)

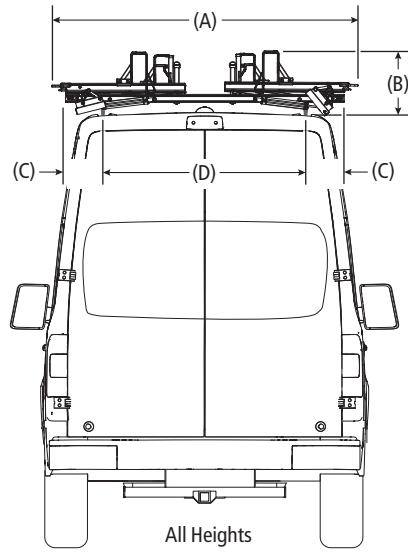

Rear Drive Shaft Offset: 29"

Note: The end of the driveshaft must not extend beyond the vehicle bumper

