

HRB-E-FT-M

ErgoRack, Ford Transit Mid/High Roof

Two Crossbars, Powder Coat Finish
Rack Weight (empty): 88 lbs

*Callouts in this Configuration Overview indicate full module assemblies only.

For details on individual parts, please refer to the linked Module Overviews below.

- A: [FEA-0001 End Stop Assembly](#)
- B: [FBM-1017-BLK Mounting System](#)
- C: [CBR-0007 Crossbar Assembly](#)
- D: [FEA-0004 Slide Rotation Assembly](#)
- E: [FEA-0020 Rotation Driveshaft Assembly](#)

[Modular Assembly Manuals](#)

ErgoRack Van—Load specifications:

Check vehicle manufacturer recommendations for roof capacity weight limits.

CROSSBAR SPACING	STEP LADDER	EXT. LADDER
4 ft Spacing	6 – 8 ft.	16 – 20 ft.
5 ft Spacing	8 – 10 ft.	16 – 24 ft.
6 ft Spacing	8 – 12 ft. [†]	16 – 28 ft.
7 ft Spacing	10 – 12 ft. [†]	20 – 32 ft.
8 ft Spacing	10 – 12 ft. [†]	20 – 36 ft.

[†]Rotation Configurations: 12 ft. step ladders require an extended upper add-on component.

*Example shown with 130" Wheelbase Configuration

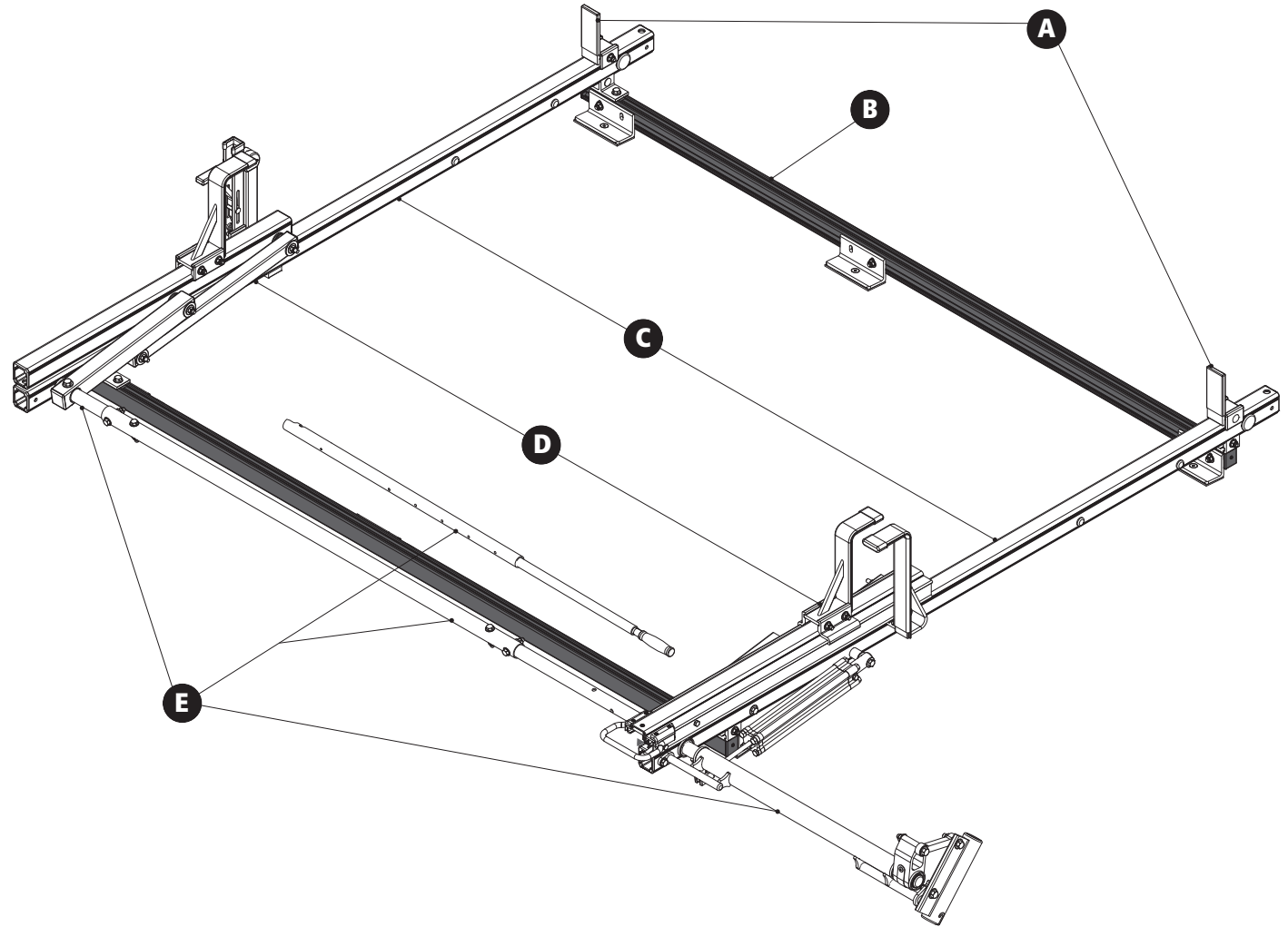

HRB-E-FT-M

ErgoRack, Ford Transit Mid Roof

Approximate dimensions as shown:

All Wheelbases

- A: Rack Width 76"
- B: Rack Height 16.50"
- C: Rear Crossbar Offset (Right) 8"
- D: Mount Bolt Spacing L/R 54"

130" Wheelbase

- E: Total Crossbar Spacing 6'
- F: Rack Length 105"

148" Wheelbase

- G: Total Crossbar Spacing 6'-8'
- H: Rack Length 129"

Compatible Accessories Available

(Sold Separately)

- Retractable Ratchet Tie-Down [ACC-8000](#)
- Rear Access Ladder [AAL Series](#)
- 8'-12' Conduit Carriers [CON Series](#)
- WorkPro LED Lighting [LED Series](#)
- Systems and Safety Components [RVS Series](#)
- Safety monitoring [DS2 Series](#)

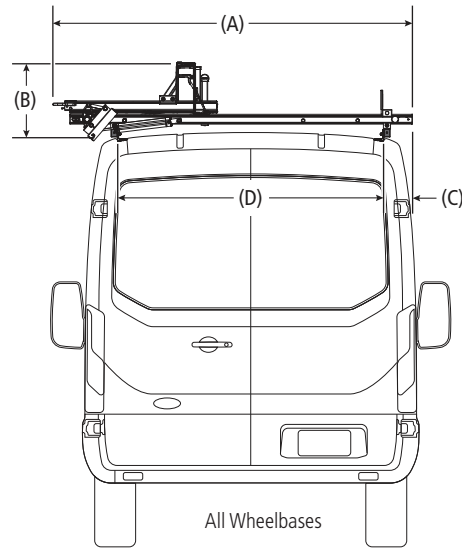

Rear Drive Shaft Offset: 29"

Note: The end of the driveshaft must not extend beyond the vehicle bumper

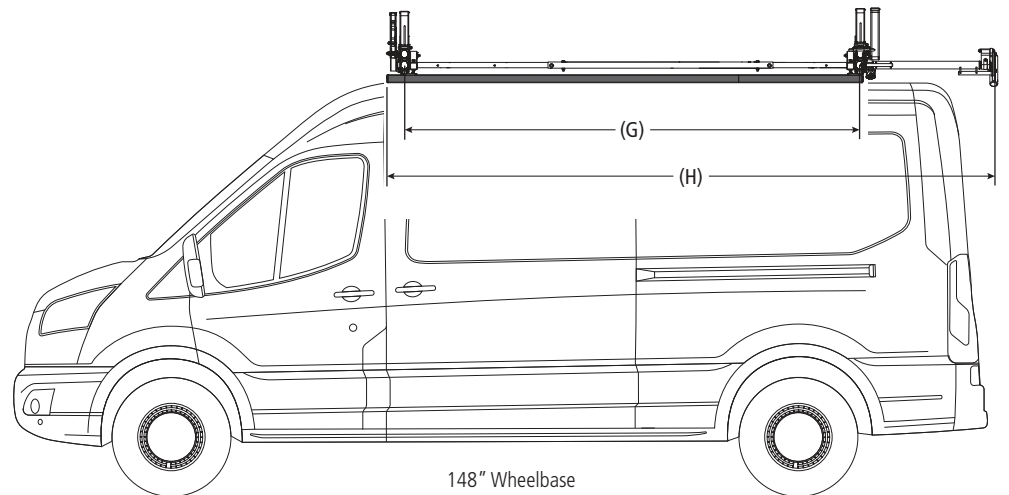
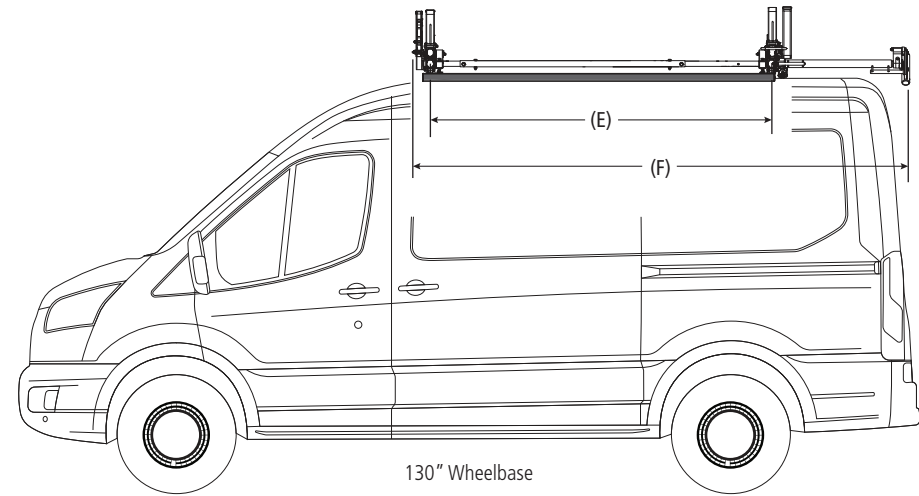
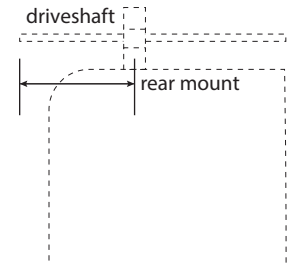

HRB-E-FT-M

ErgoRack, Ford Transit High Roof

Approximate dimensions as shown:

All Wheelbases

A: Rack Width	76"
B: Rack Height	16.50"
C: Rear Crossbar Offset (Right)	8"
D: Mount Bolt Spacing L/R.....	54"

130" Wheelbase

E: Total Crossbar Spacing.....	6'
F: Rack Length	105"

148" Wheelbase

G: Total Crossbar Spacing	6'–8'
H: Rack Length.....	129"

Compatible Accessories Available

(Sold Separately)

Retractable Ratchet Tie-Down.....	ACC-8000
Rear Access Ladder.....	AAL Series
8'–12' Conduit Carriers.....	CON Series
WorkPro LED Lighting.....	LED Series
Systems and Safety Components	RVS Series
Safety monitoring.....	DS2 Series

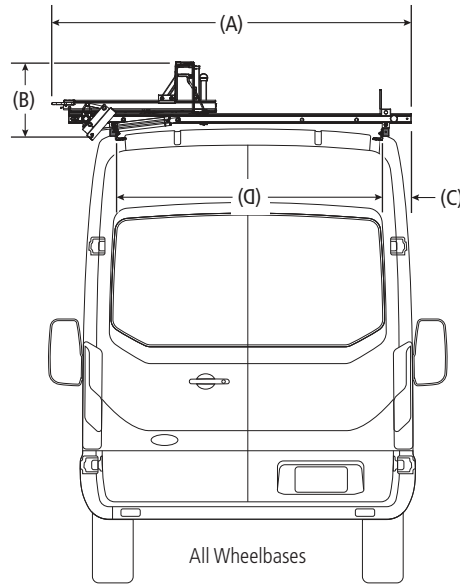

Rear Drive Shaft Offset: 29"

Note: The end of the driveshaft must not extend beyond the vehicle bumper

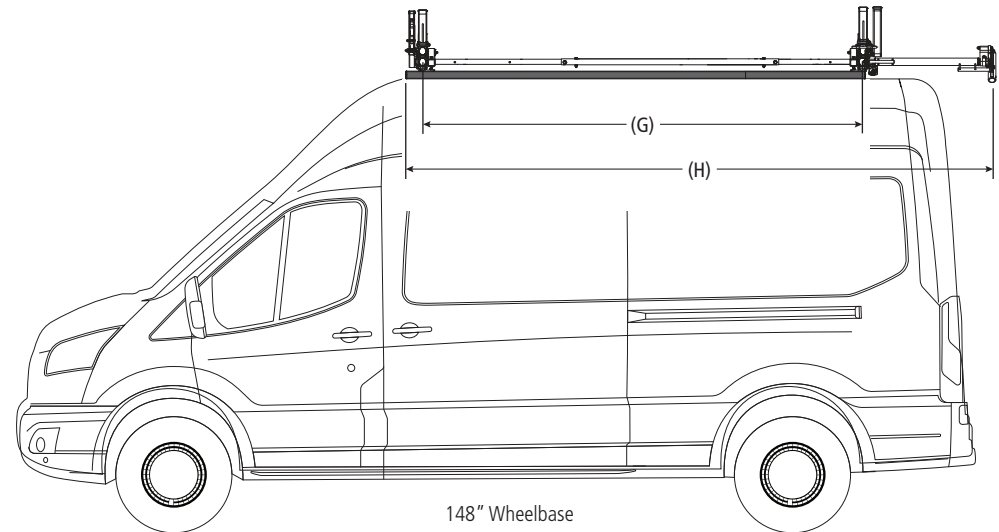
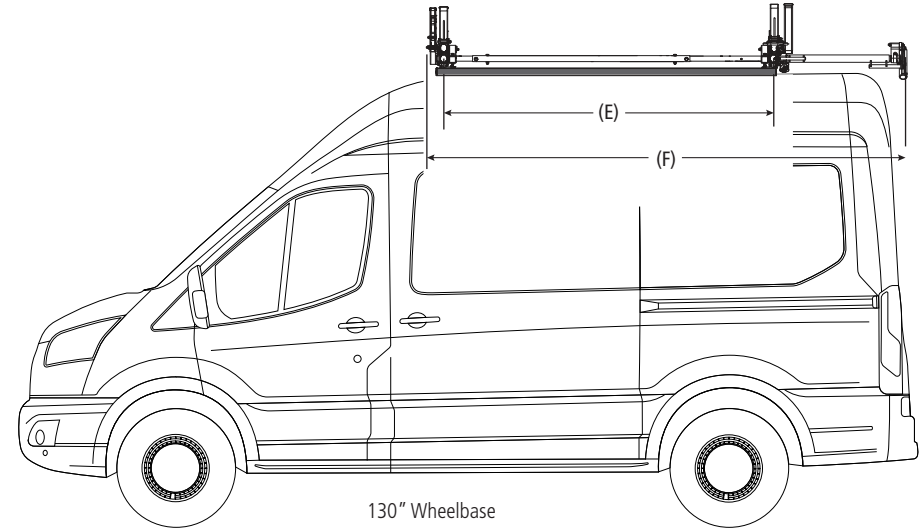
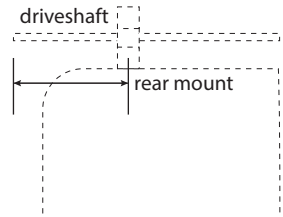

HRB-E-FT-M

ErgoRack, Ford Transit High Roof

Approximate dimensions as shown:

All Wheelbases

- A: Rack Width 76"
- B: Rack Height 16.50"
- C: Rear Crossbar Offset (Right) 8"
- D: Mount Bolt Spacing L/R..... 54"

148" Extended Wheelbase

- E: Total Crossbar Spacing..... 8'
- F: Rack Length 144"

Compatible Accessories Available

(Sold Separately)

- Retractable Ratchet Tie-Down [ACC-8000](#)
- Rear Access Ladder..... [AAL Series](#)
- 8'-12' Conduit Carriers..... [CON Series](#)
- WorkPro LED Lighting..... [LED Series](#)
- Systems and Safety Components [RVS Series](#)
- Safety monitoring..... [DS2 Series](#)

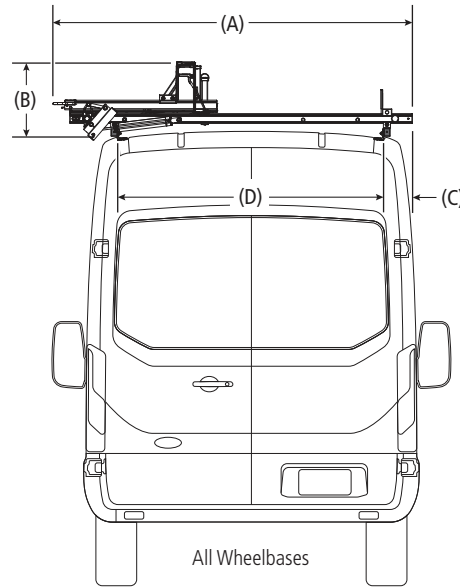

Rear Drive Shaft Offset: 29"

Note: The end of the driveshaft must not extend beyond the vehicle bumper

