

# PRIME DESIGN™

A Safe Fleet Brand

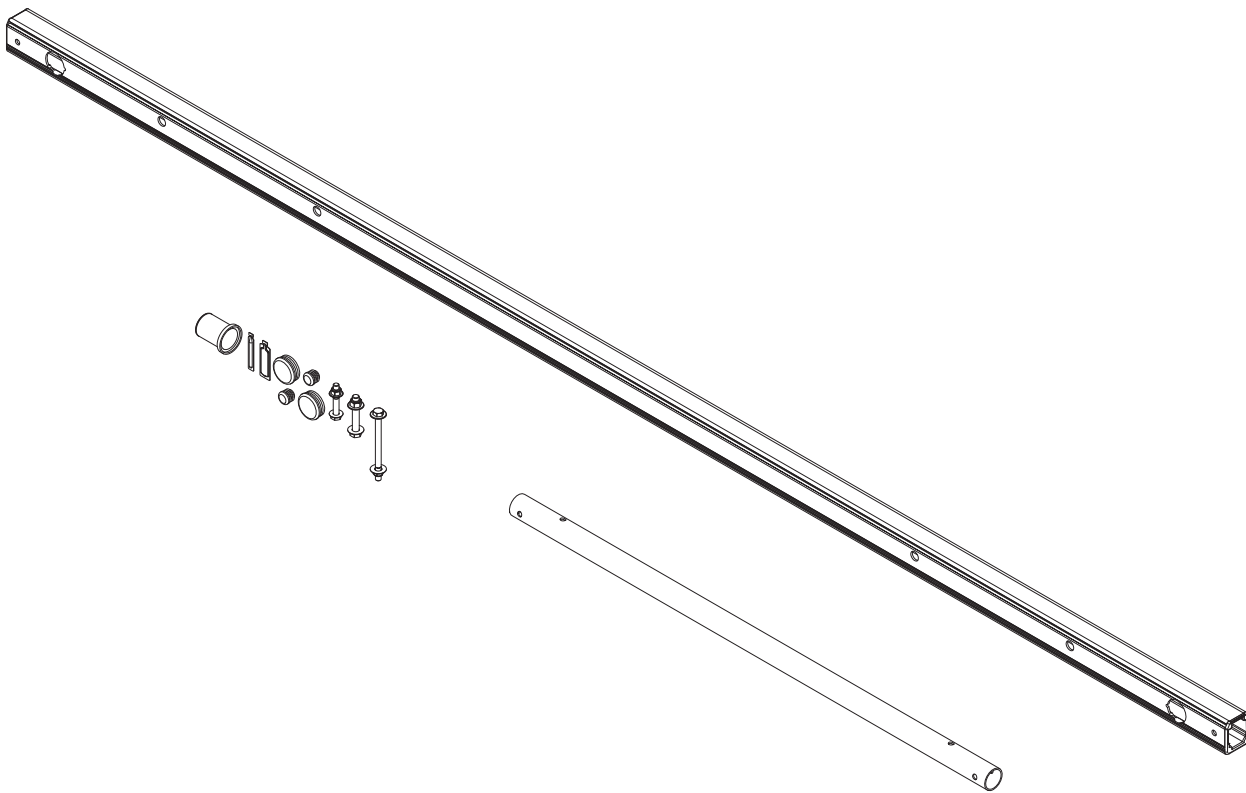

## *MID CROSSBAR KIT, 90"*

PRIME DESIGN, A SAFE FLEET BRAND • Address: 1689 Oakdale Avenue #102, West St Paul, Minnesota 55118  
Toll Free: 1.8.PRIME.RACK • Fax: 651-552-1799 • Email: [info@primedesign.net](mailto:info@primedesign.net) • Website: [www.primedesign.net](http://www.primedesign.net)

# CBR 0021

CONTENTS OVERVIEW



**Note:** This modular Crossbar kit can be installed as a retrofit conversion or new install.

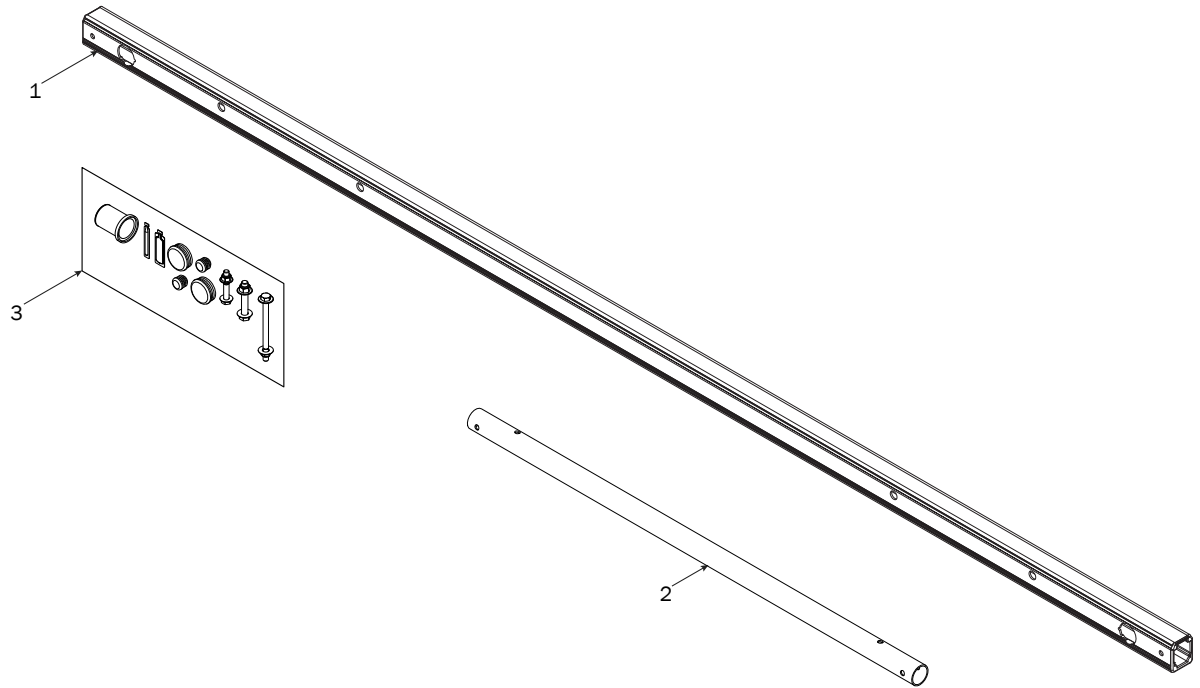

1—Crossbar..... (Qty 1)  
90.00"



2—Connecting Bar..... (Qty 1)  
36.00"



3—HKT-8407 ..... (Qty 1)  
Rotation Hardware Kit

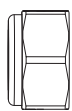
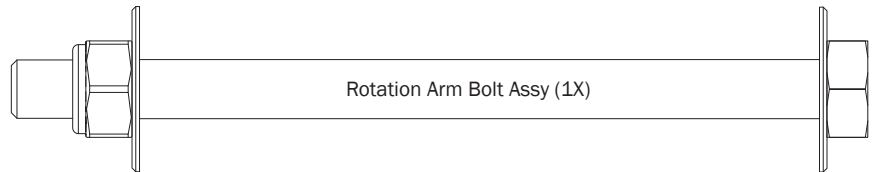

M8 Lock Nut (1X)



3/8" Lock Nut (1X)

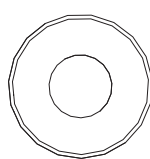

5/16" Flat Washer (2X)

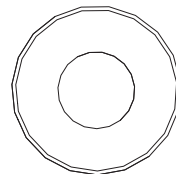

3/8" Flat Washer (2X)

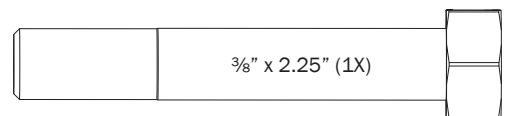

3/8" x 2.25" (1X)

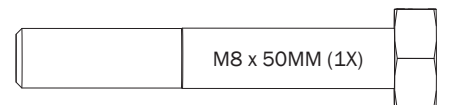

M8 x 50MM (1X)

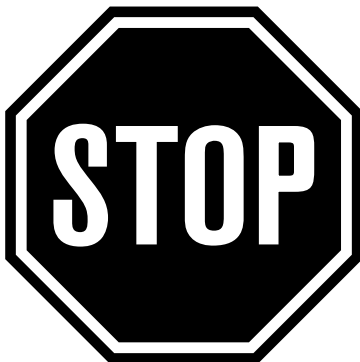
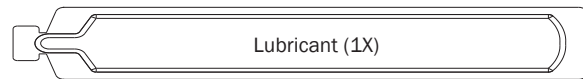
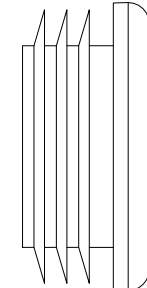
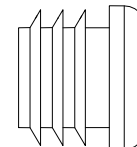
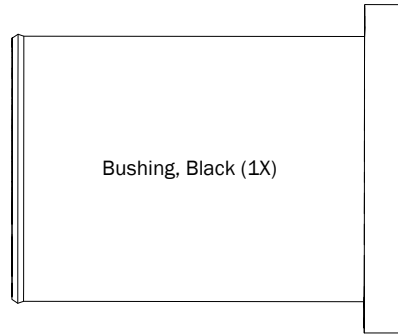
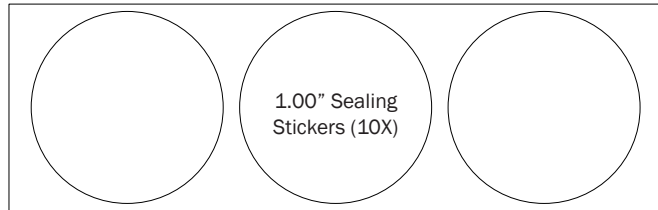

### FOR NEW INSTALLS: READ FIRST!

**Do not mount the Center Crossbar to an FBM system at this time.**

Refer to the respective FEA Assembly Manual(s) included with your chosen rack configuration features. Depending upon the features chosen, you may need to perform a complete feature assembly onto the Crossbars prior to mounting as noted in that feature's Assembly Manual.

*WARNING: Failure to position the Crossbars as shown in your FBM Assembly Manual may result in damage to the sliding and/or swinging doors, and/or ladder rack.*

**INSTALLER NOTE:** Base, Clamp Down, or Rotation features are not included in this CBR kit, and must be purchased separately. To purchase applicable features and accessories, please contact your authorized distributor, or a Prime Design Sales & Service Representative.

**MODIFICATION: 2 TO 3 CROSSBAR  
CONVERSION SEQUENCE**

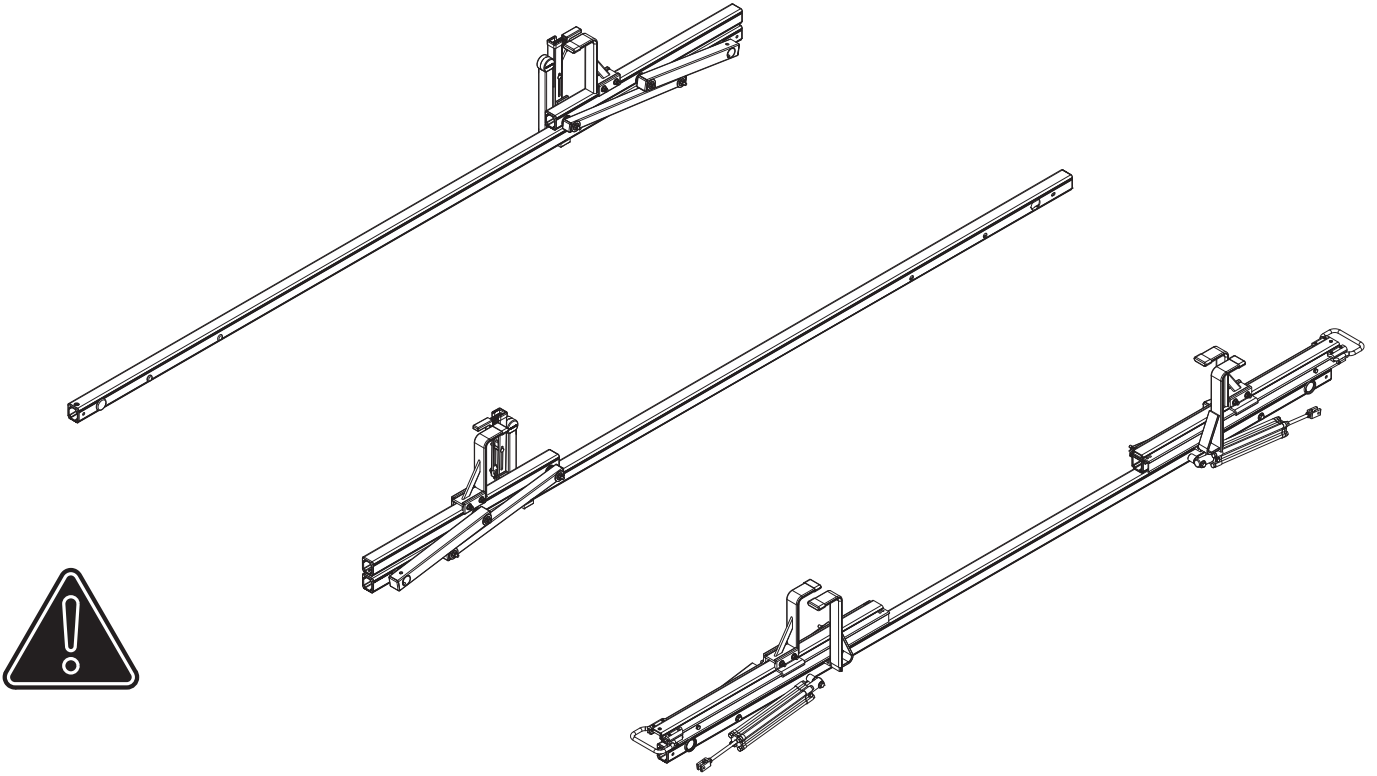

**SEQUENCE OVERVIEW**

NOTE: Crossbar conversions are most commonly performed on the street side. If you require the conversion on the curb side, all instructions remain the same.

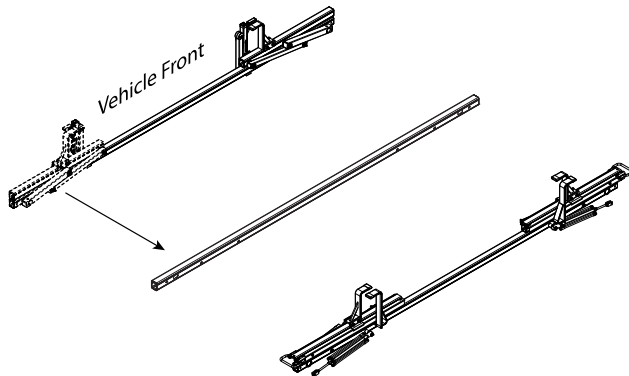

**UNINSTALLING FRONT ROTATION**

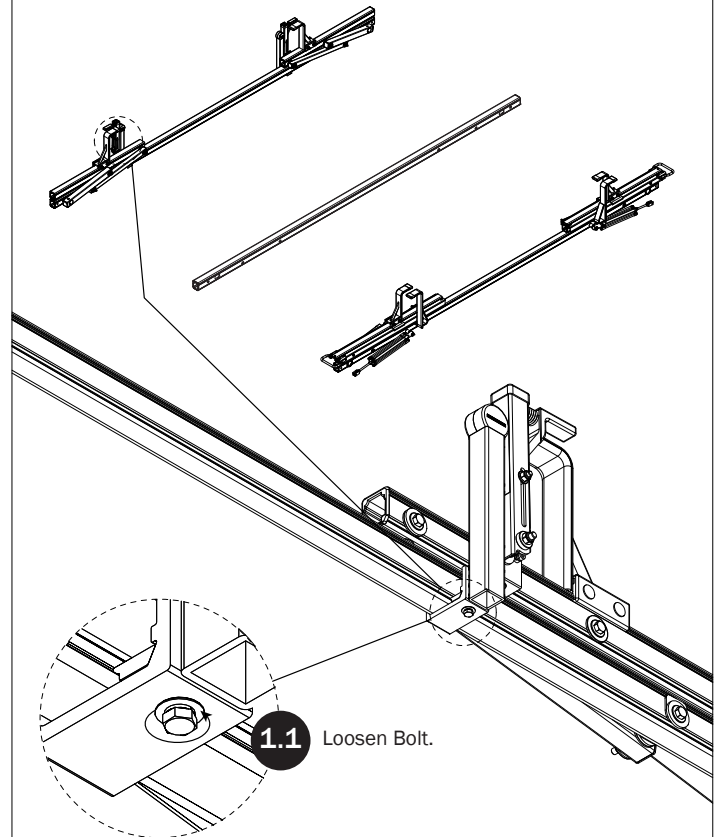

**1.2** Remove and save the L-Post.

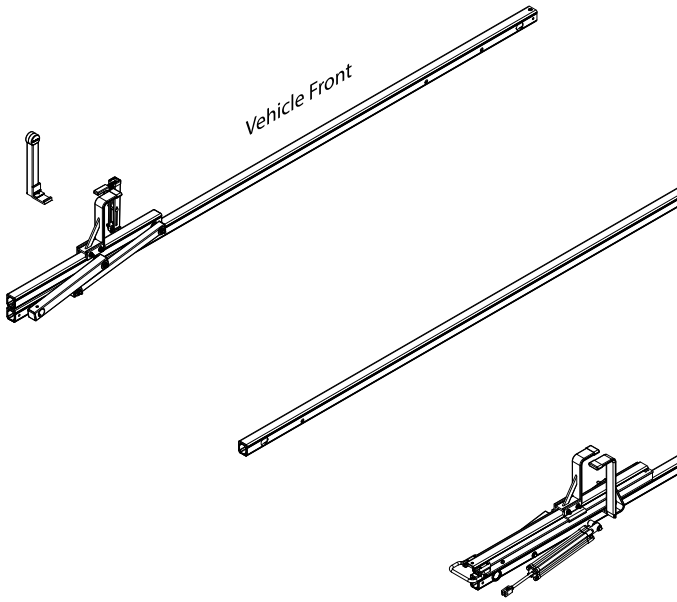

**1.3** Open the Rotation as shown.

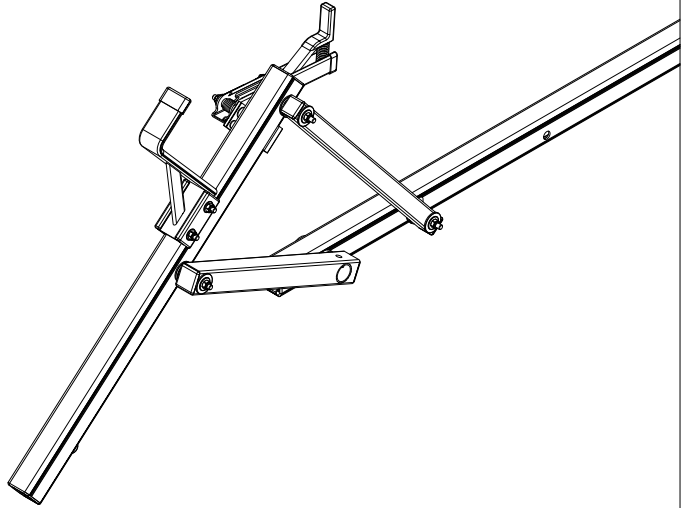

**1.4** Remove and save front Rotation and Hardware as shown.

NOTE: The front Bushing, if damaged, may be replaced with the Bushing contained in this Assembly's Hardware Kit.

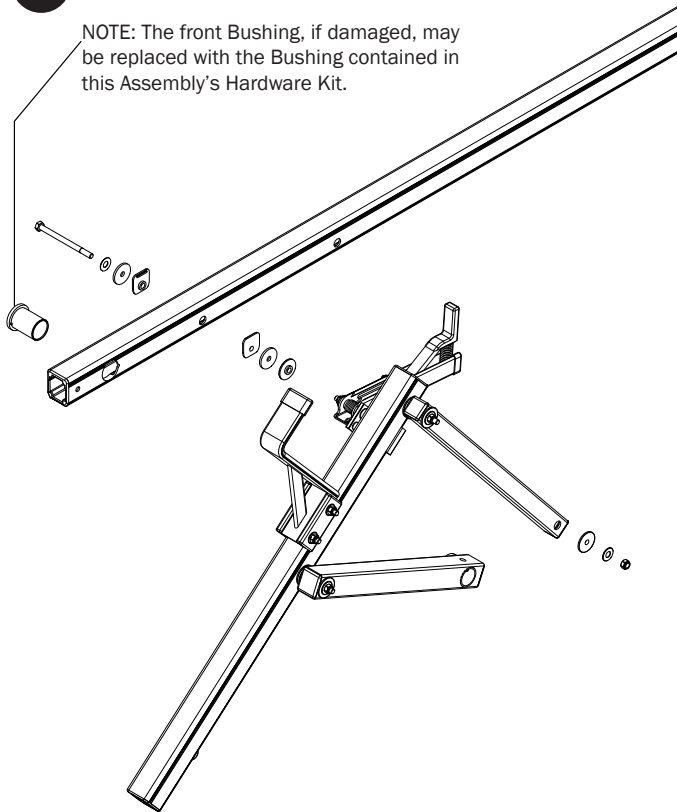

### **INSTALLING MID ROTATION** SEE QUICK START GUIDE FOR ADJUSTMENTS

**2.1** Install the Rotation and Hardware onto the Mid Crossbar as shown.

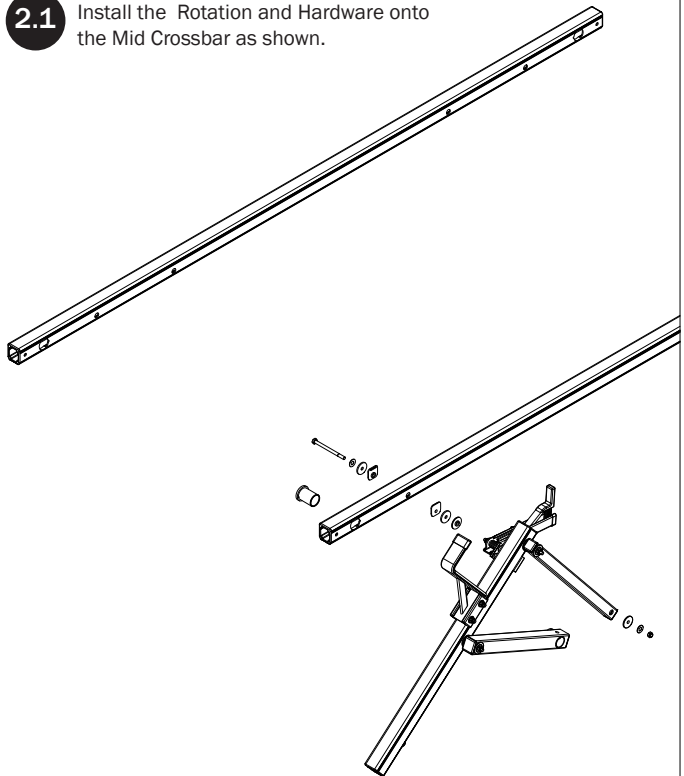

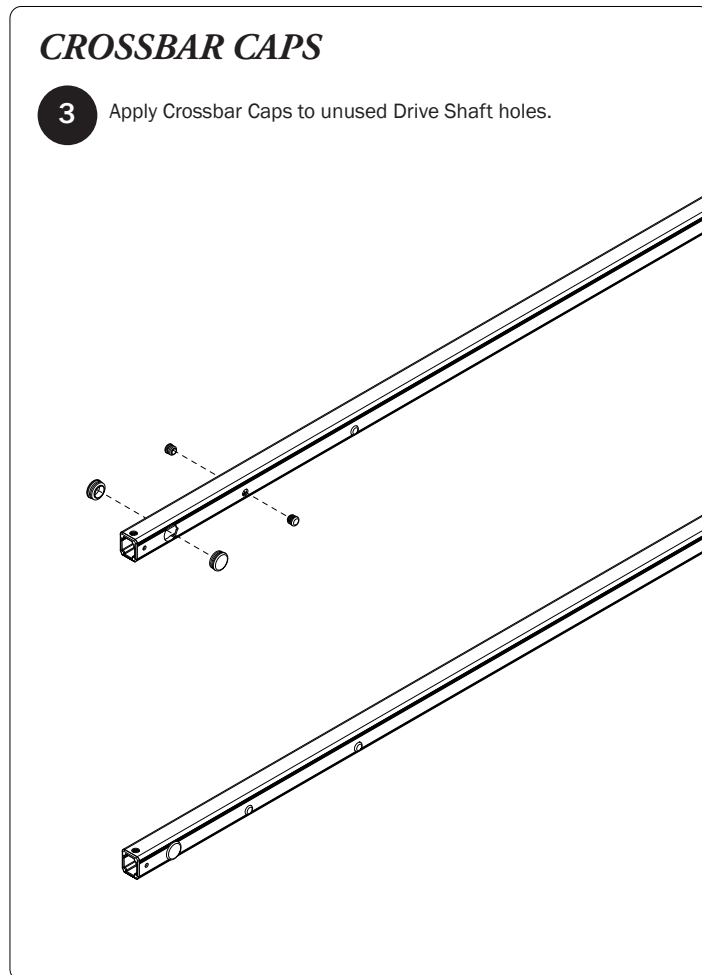
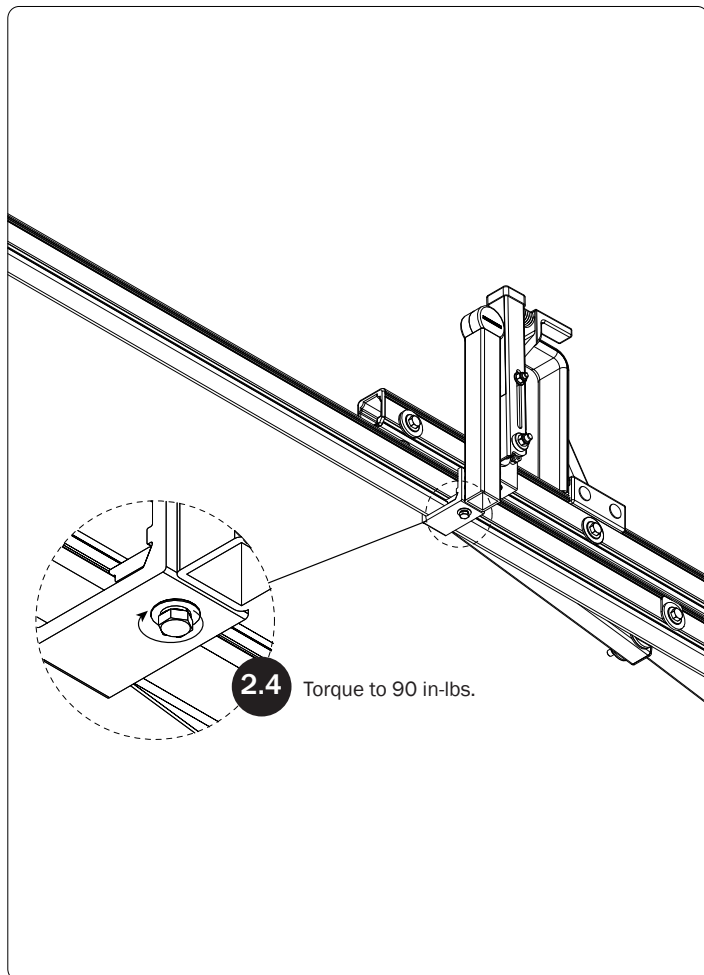
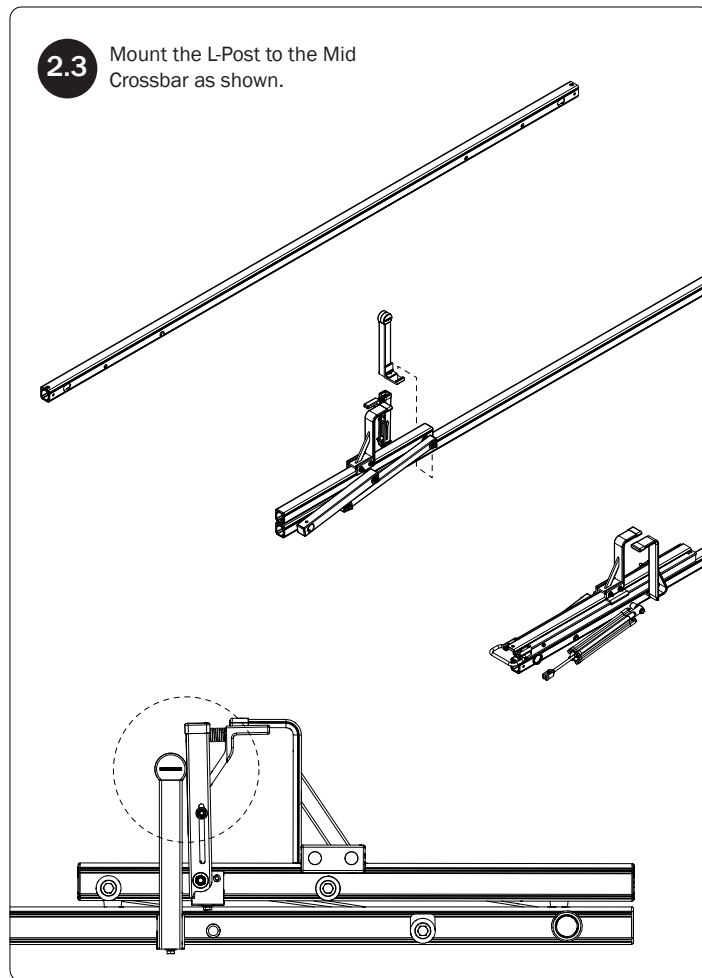
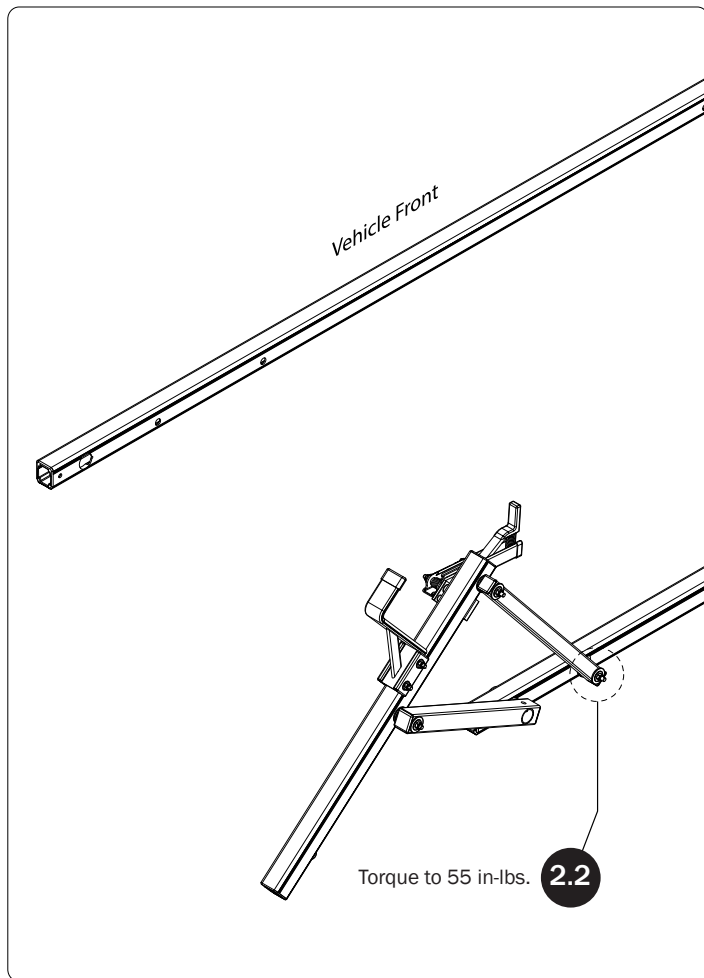

Page Intentionally Left Blank

