

PRIME DESIGN™

A Safe Fleet Brand

AR1907

AluRack Pickup, 8' TAG

Configuration as shown:

Anodized Aluminum
Rack Weight (empty): 38 lbs

*Callouts in this Configuration Overview indicate full module assemblies only.

For details on individual parts, please refer to the linked Module Overviews below.

A: [AR-2103 112" Side Rail Feature](#)

B: [AR-2000 53" Crossbar Feature](#)

[Modular Assembly Manuals](#)

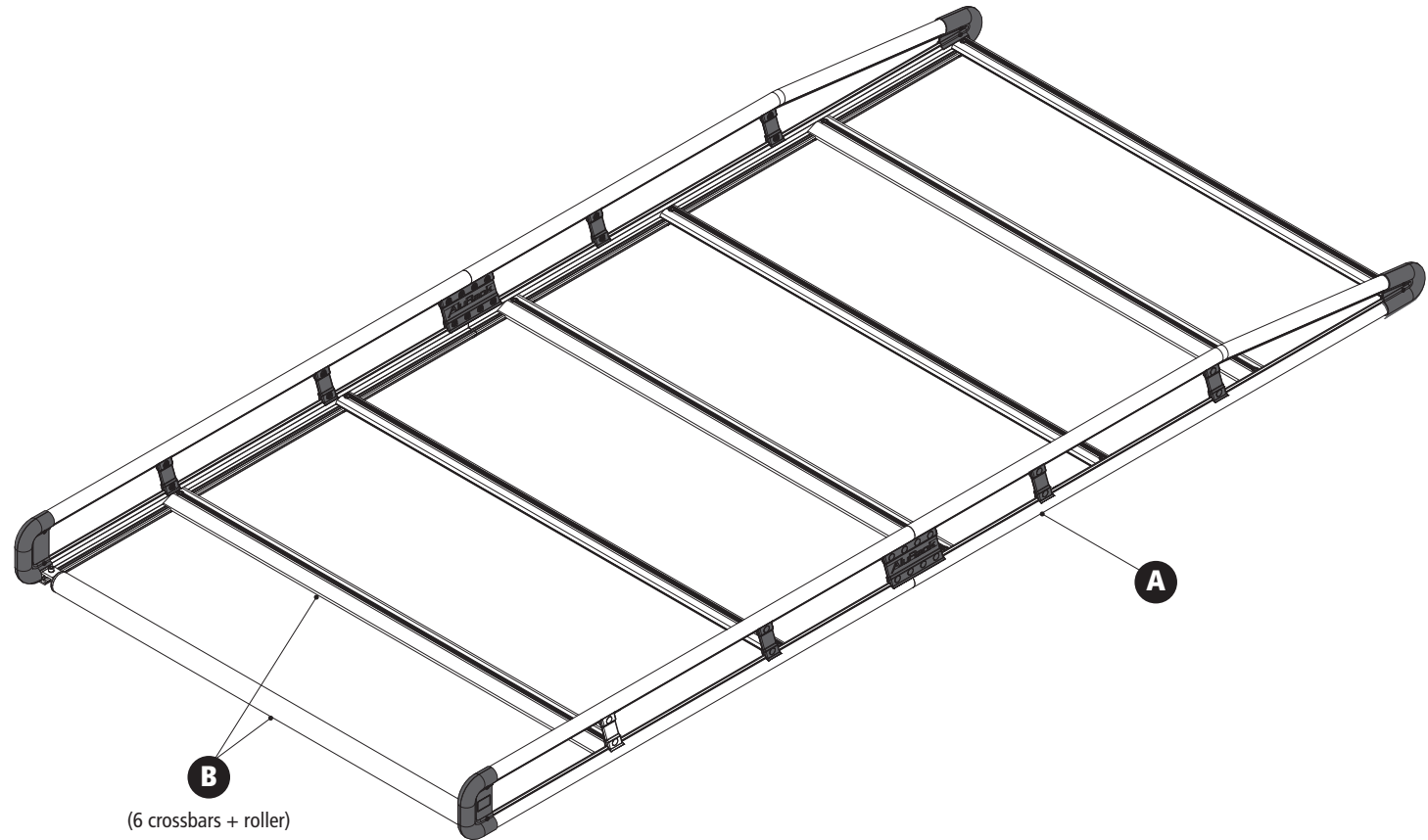

AluRack—Load specifications:

Check vehicle manufacturer recommendations for roof capacity weight limits.

AR1907

Pickup, 8' TAG

Approximate dimensions as shown:

- A: Rack Width 55"
- B: Rack Length 116"
- C: Rack Height 7.50"

Compatible Accessories Available (Sold Separately)

- Ladder Clamp Down..... [ACX-AXC Series](#)
- Retractable Ratchet Tie-Down.....[ACC-8000](#)
- 8'–12' Conduit Tubes[CON Series](#)
- WorkPro LED Lighting..... [LED Series](#)
- Systems and Safety Components[RVS Series](#)
- Safety monitoring.....[DS2 Series](#)
- Rear Access Ladder.....[AAL Series](#)

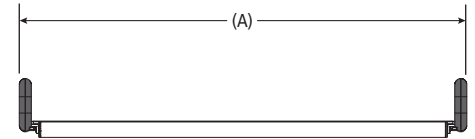
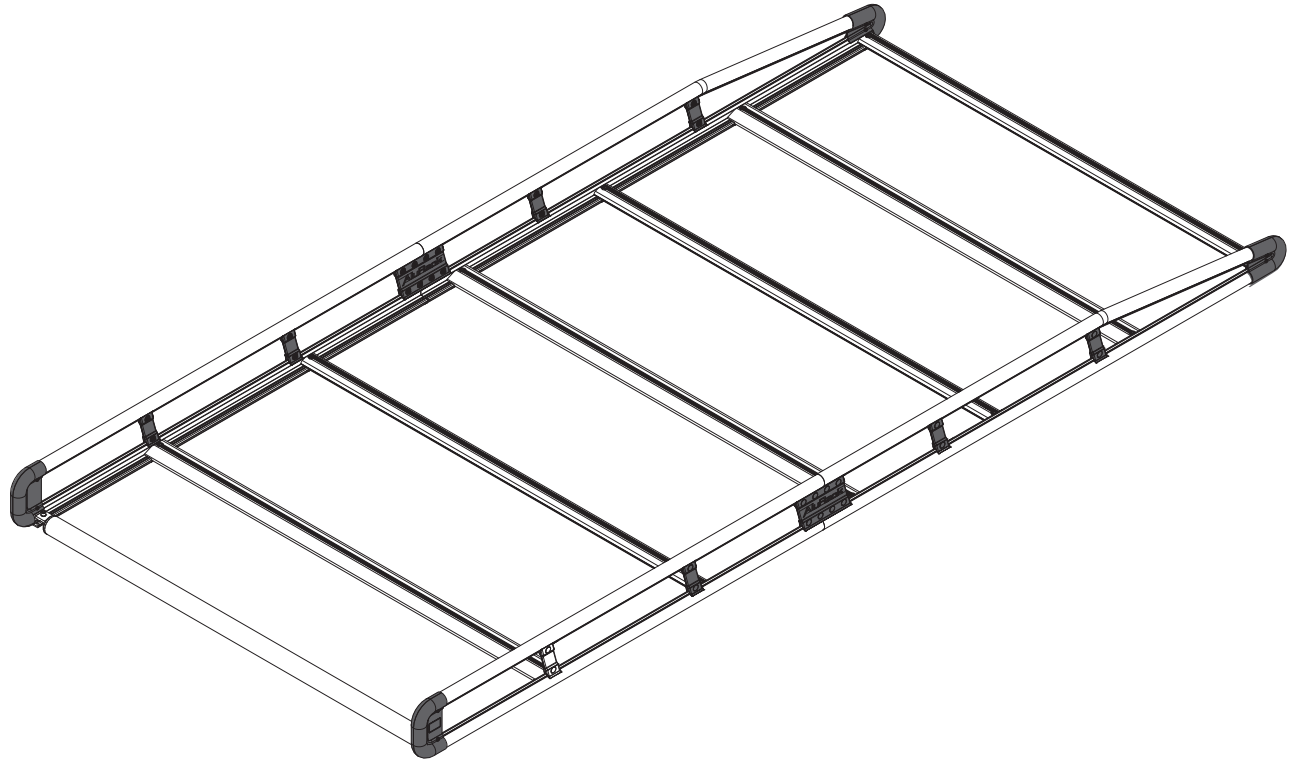

Mounting width is set according to vehicle specifications

