

PRIME DESIGN™

A Safe Fleet Brand

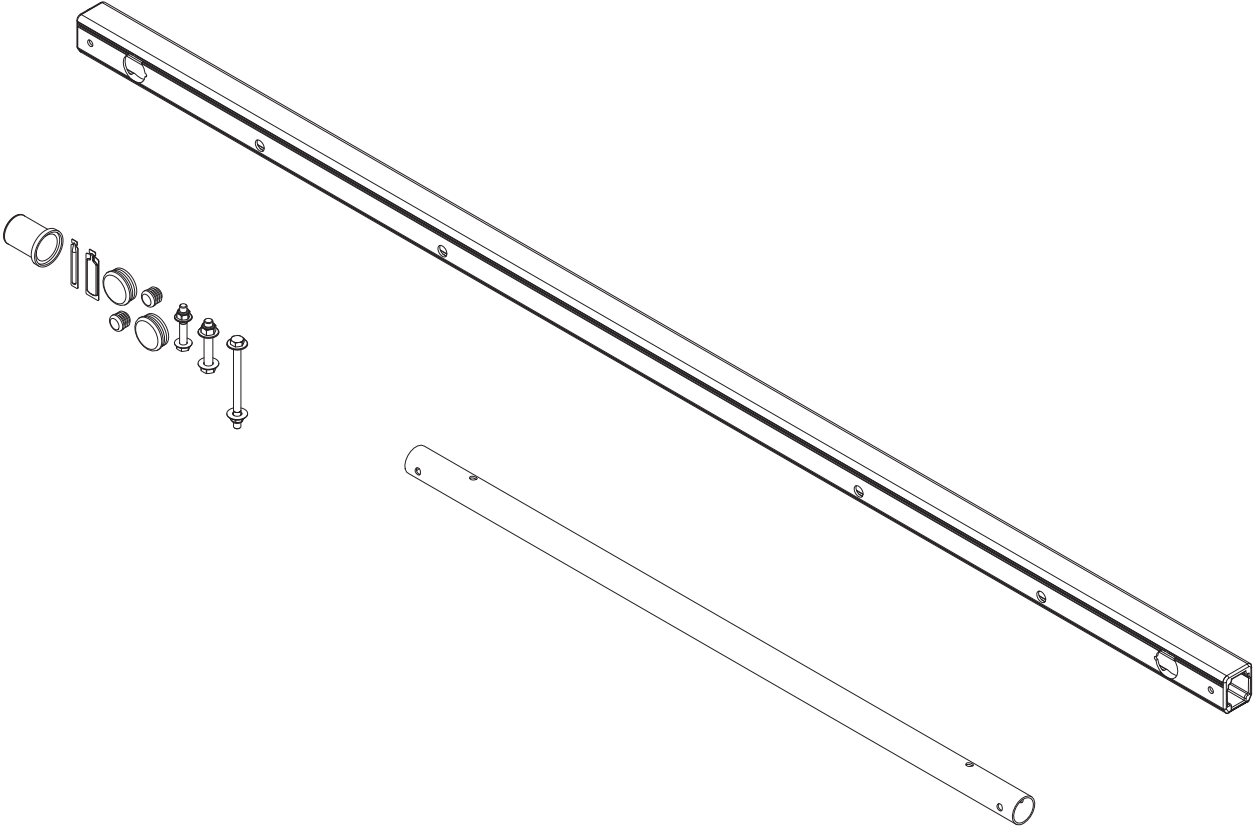

MID CROSSBAR KIT, 72"

PRIME DESIGN, A SAFE FLEET BRAND • Address: 1689 Oakdale Avenue #102, West St Paul, Minnesota 55118
Toll Free: 1.8.PRIME.RACK • Fax: 651-552-1799 • Email: info@primedesign.net • Website: www.primedesign.net



CONTENTS OVERVIEW



Note: This modular Crossbar kit can be installed as a retrofit conversion or new install.

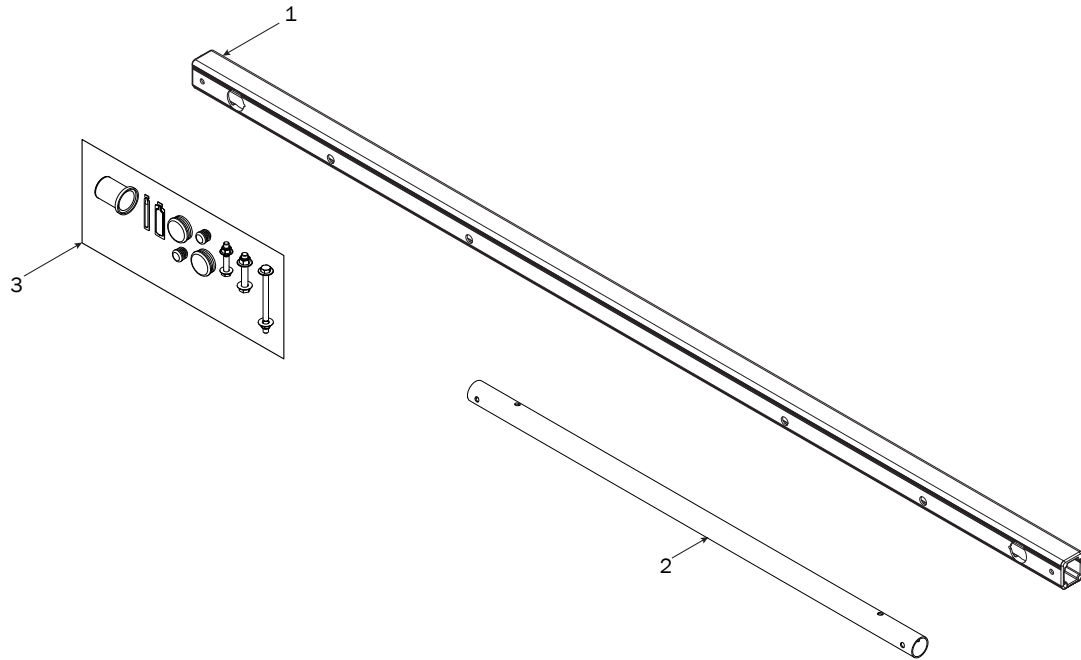

1—Crossbar..... (Qty 1)
72.00"



2—Connecting Bar..... (Qty 1)
36.00"



3—HKT-8407 (Qty 1)
Rotation Hardware Kit

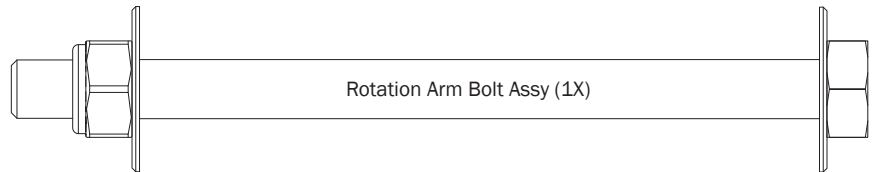

Rotation Arm Bolt Assy (1X)

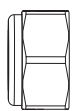

M8 Lock Nut (1X)



3/8" Lock Nut (1X)

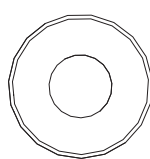

5/16" Flat Washer (2X)

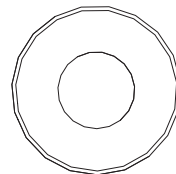

3/8" Flat Washer (2X)

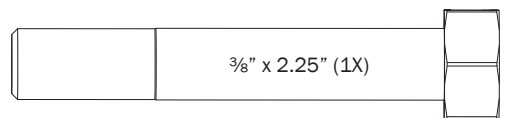

3/8" x 2.25" (1X)

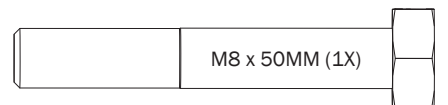

M8 x 50MM (1X)

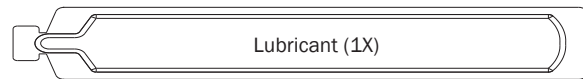
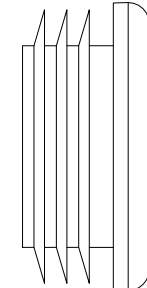
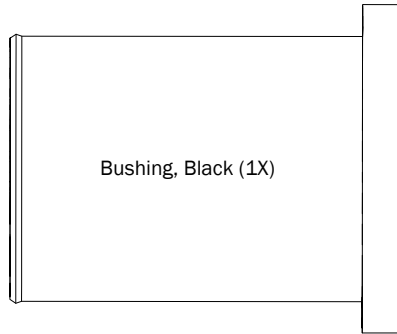
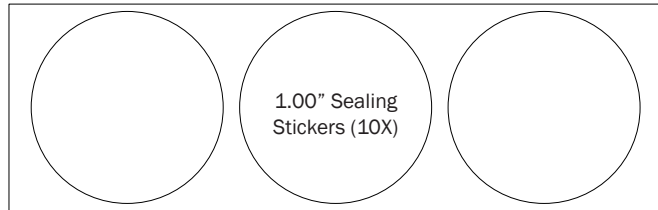

FOR NEW INSTALLS: READ FIRST!

Do not mount the Center Crossbar to an FBM system at this time.

Refer to the respective FEA Assembly Manual(s) included with your chosen rack configuration features. Depending upon the features chosen, you may need to perform a complete feature assembly onto the Crossbars prior to mounting as noted in that feature's Assembly Manual.

WARNING: Failure to position the Crossbars as shown in your FBM Assembly Manual may result in damage to the sliding and/or swinging doors, and/or ladder rack.

INSTALLER NOTE: Base, Clamp Down, or Rotation features are not included in this CBR kit, and must be purchased separately. To purchase applicable features and accessories, please contact your authorized distributor, or a Prime Design Sales & Service Representative.

**MODIFICATION: 2 TO 3 CROSSBAR
CONVERSION SEQUENCE**

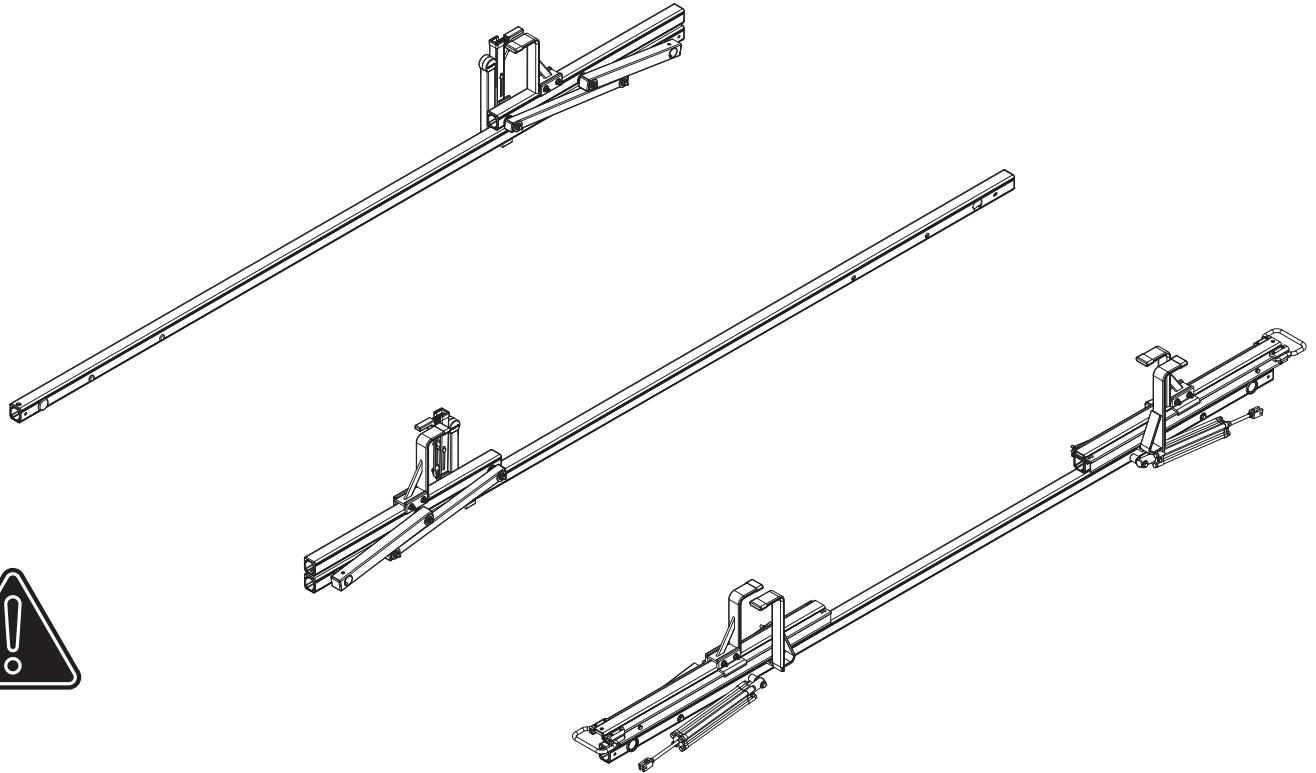

SEQUENCE OVERVIEW

NOTE: Crossbar conversions are most commonly performed on the street side. If you require the conversion on the curb side, all instructions remain the same.

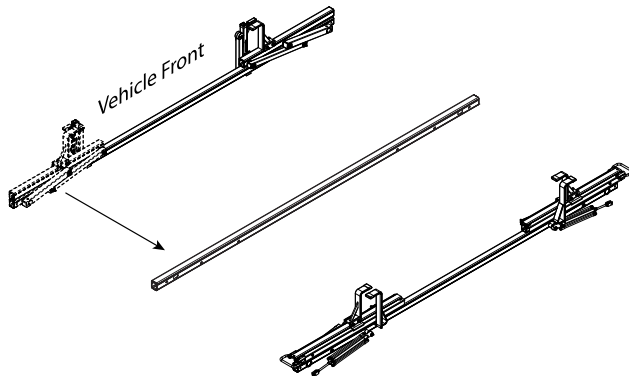

UNINSTALLING FRONT ROTATION

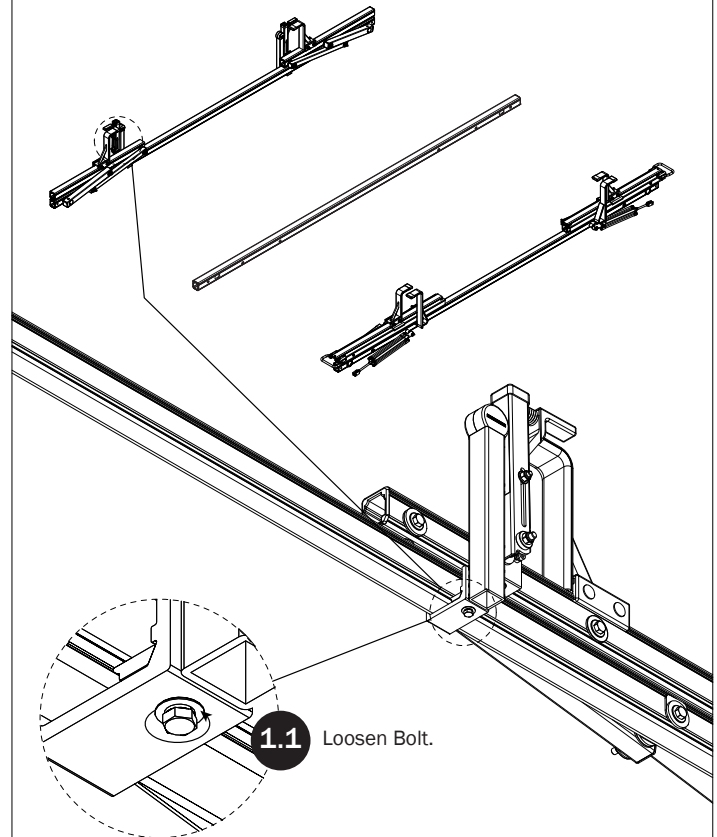

1.2 Remove and save the L-Post.

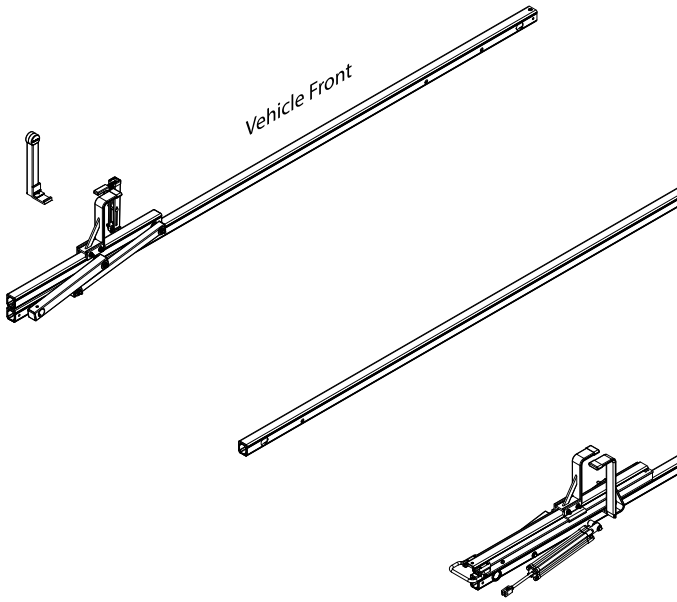

1.3 Open the Rotation as shown.

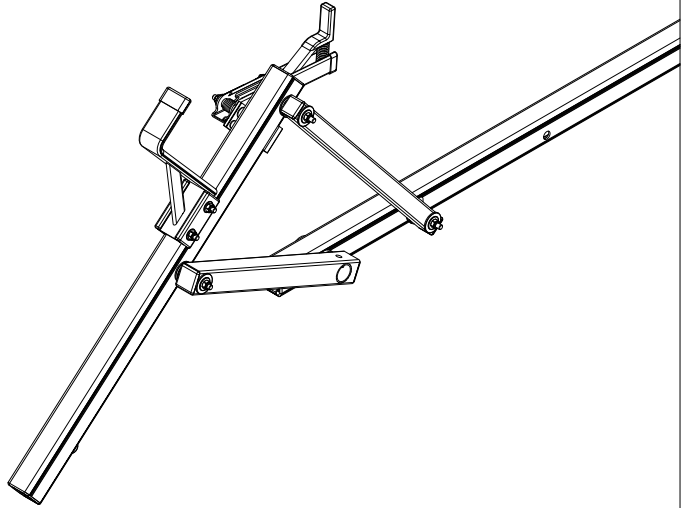

1.4 Remove and save front Rotation and Hardware as shown.

NOTE: The front Bushing, if damaged, may be replaced with the Bushing contained in this Assembly's Hardware Kit.

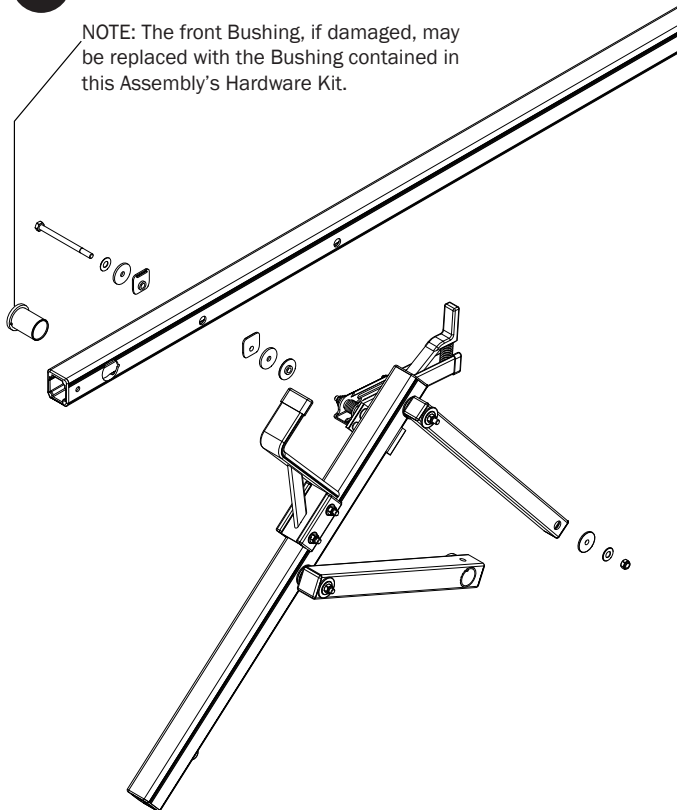

INSTALLING MID ROTATION SEE QUICK START GUIDE FOR ADJUSTMENTS

2.1 Install the Rotation and Hardware onto the Mid Crossbar as shown.

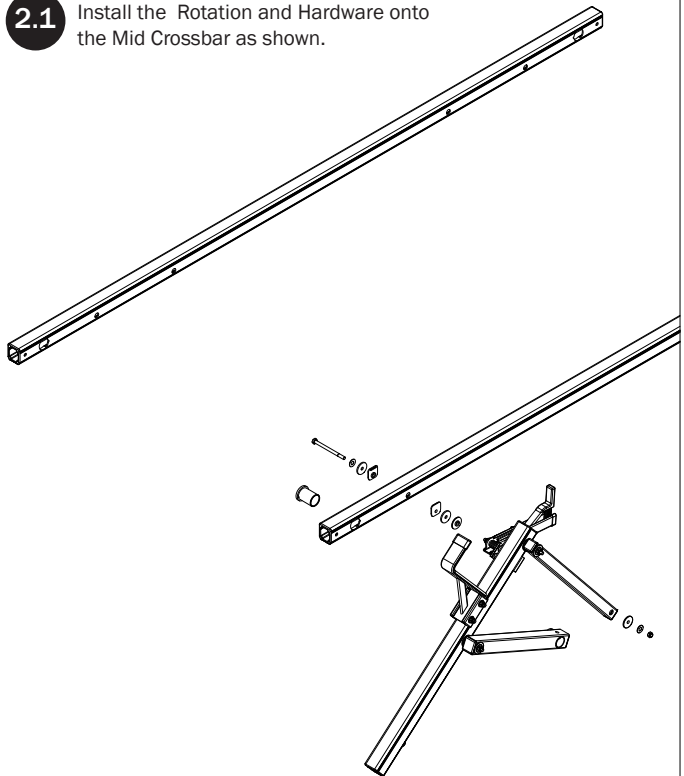

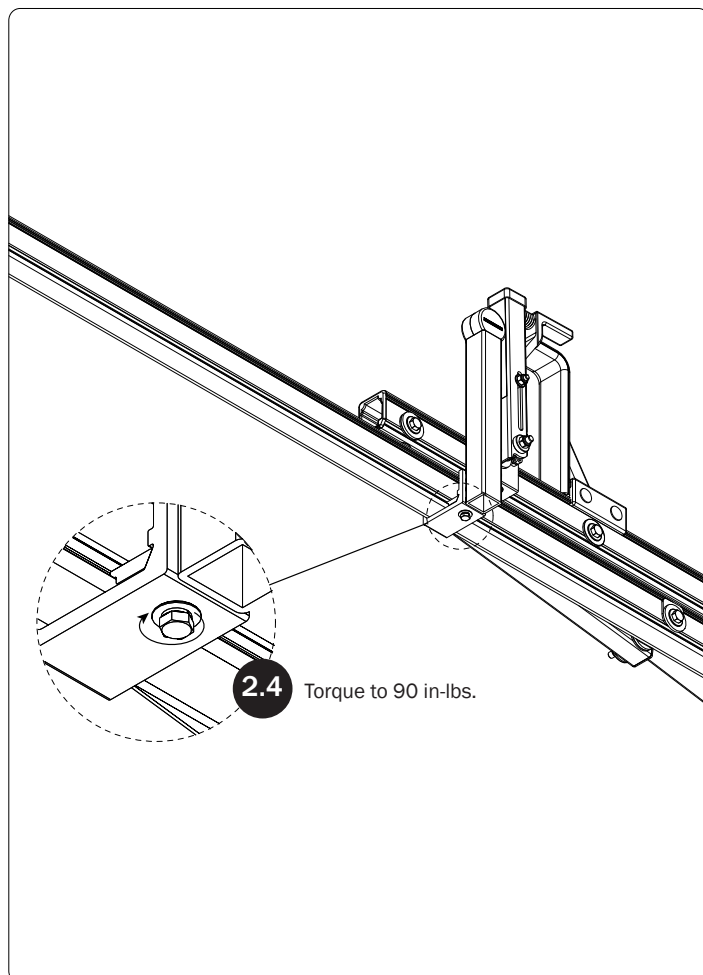
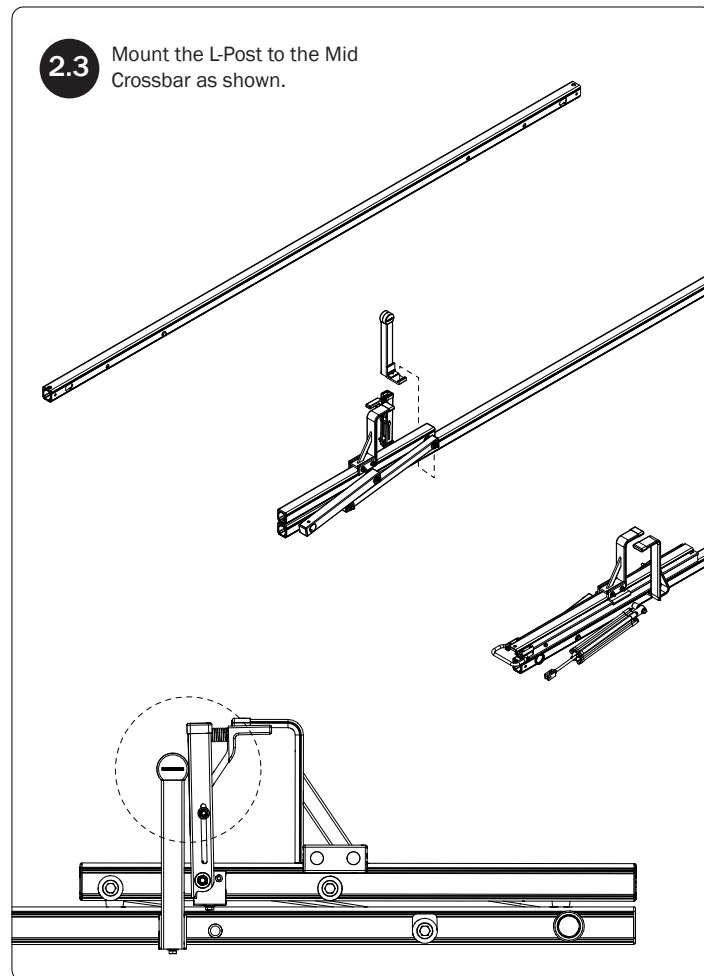
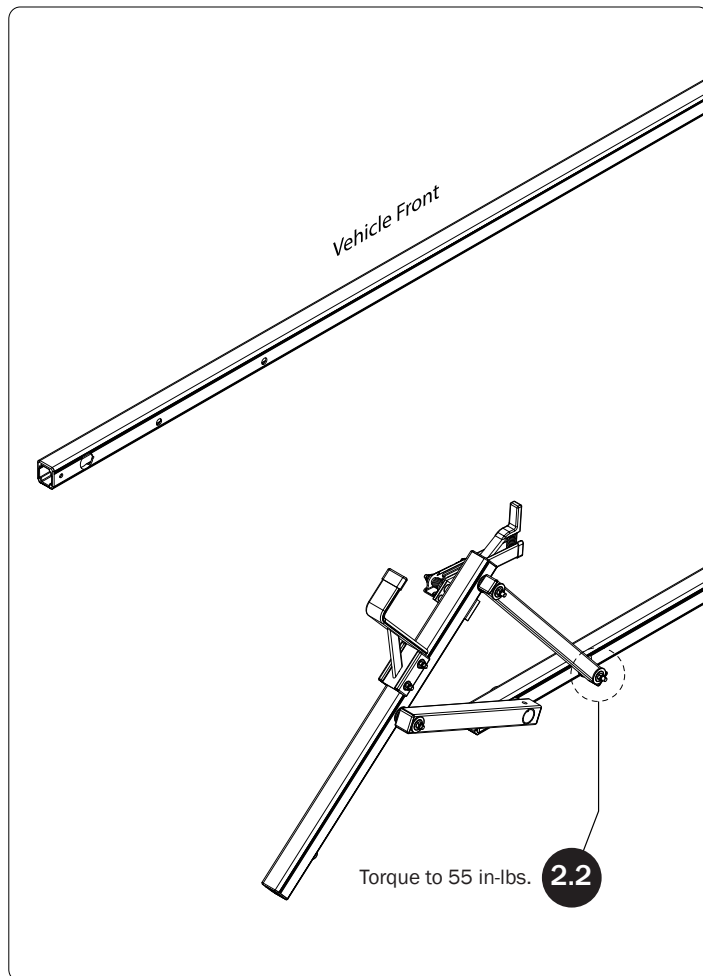

CROSSBAR CAPS

- 3** Apply Crossbar Caps to unused Drive Shaft holes.

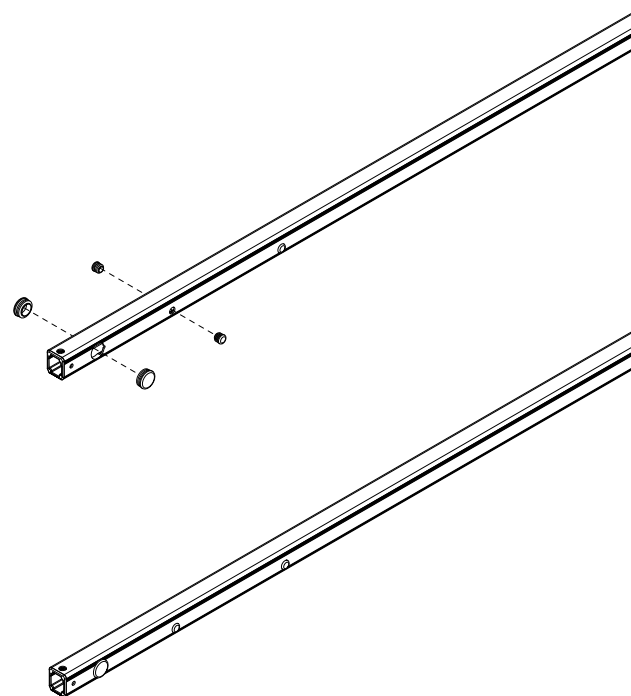

Page Intentionally Left Blank

