

HRR3-E-SP-HM

ErgoRack, Sprinter

Three Crossbars, Powder Coat Finish
Rack Weight (empty): 167 lbs

*Callouts in this Configuration Overview indicate full module assemblies only.

For details on individual parts, please refer to the linked Module Overviews below.

- A: [FBM-1008-BLK Mounting System](#)
- B: [CBA-3008 Hybrid Crossbar Assembly](#)
- C: [CBR-0008 Mid Crossbar Kit](#)
- D: [FEA-0019 Rotation Driveshaft Assembly](#)
- E: [FEA-0020 Rotation Driveshaft Assembly](#)

[Modular Assembly Manuals](#)

ErgoRack Van—Load specifications:

Check vehicle manufacturer recommendations for roof capacity weight limits.

| CROSSBAR SPACING | STEP LADDER | EXT. LADDER |
|------------------|--------------------------|-------------|
| 4 ft Spacing | 6 – 8 ft. | 16 – 20 ft. |
| 5 ft Spacing | 8 – 10 ft. | 16 – 24 ft. |
| 6 ft Spacing | 8 – 12 ft. [†] | 16 – 28 ft. |
| 7 ft Spacing | 10 – 12 ft. [†] | 20 – 32 ft. |
| 8 ft Spacing | 10 – 12 ft. [†] | 20 – 36 ft. |

[†]Rotation Configurations: 12 ft. step ladders require an extended upper add-on component.

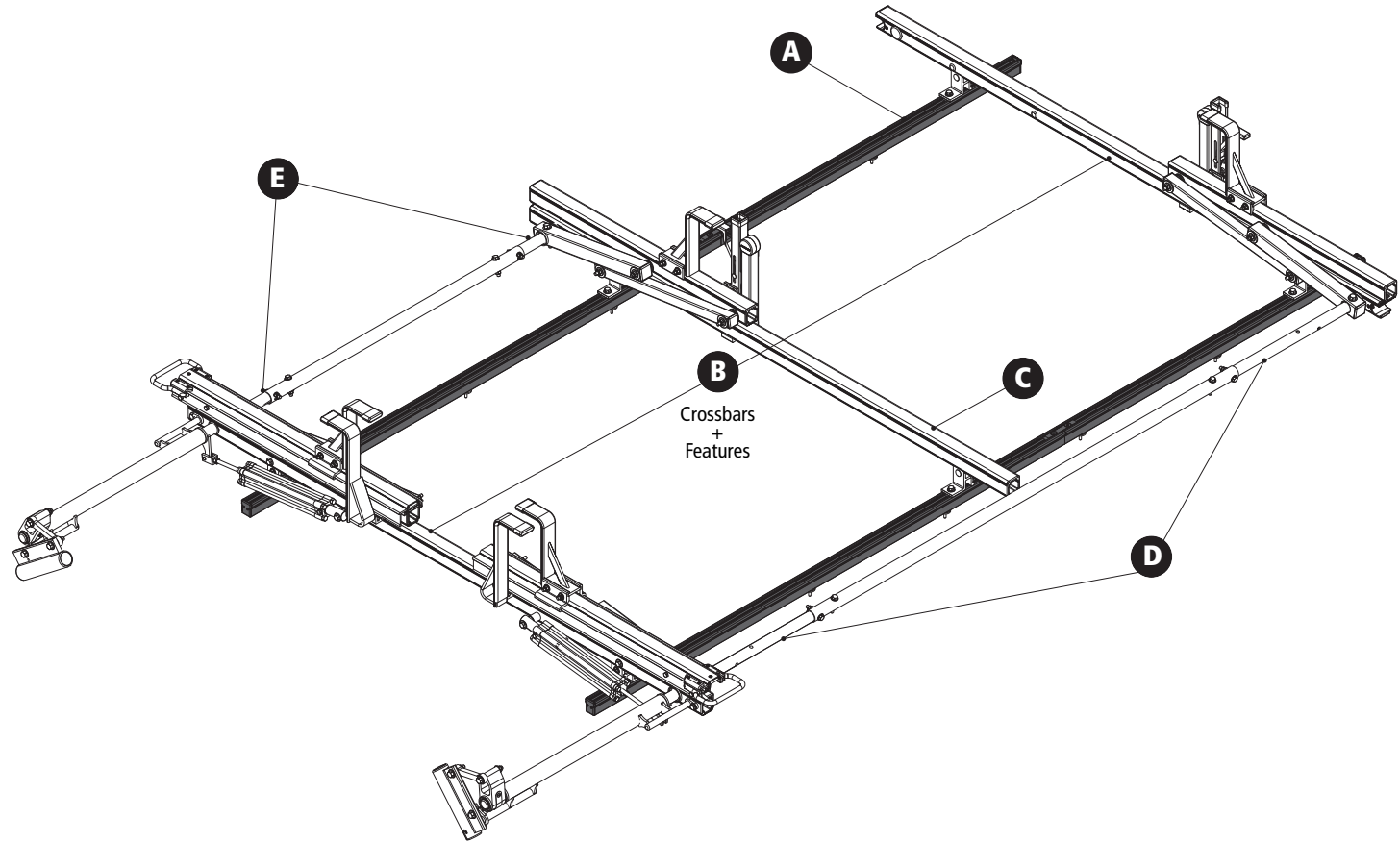

HRR3-E-SP-HM

ErgoRack, Sprinter

*Approximate dimensions as shown:
Shown installed on a Sprinter L1H2*

All Wheelbases and Roof Heights

- A: Rack Width 79"
- B: Rack Height 16.50"
- C: Rear Crossbar Offset (Left)..... 10.125"
- D: Mount Spacing L/R..... 52"
- E: Crossbar Spacing (rear to center) 4'
- F: Crossbar Spacing (center to front) 2'-4'
- G: Total Crossbar Spacing 6'-8'
- H: Rack Length 131.50"

Compatible Accessories Available

(Sold Separately)

- Rear Access Ladder.....[AAL Series](#)
- 8'-12' Conduit Carriers.....[CON Series](#)
- WorkPro LED Lighting.....[LED Series](#)
- Systems and Safety Components[RVS Series](#)
- Safety monitoring.....[DS2 Series](#)

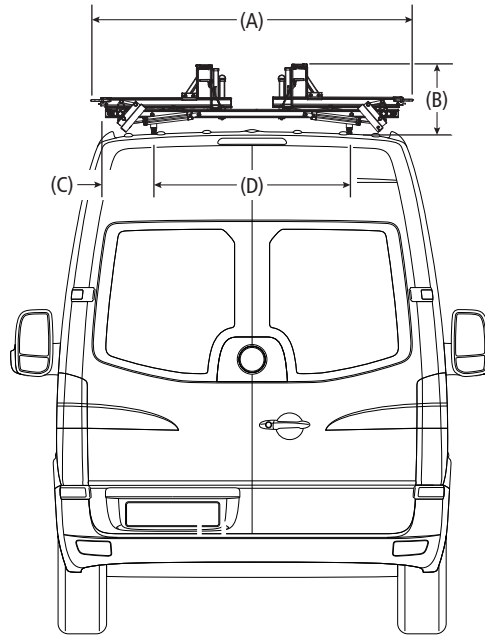

Rear Drive Shaft Offset: 29"

Note: The end of the driveshaft must not extend beyond the vehicle bumper

