

## VRR3-GM-HM

### ErgoRack, GM Van

Three Crossbars, Powder Coat Finish  
Rack Weight (empty): 141 lbs

\*Callouts in this Configuration Overview indicate full module assemblies only.

For details on individual parts, please refer to the linked Module Overviews below.

- B:..... [FBM-1025-BLK Mounting System](#)
- B:..... [CBA-3006 Hybrid Crossbar Assembly](#)
- C:..... [CBR-0004 Mid Crossbar Assembly](#)
- D:..... [FEA-0022 Rotation Feature \(x1\)](#)
- E:..... [FEA-0015 Rotation Driveshaft Feature](#)
- F:..... [FEA-0016 Rotation Driveshaft Feature](#)

[Modular Assembly Manuals](#)

### ErgoRack Van—Load specifications:

Check vehicle manufacturer recommendations for roof capacity weight limits.

CROSSBAR SPACING	STEP LADDER	EXT. LADDER
4 ft Spacing	6 – 8 ft.	16 – 20 ft.
5 ft Spacing	8 – 10 ft.	16 – 24 ft.
6 ft Spacing	8 – 12 ft. <sup>†</sup>	16 – 28 ft.
7 ft Spacing	10 – 12 ft. <sup>†</sup>	20 – 32 ft.
8 ft Spacing	10 – 12 ft. <sup>†</sup>	20 – 36 ft.

<sup>†</sup>Rotation Configurations: 12 ft. step ladders require an extended upper add-on component.

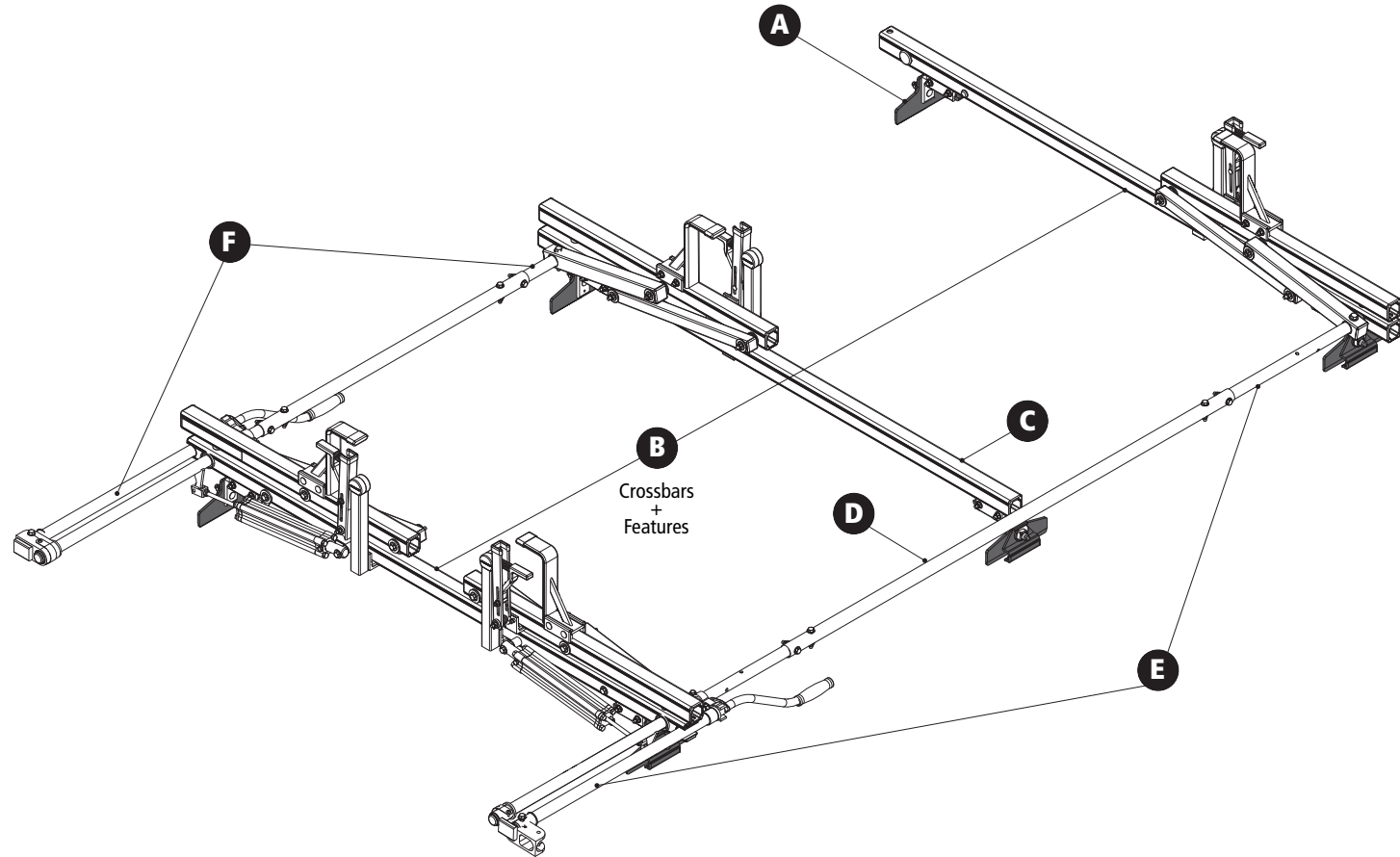

## VRR3-GM-HM

### ErgoRack, GM Van

Approximate dimensions as shown:

- A: Rack Width ..... 68"
- B: Rack Height ..... 16"
- C: Rear Crossbar Offset (Left)..... 17.25"
- D: Mount Bolt Spacing L/R..... Variable
- E: Crossbar Spacing (rear to center) ..... 4'
- F: Crossbar Spacing (center to front) ..... 2'-4'
- G: Total Crossbar Spacing..... 6'-8'
- H: Rack Length..... 98" – 122"

#### Compatible Accessories Available

(Sold Separately)

- Rear Access Ladder..... [AAL Series](#)
- 8'-12' Conduit Carriers..... [CON Series](#)
- WorkPro LED Lighting..... [LED Series](#)
- Systems and Safety Components ..... [RVS Series](#)
- Safety monitoring..... [DS2 Series](#)

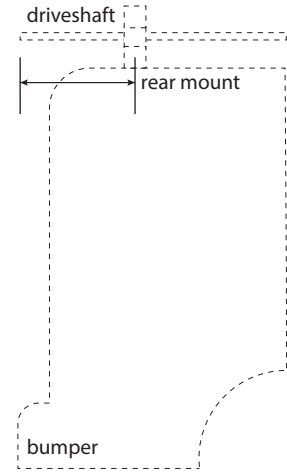
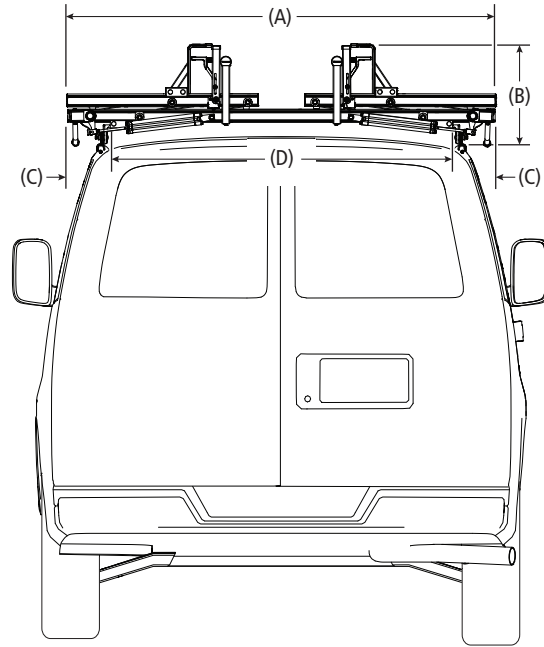

Rear Drive Shaft Offset: 24"

Note: The end of the driveshaft must not extend beyond the vehicle bumper

