

PRIME DESIGN™

A Safe Fleet Brand

CSU-3003

Cantilever Shelf Upright 24" Shelving

Approximate dimensions as shown:

Packaged Height	79.25"
Cut Heights*	73.25"
.....	67.25"
.....	61.25"

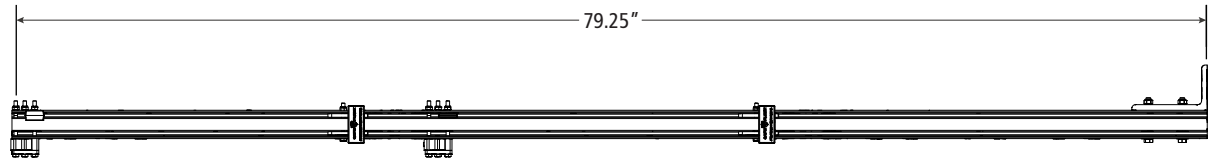
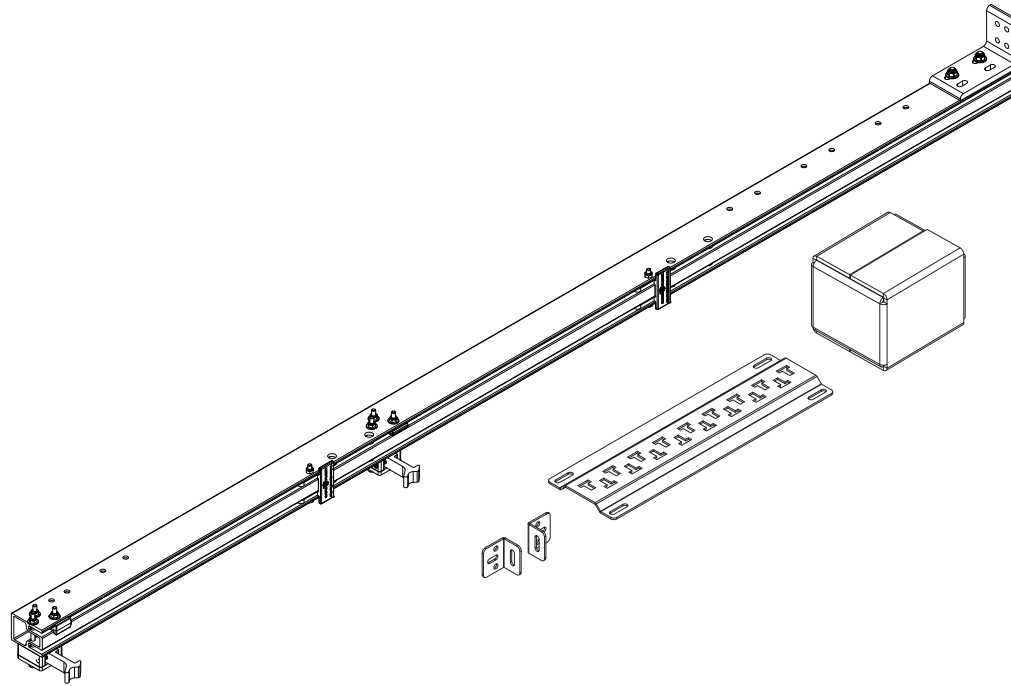

**Note: See Assembly Manual for details on height modifications and cutting.*

Assembly Manual also available:

CSU-3003

USOV-CSU3003-US01 Rev-A 0121