

PRIME DESIGN™

A Safe Fleet Brand

CSU-3015

Cantilever Shelf Upright
Promaster Cargo Van

Approximate dimensions as shown:

Height..... 62.125"

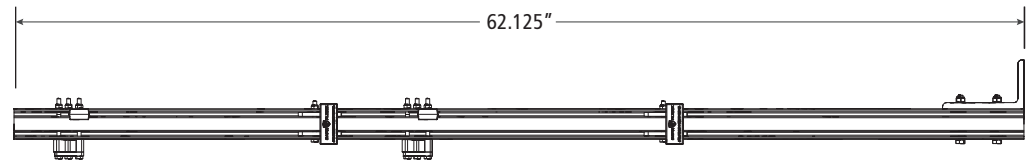
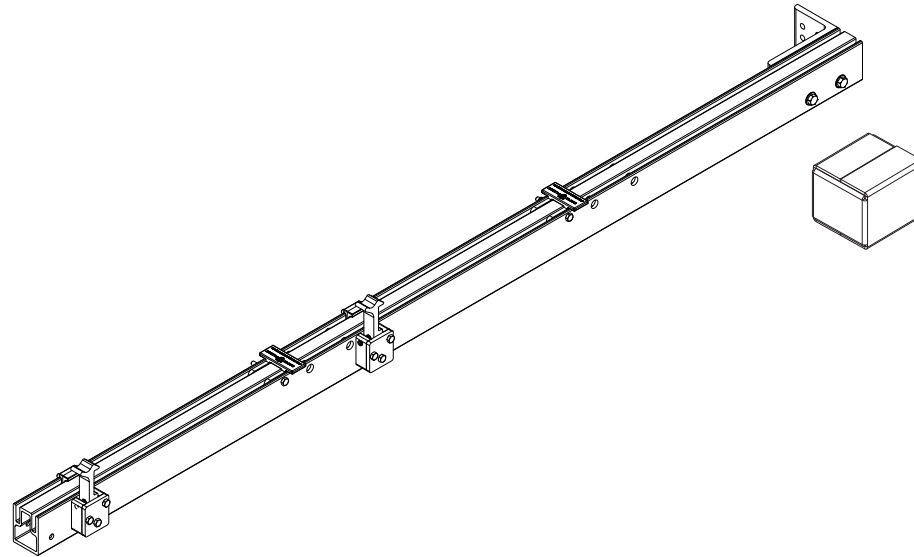

**Note: See Assembly Manual for details on height modifications and cutting.*

Assembly Manual also available:

CSU-3015

USOV-CSU3015-US01 Rev-A 0621