

PRIME DESIGN™

A Safe Fleet Brand

CSU-3100

Cantilever Shelf Wheel Well Upright Support

Configuration as shown:

Weight: 8 lbs

Approximate dimensions as shown:

A: Overall Width	44.00"
B: Channel Width	38.00"
C: Height	12.00"

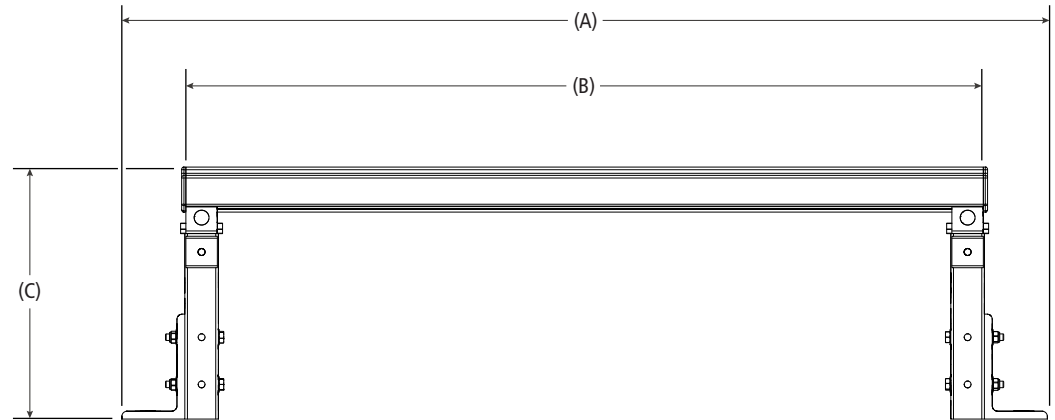
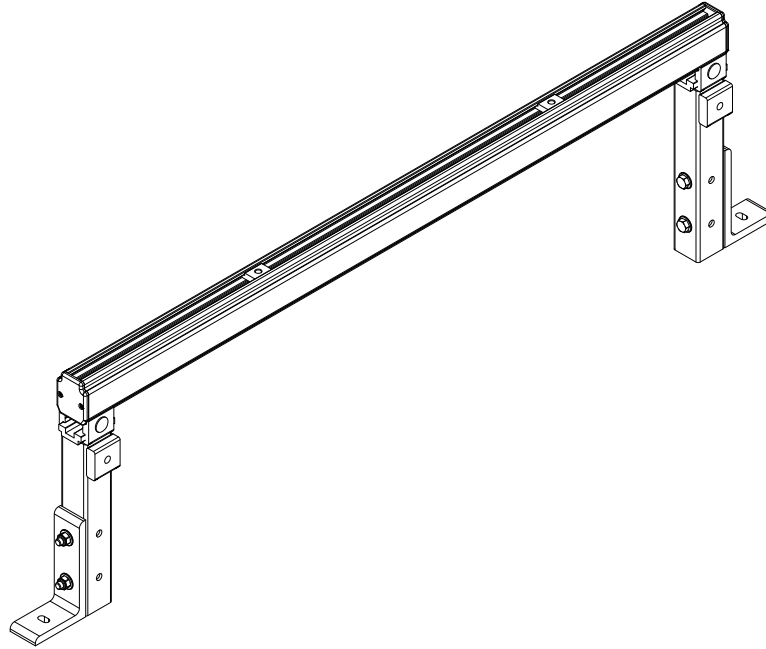

Assembly Manual also available:

CSU-3100

USOV-CSU3100-US01 Rev-A 0121