

CSS-5002

Cantilever Shelf Pair

Configuration as shown:

48" Length x 24" Width

Weight: 45 lbs

Approximate dimensions as shown:

A: Distance Between Uprights 32.125"

B: Shelf Height 24"

C: Shelf Length 48"

**Mounting Hardware ordered separately*

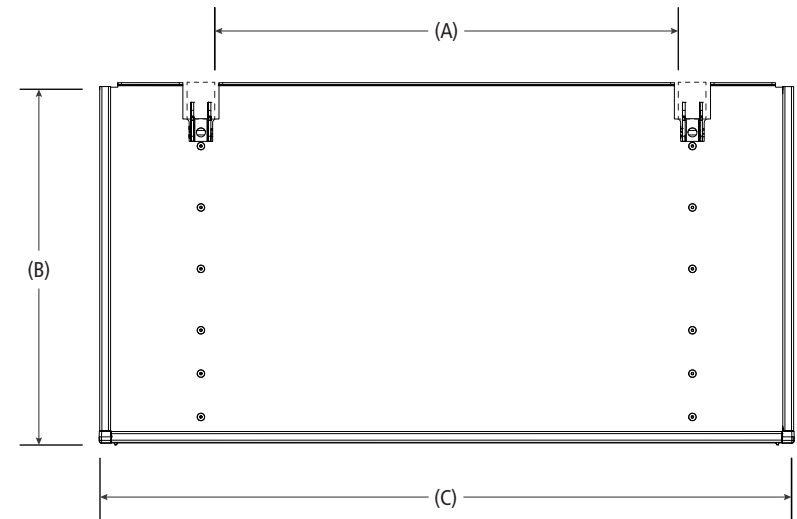
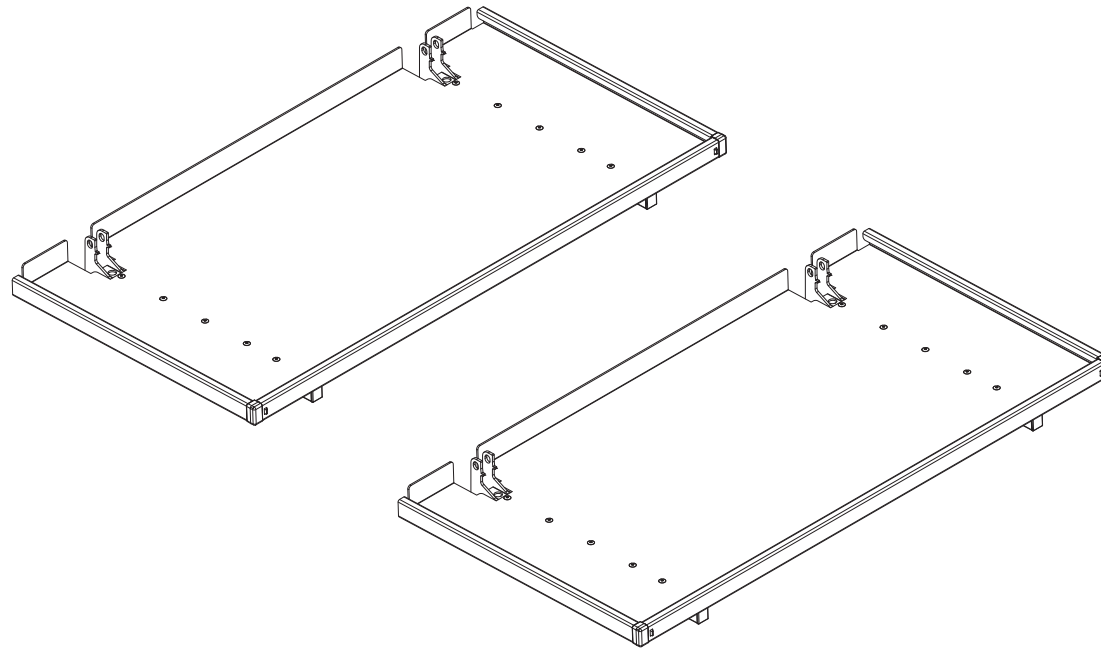

**Note: Mounting Hardware purchased separately. For more information, please contact Sales & Support.*

Assembly Manual also available:

CSS-5000 Series

USOV-CSS5002-US01 Rev-A 0221