

CSS-5011

Cantilever Shelf Pair

Configuration as shown:

70" Length x 24" Width

Weight: 61 lbs

Approximate dimensions as shown:

A: Distances Between Uprights 54.125"

A: Height 24"

B: Length 70"

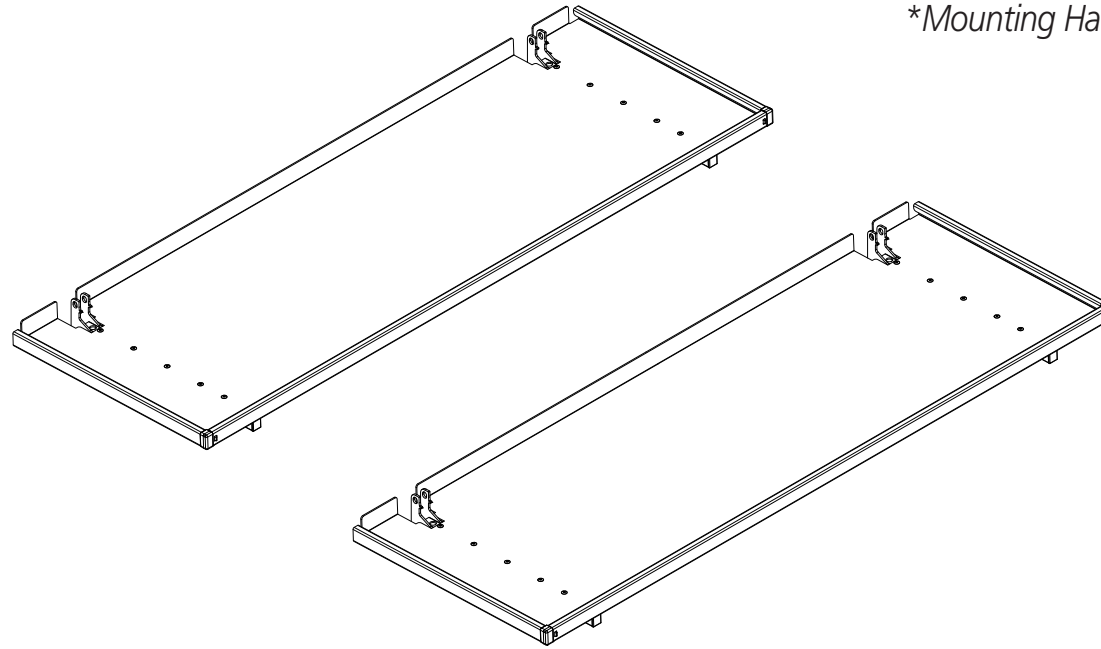

**Mounting Hardware ordered separately*

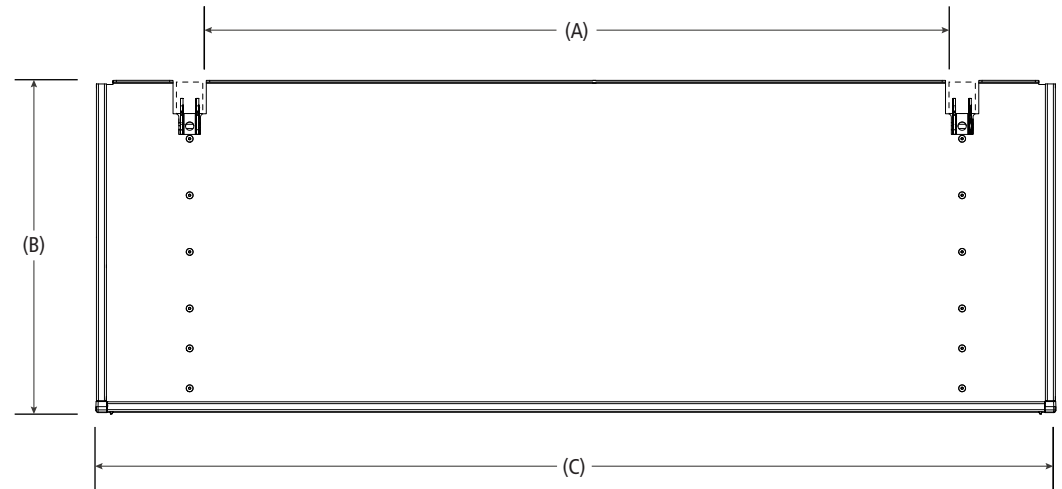

**Note: Mounting Hardware purchased separately. For more information, please contact Sales & Support.*

Assembly Manual also available:

CSS-5000 Series

USOV-CSS5011-US01 Rev-A 0421