

# PRIME DESIGN™

A Safe Fleet Brand

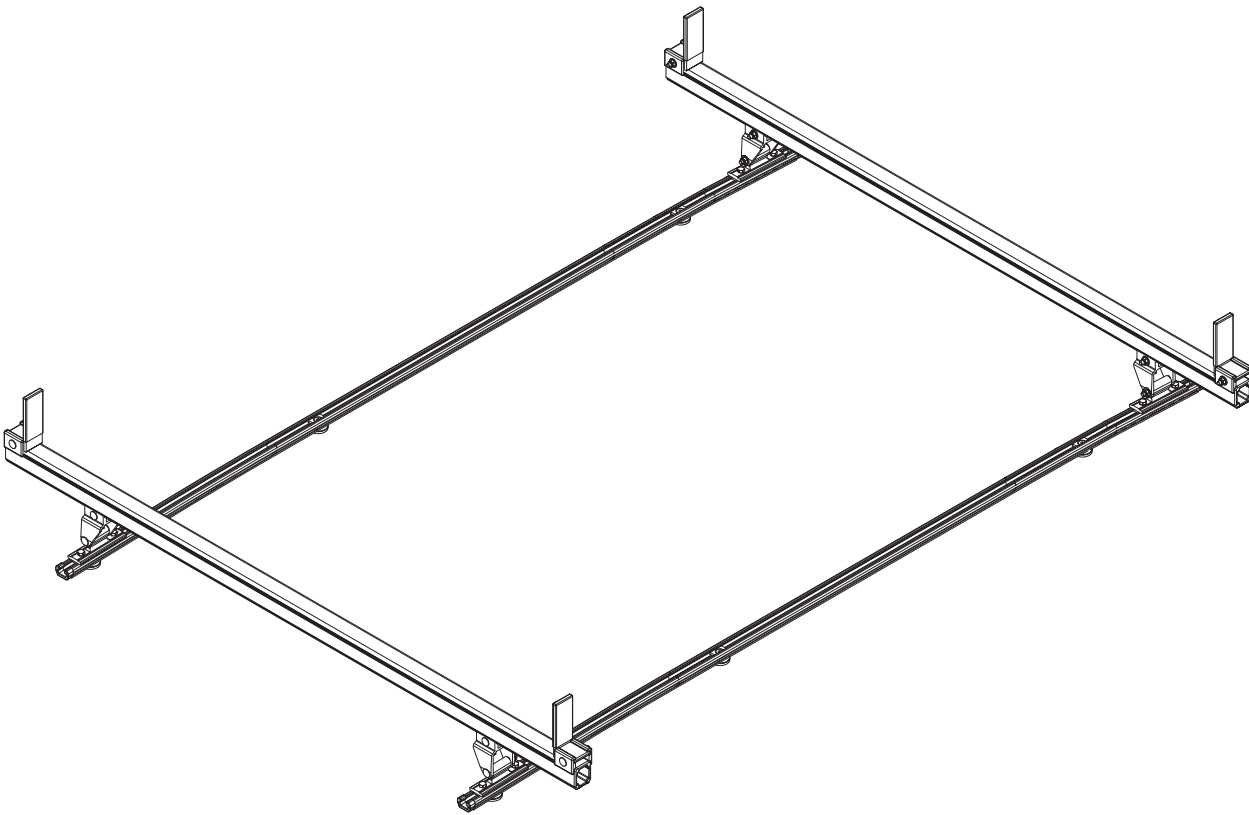

**VBB**  
**ONE**

# CONTENTS OVERVIEW

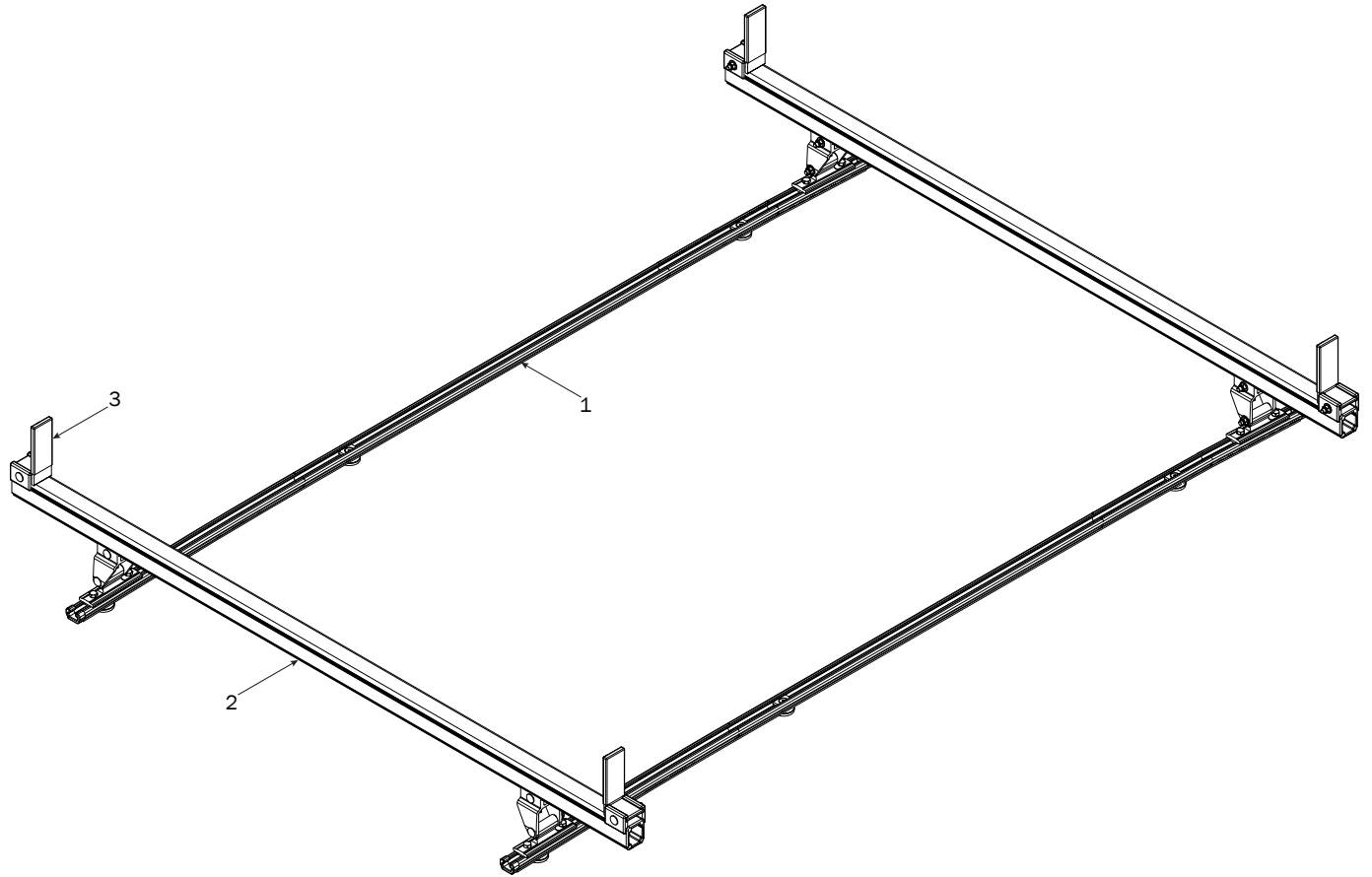

1—FBM-0045 ..... (Qty 1)  
Channels with hardware



End Caps (4X)



Brackets (4X)

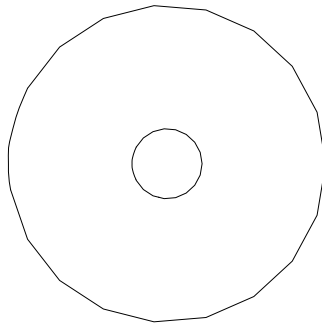

Nylon Washer (6X)

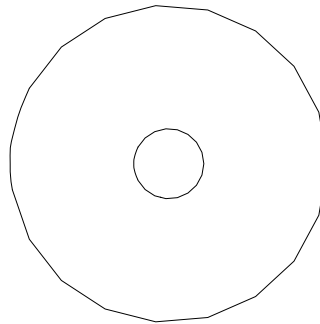

Foam Gasket (6X)

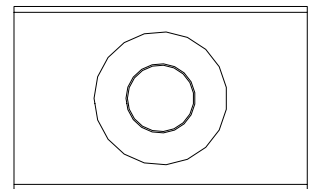
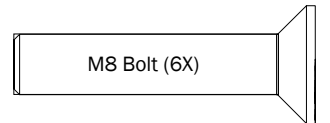

Flex Channel Connector (6X)

2—Crossbar Assembly..... (Qty 2)

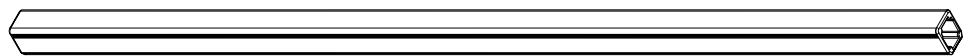

3—Ladder Stop Assembly ..... (Qty 4)  
1.75"

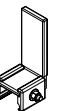

# FBM-0045 CHANNELS TO ROOF

**0.1** Position Channels as shown below in Fig.1

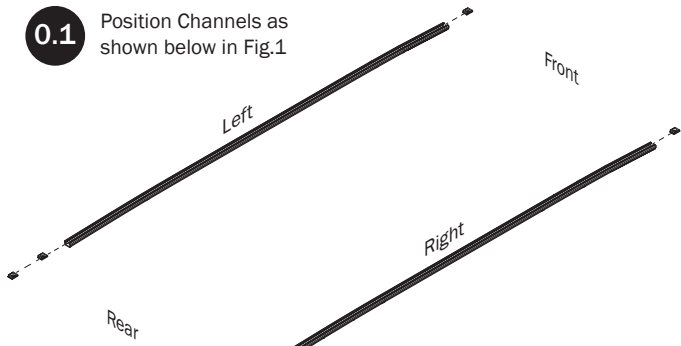

Slide Channel Connectors into Channels as shown

**0.2**

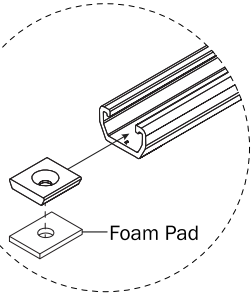
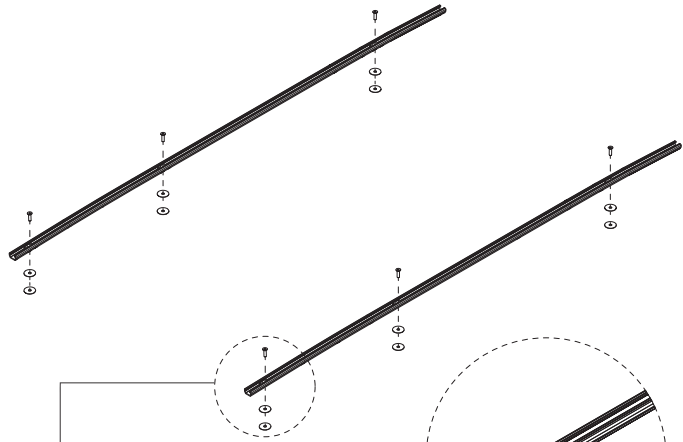

Fig. 1



**0.3** Install Channels into roof Channel groove as shown



**0.4** Install fasteners into factory roof rail mounting locations.

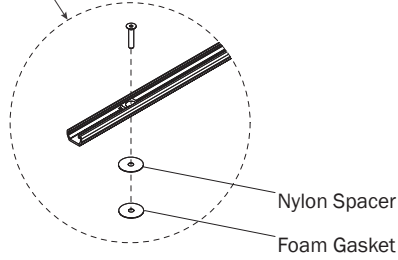

**0.5**

Torque to 150 in-lbs

**0.7** Set to distances then torque Rear Bracket nuts to 90 in-lbs

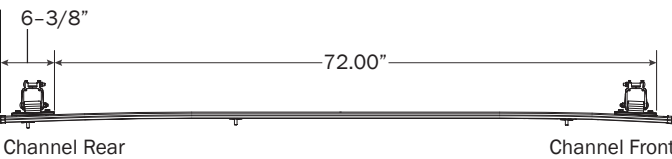
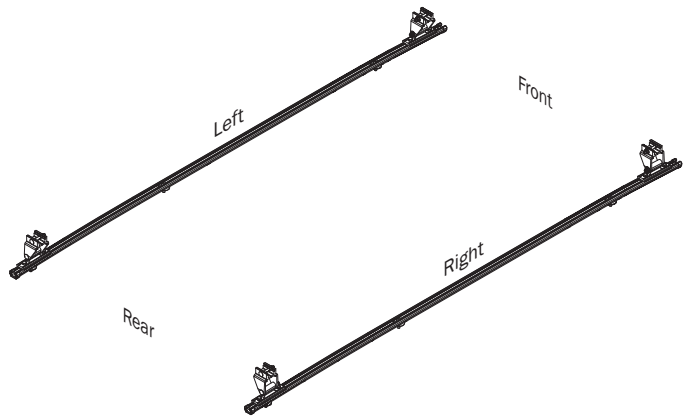

**0.6** Loosen bolts



# BASE ASSEMBLY

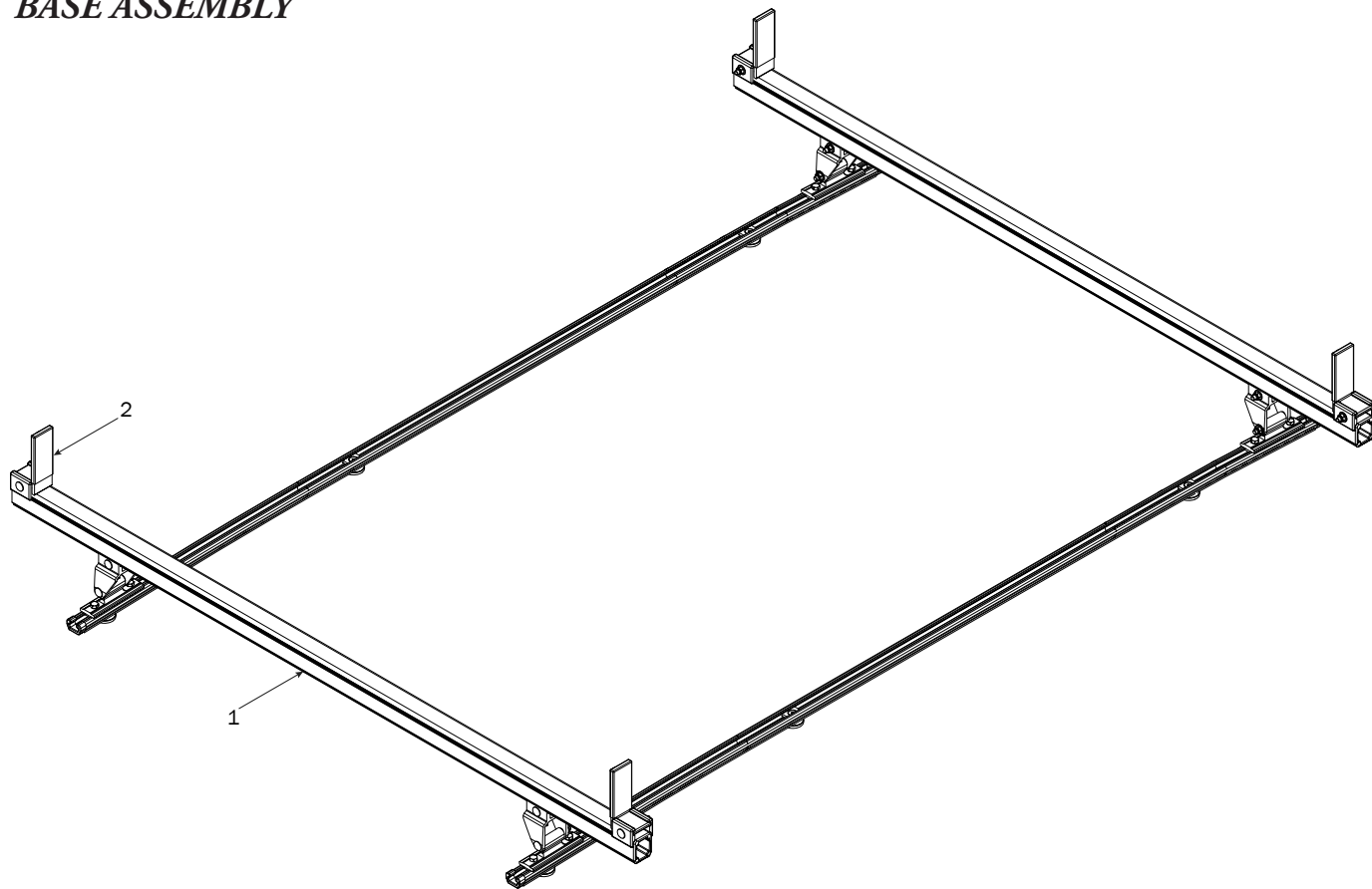

## CROSSBARS

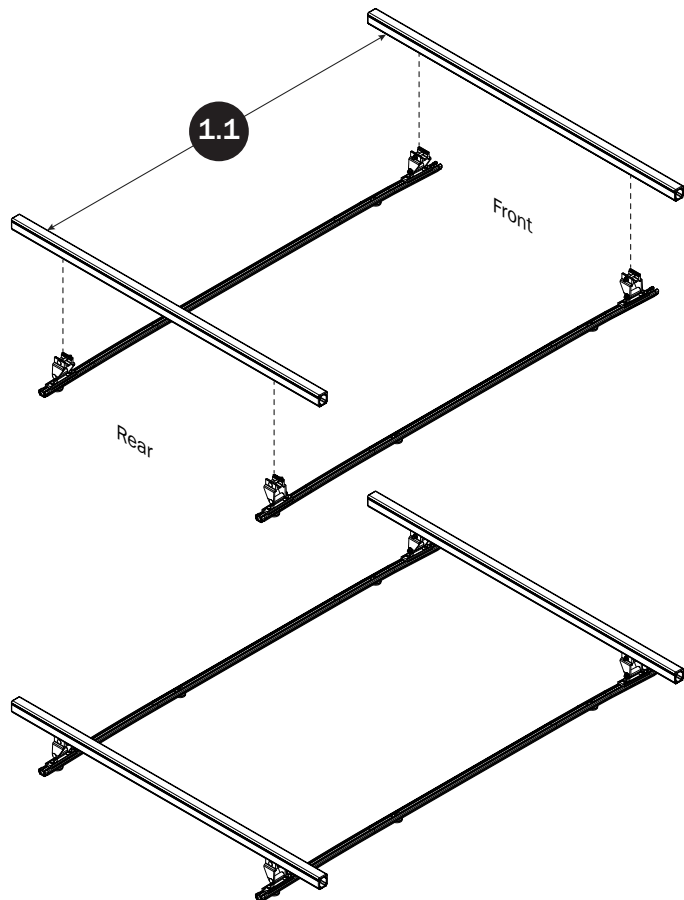

## CROSSBAR ADJUSTMENT

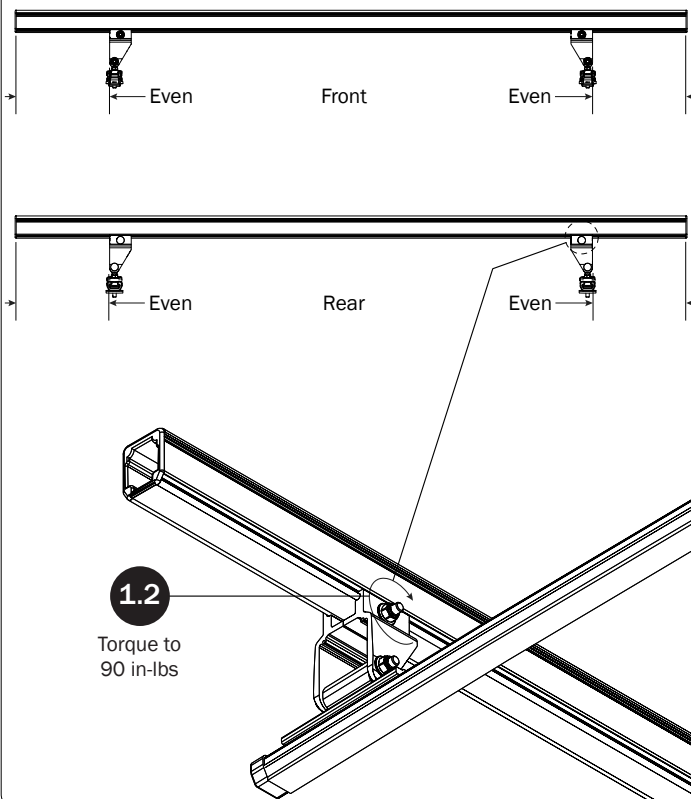

## LADDER STOPS

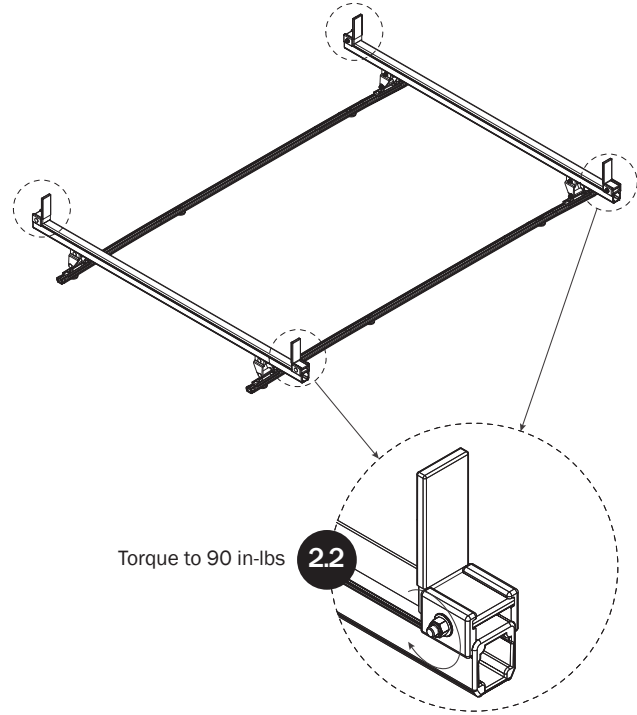
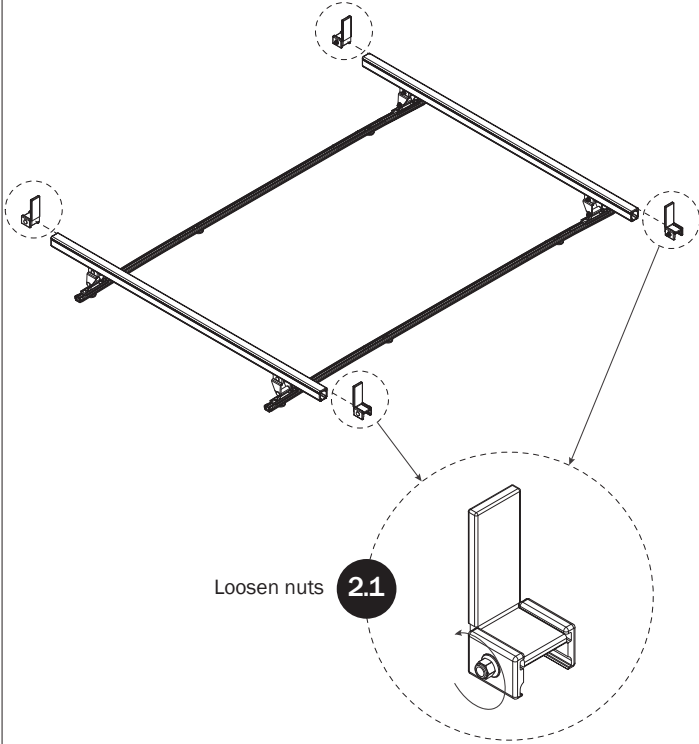

Page Intentionally Left Blank

Page Intentionally Left Blank

