

PRIME DESIGN™

A Safe Fleet Brand

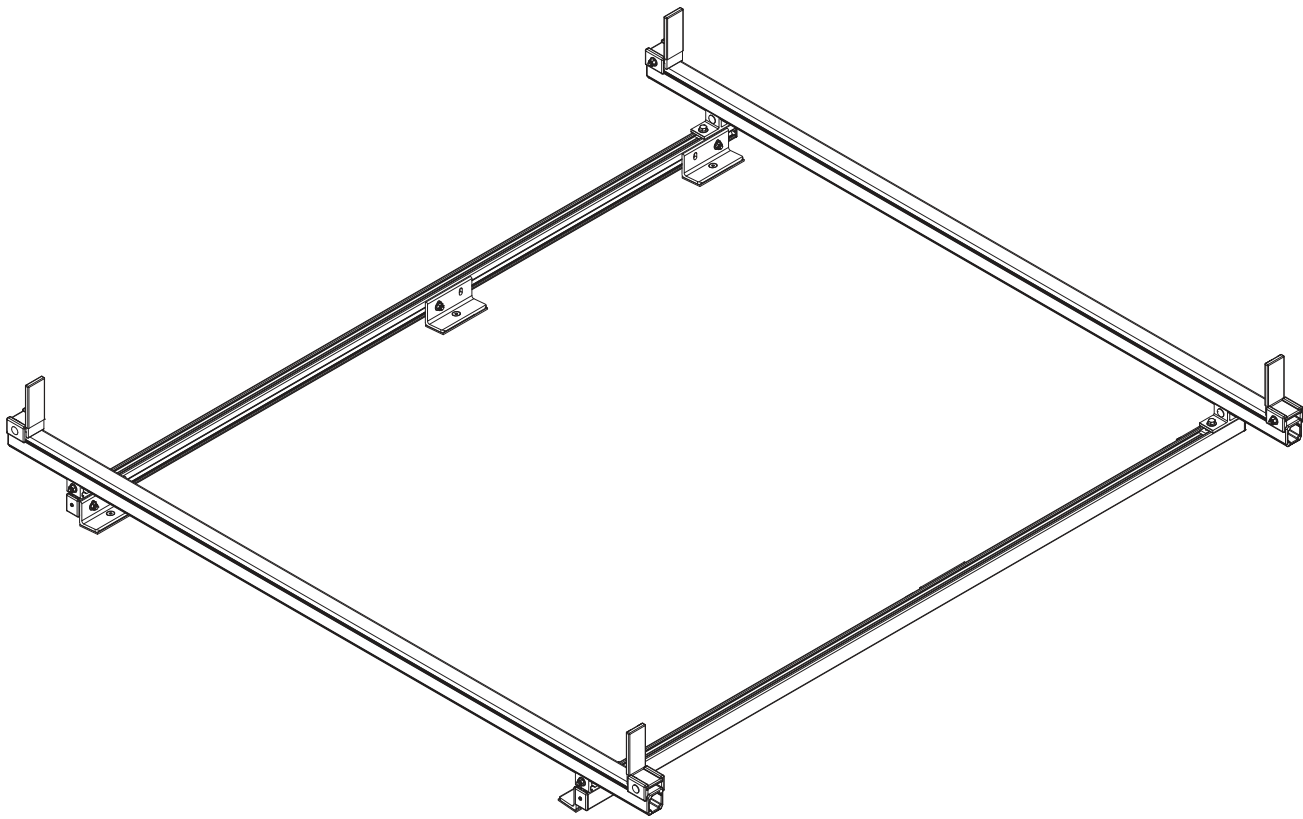

VBB **H'N'B**

CONTENTS OVERVIEW

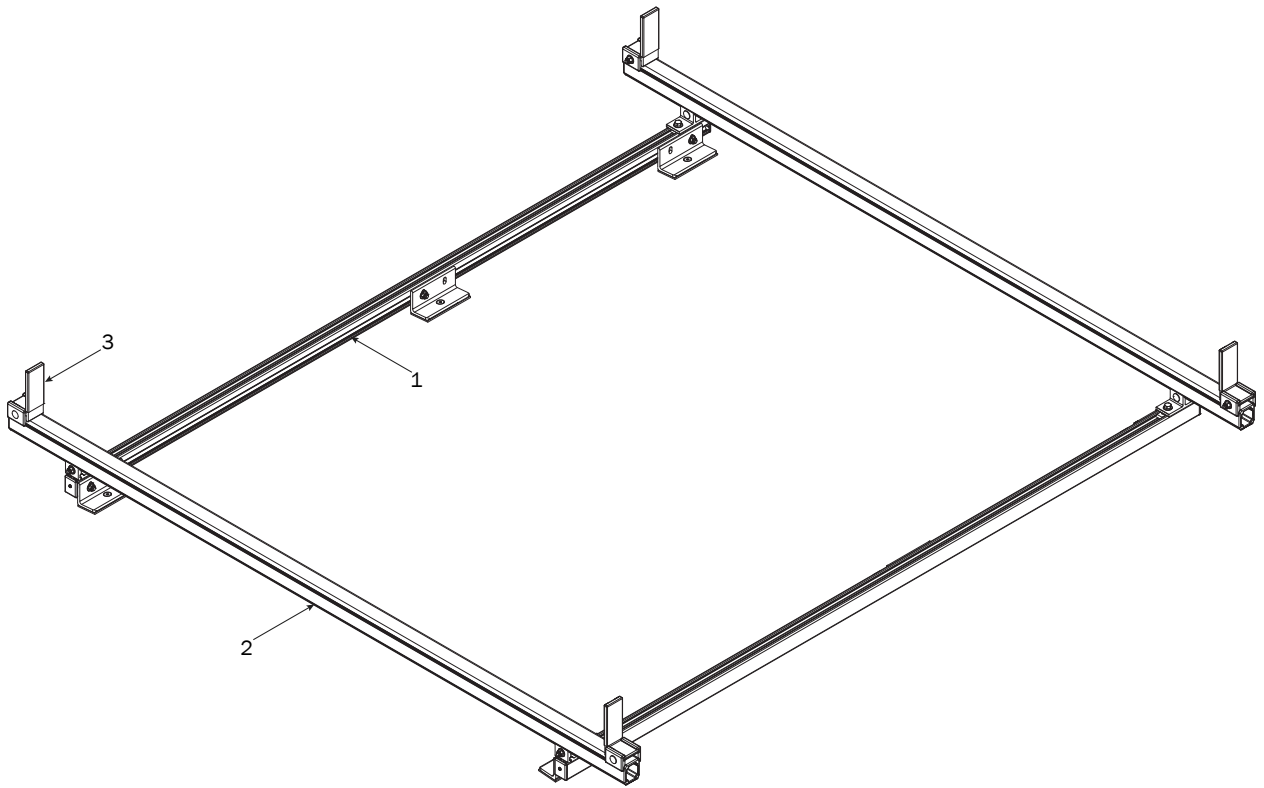

1—FBM-0096 (Qty 1)
Channels w/ Hardware

74" Channels, Pre-assembled (2X)

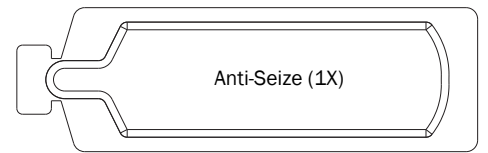
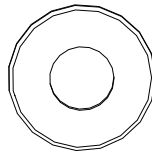
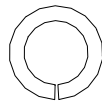
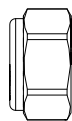
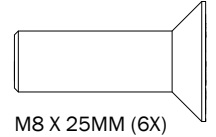
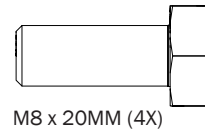
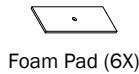

2—Crossbar Assembly..... (Qty 2)

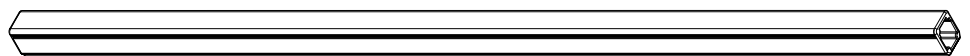

3—Ladder Stop Assembly (Qty 4)
1.75"

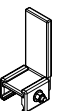

BASE ASSEMBLY SEQUENCE



Prior to assembling the Channels and hardware, the OEM roof holes must be chased using an M8 x 1.25 Chasing or Thread Cleaning tap and fluid. Doing so will ensure accurate torque is achieved.

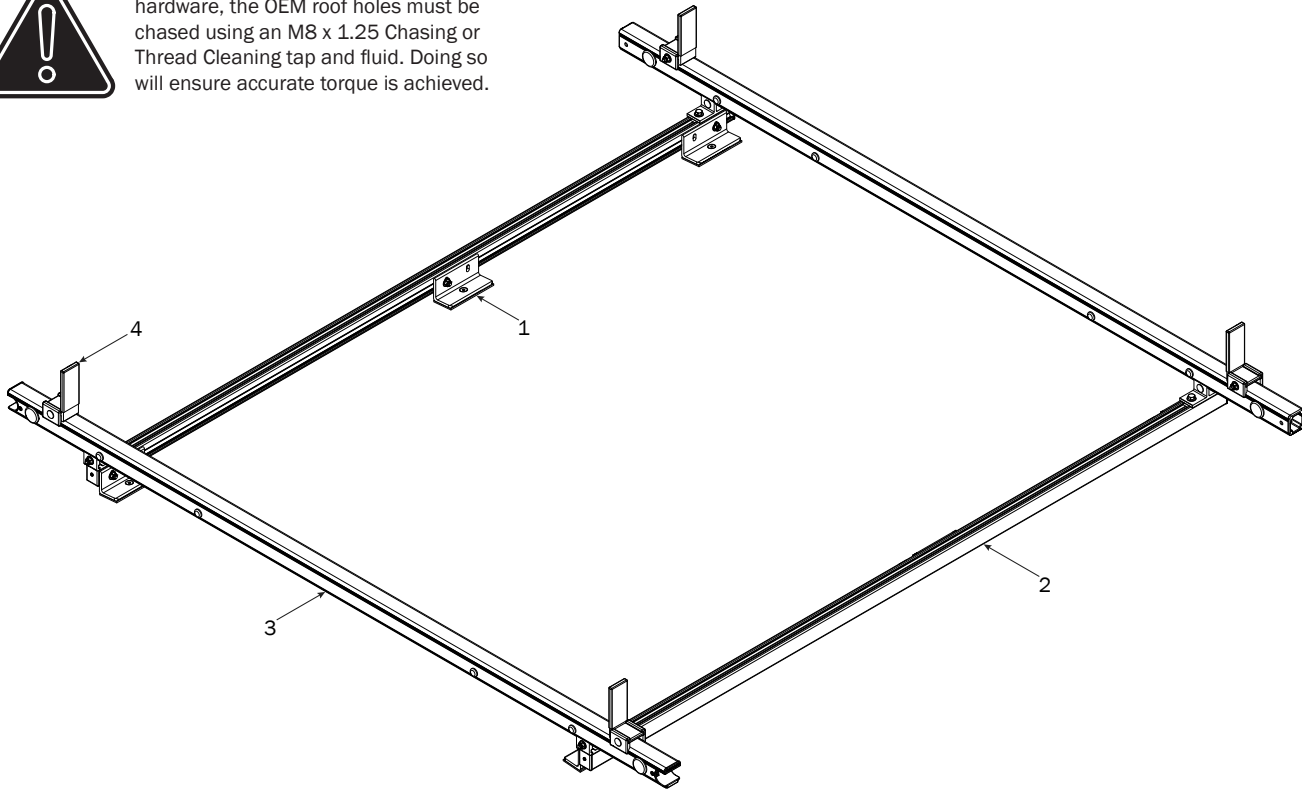

MOUNTING BRACKETS

- 1 Apply Anti-Seize to all M8 x 25MM Flat Head Screws and install the Channel Mounting Brackets with Foam Pads onto the vehicle's roof mounting holes. Do not tighten screws until Step 2.3

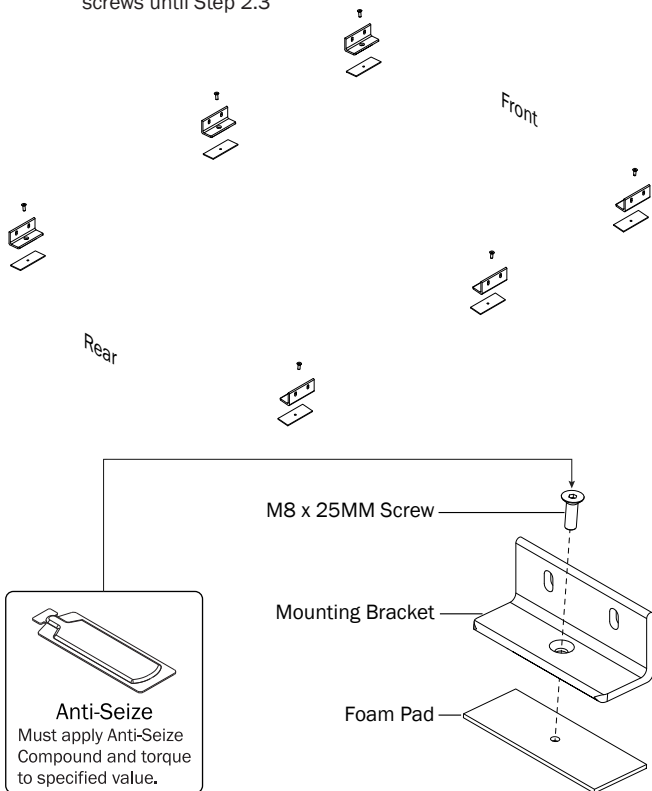

CHANNELS

- 2.1 Apply Anti-Seize to all M8 T Bolt studs, then attach the Channels to the Mounting Brackets using the indicated hardware. Do not tighten until Step 2.2

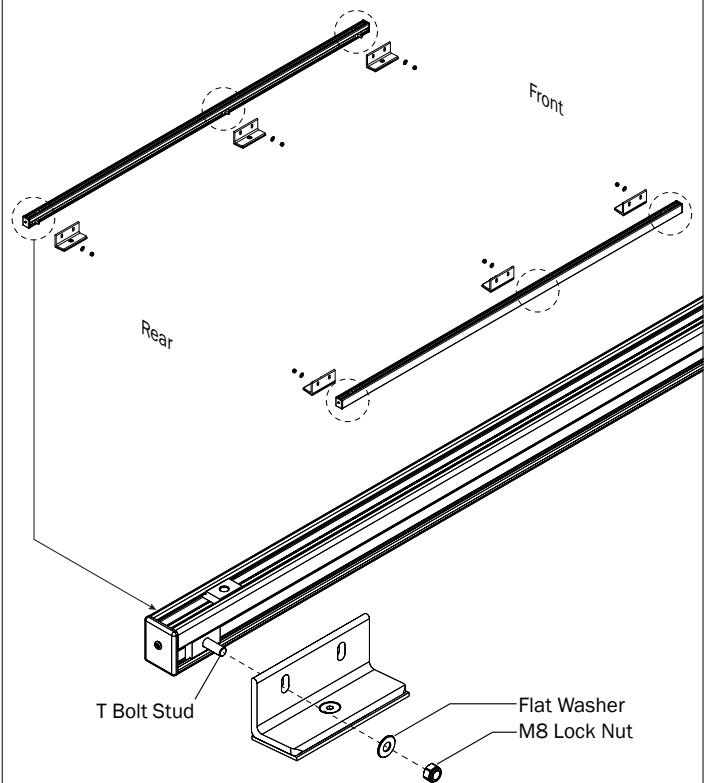

2.2 Position the Channel ends until contacting the End Caps as shown in Figure A.

Torque all Mounting Bracket Nuts to 90 in-lb

Fig. A

Flush

Front

Rear

2.3 Torque all M8 x 25MM Flat Head Screws to 150 in-lbs. Apply Silicone Sealant to screw heads to seal against water intrusion.

Front

Rear

Apply silicone sealant (not provided) to screws

2.4 Attach Mounting Brackets to the Aluminum Strip Nuts located in the Channels

Position the rear Mounting Brackets as shown.

Position the front Mounting Brackets as shown.

Left

Right

Front

Rear

M8 X 20MM

Lock Washer

Flat Washer

2.5 Loosen nuts

2.6 Position Mounting Brackets to designated dimension shown below, then torque the M8 X 20MM bolt to 90 in-lbs. Proceed to Step 3.1.

Left

Right

Front

Rear

Flush

(A) 72.00"

Channel Rear

Channel Front

CROSSBARS

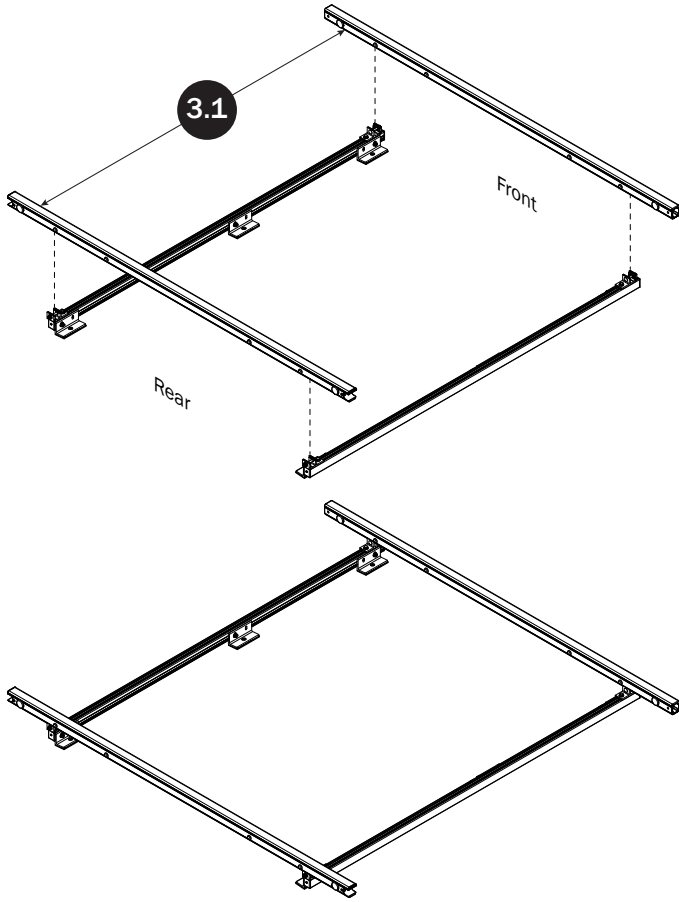

CROSSBAR ADJUSTMENT

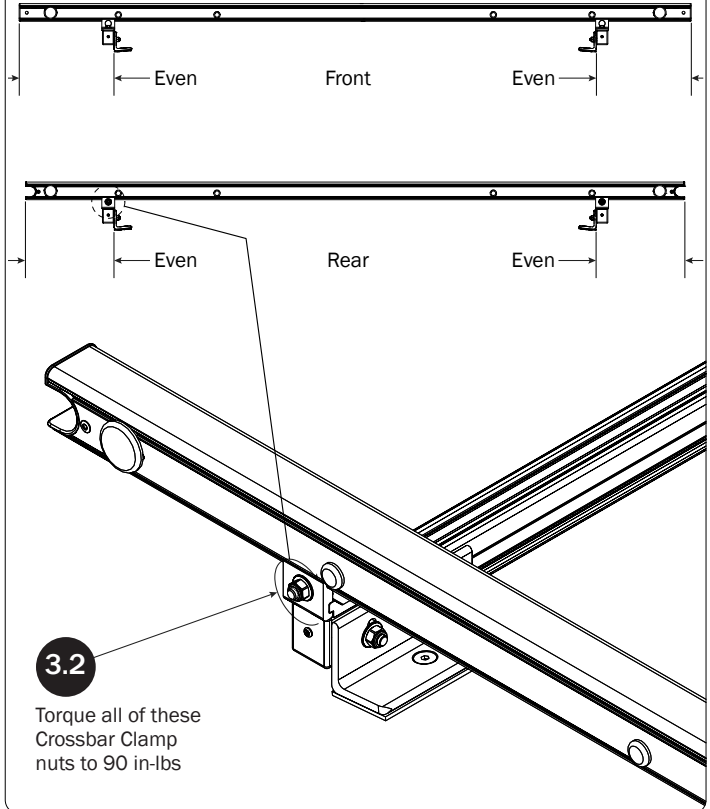

LADDER STOPS

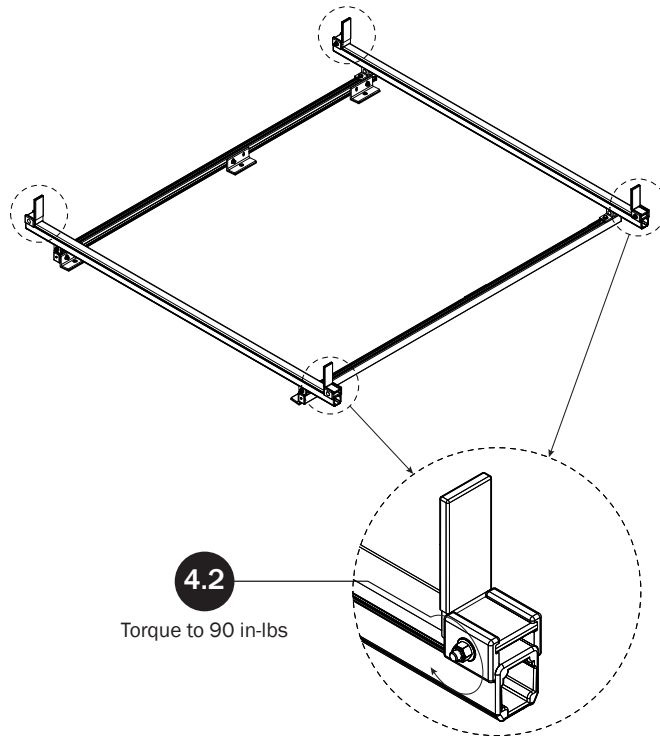
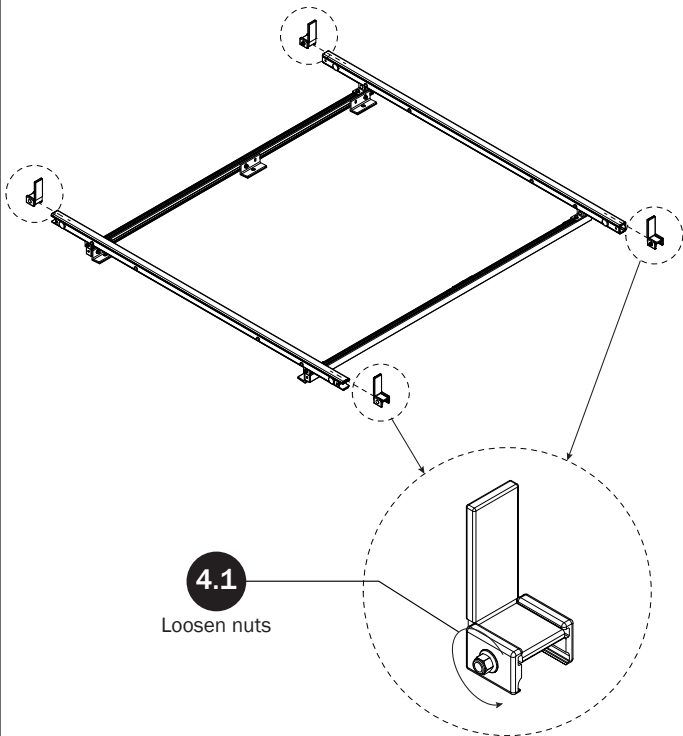

Page Intentionally Left Blank

Page Intentionally Left Blank

