

PRIME DESIGN™

A Safe Fleet Brand

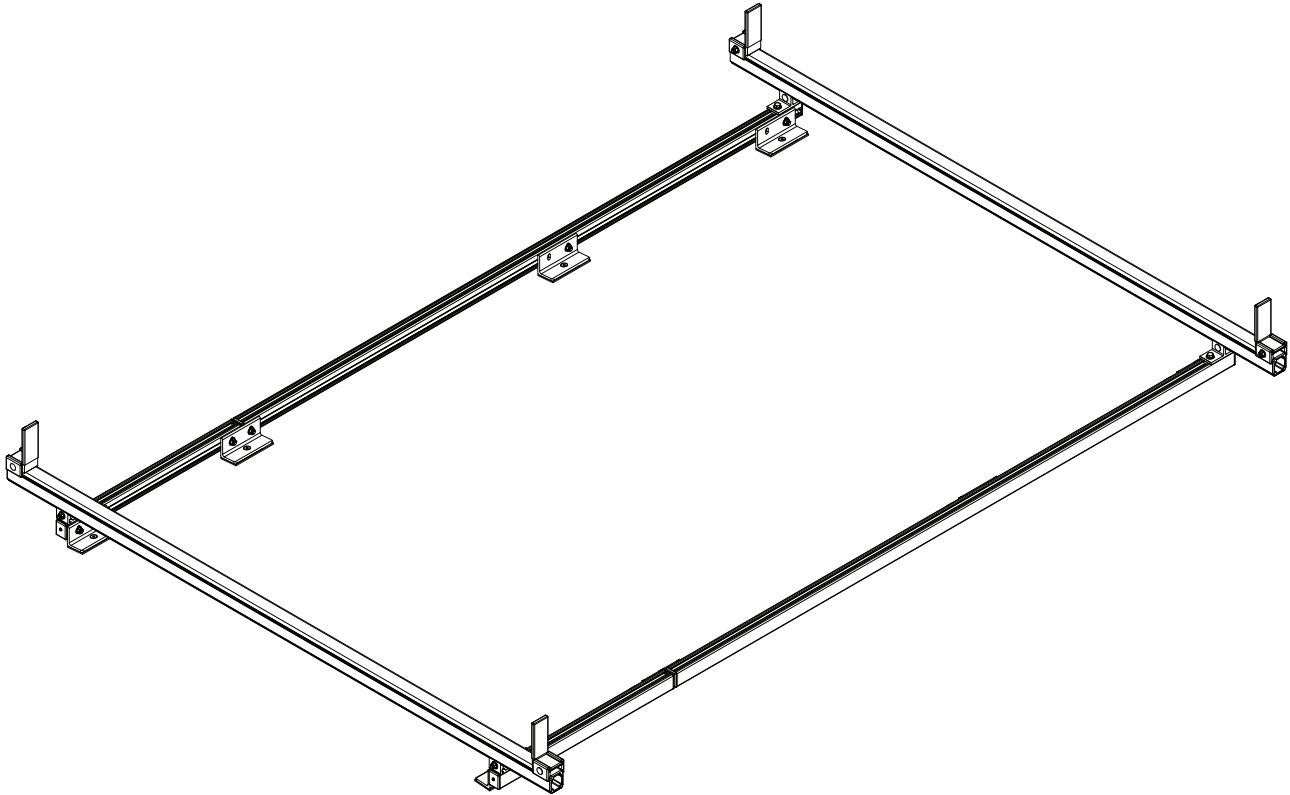

VBB **HUBS** **B**

CONTENTS OVERVIEW

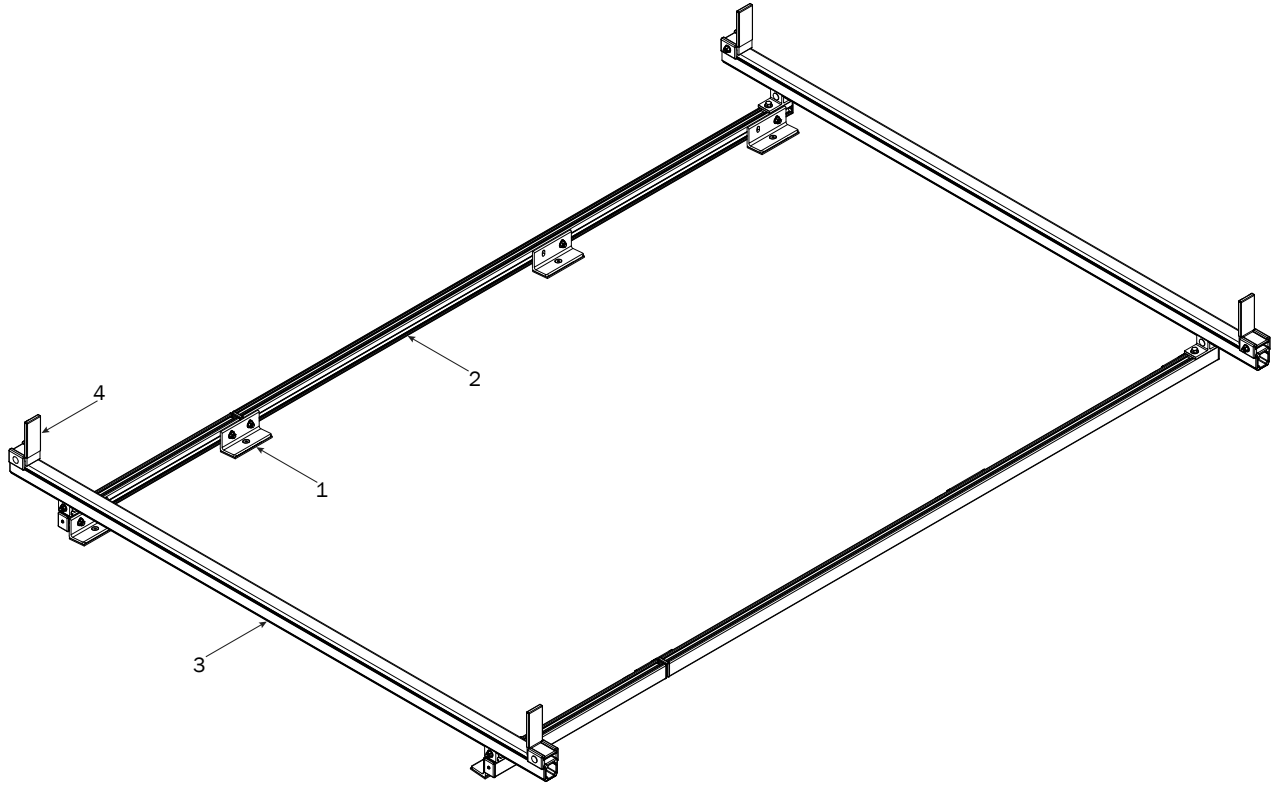

1—FBM-0095 (Qty 1)
Channels w/ Hardware



23" Channels (2X)



74" Channels, Pre-assembled (2X)



Channel Bracket (4X)

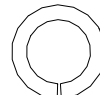

5/16" Lock Washer (4X)

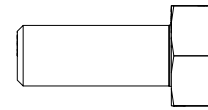

M8 x 20MM (4X)



M8 X 25MM (8X)

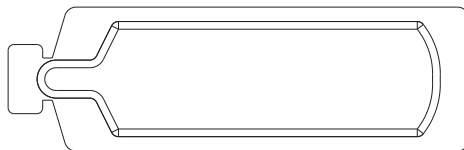

Anti-Seize (1X)



M8 Lock Nut (10X)

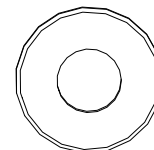

5/16" Flat Washer (14X)

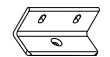

Mounting Bracket (8X)

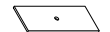

Foam Pad (8X)

2—Crossbar Assembly..... (Qty 2)

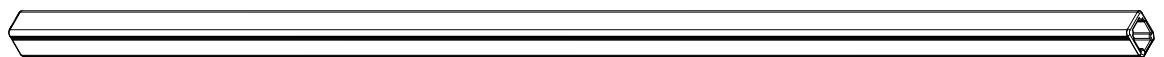

3—Ladder Stop Assembly (Qty 4)
1.75"

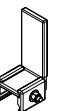

BASE ASSEMBLY SEQUENCE



Prior to assembling the Channels and hardware, the OEM roof holes must be chased using an M8 x 1.25 Chasing or Thread Cleaning tap and fluid. Doing so will ensure accurate torque is achieved.

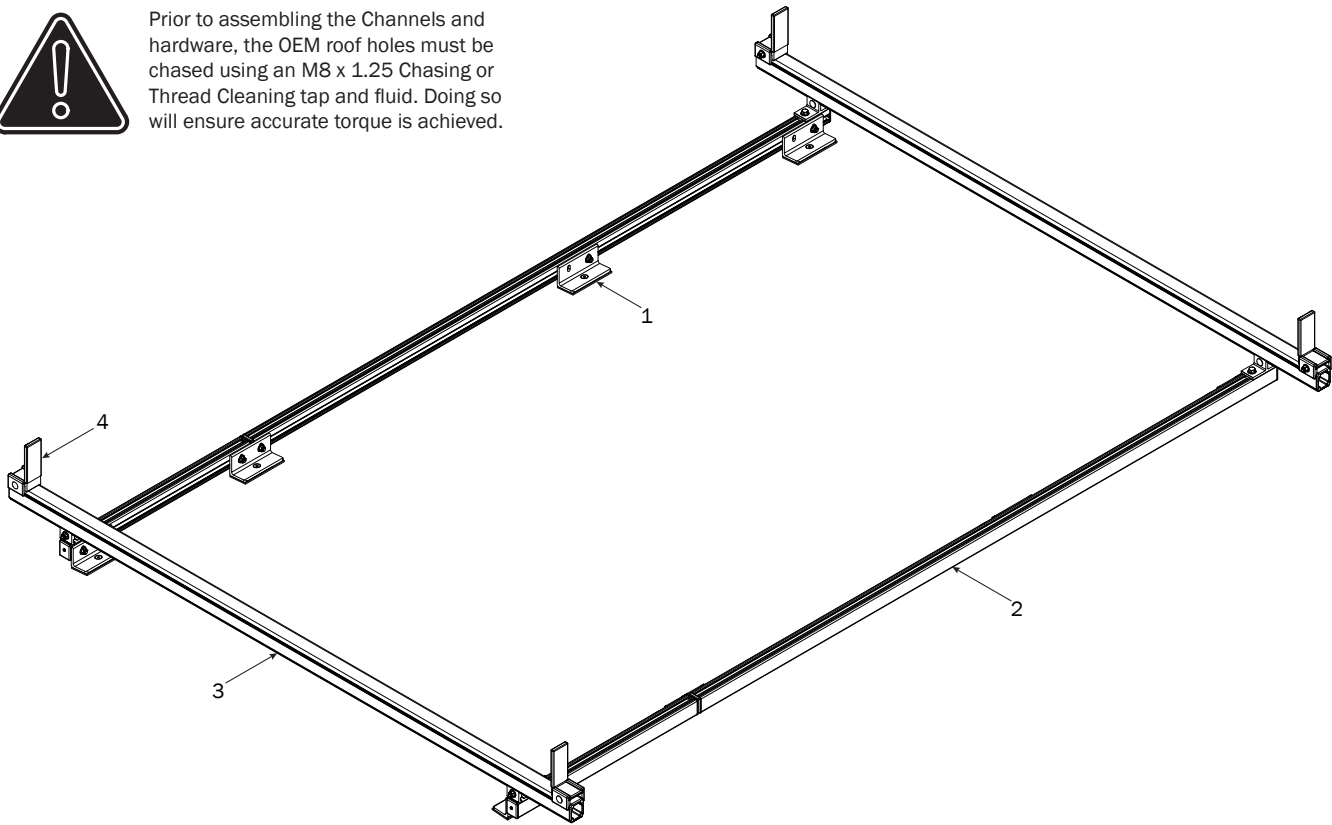

MOUNTING BRACKETS

- 1 Apply Anti-Seize to all M8 x 25MM Flat Head Screws and install the Channel Mounting Brackets with Foam Pads onto the vehicle's roof mounting holes. Do not tighten screws until Step 2.3

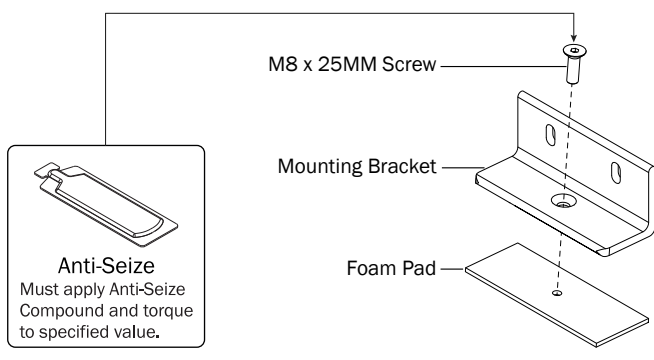
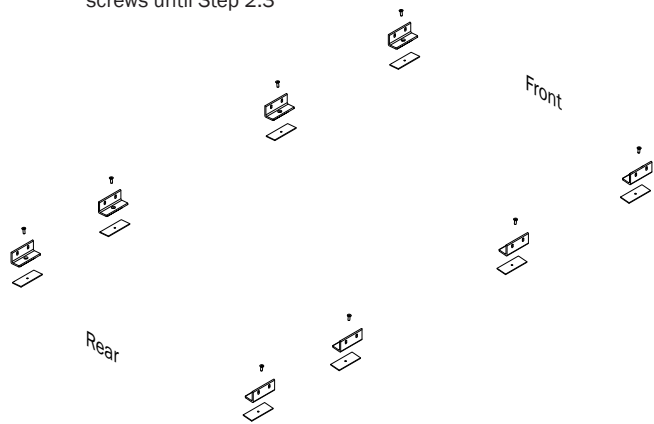

CHANNELS

- 2.1 Apply Anti-Seize to all M8 T Bolt studs, then attach to Mounts using the indicated hardware. Do not tighten until Step 2.2

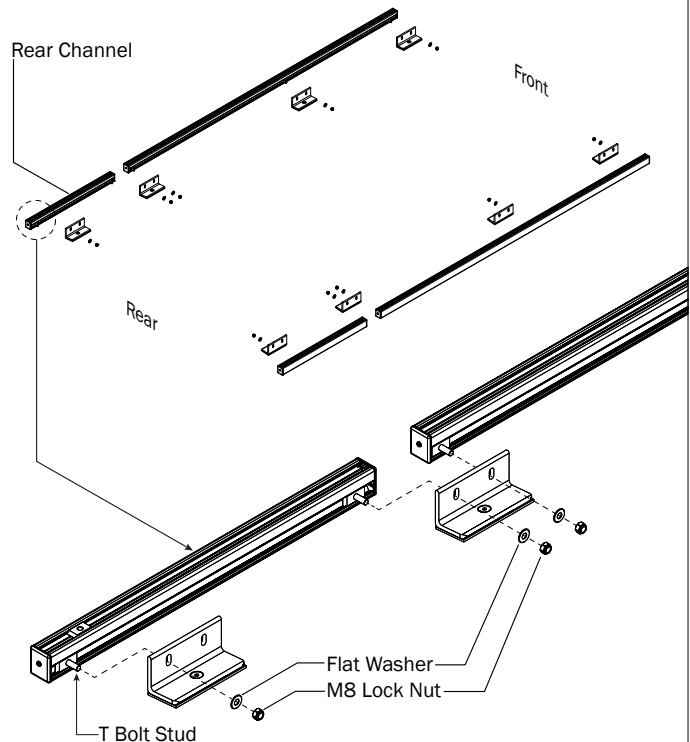



The Front Channels include two aluminum Strip Nuts per Channel for use in a three Crossbar configuration. For two Crossbar configurations, disregard the spare Strip Nut in each Front Channel.

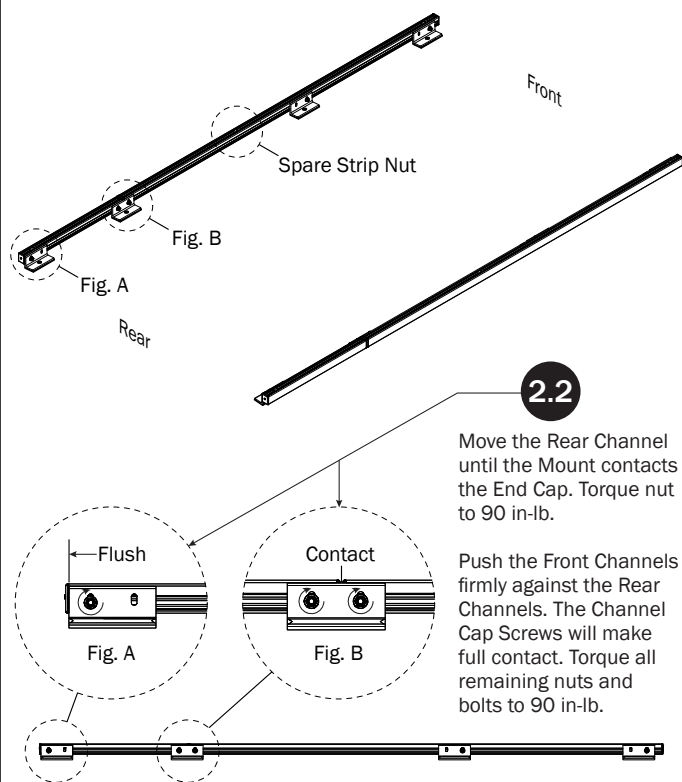

2.3 Torque all M8 x 25MM Flat Head Screws to 150 in-lbs. Apply Silicone Sealant to screw heads to seal against water intrusion.

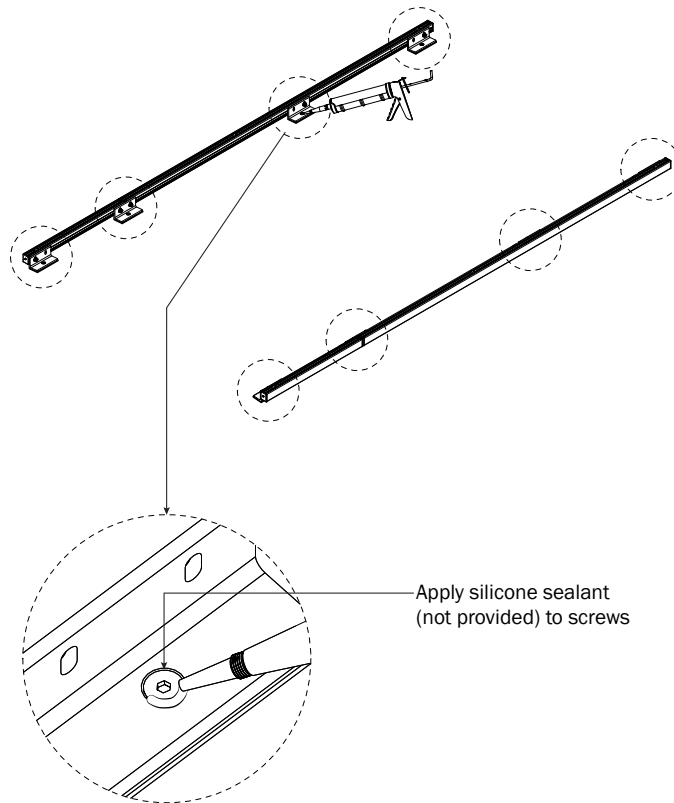

2.4 Attach Mounting Brackets to the Aluminum Strip Nuts located in the Channels

Position the rear and center Mounting Brackets as shown. Position the front Mounting Brackets as shown.

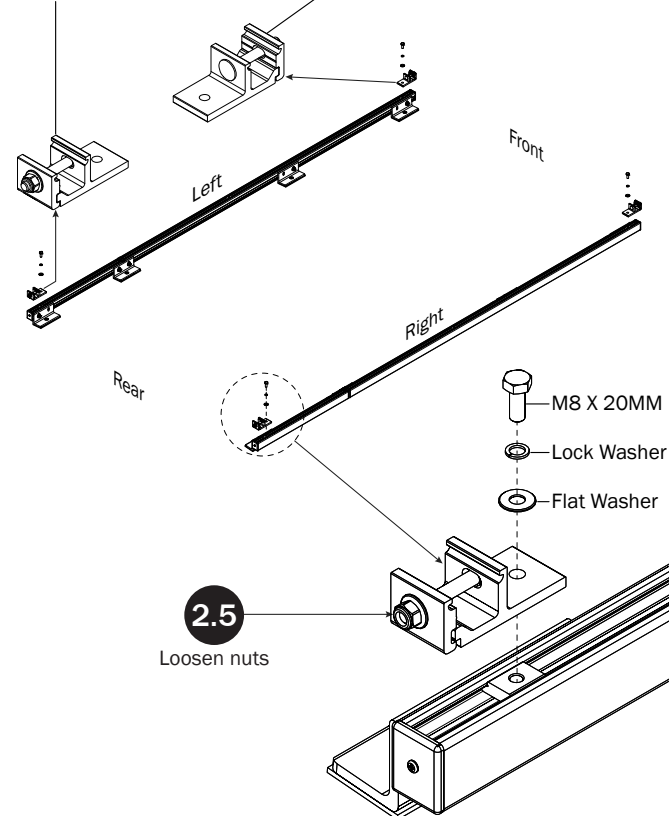

2.6 Position Mounting Brackets to designated dimension shown below, then torque the M8 X 20MM bolt to 90 in-lbs. Proceed to Step 3.1.

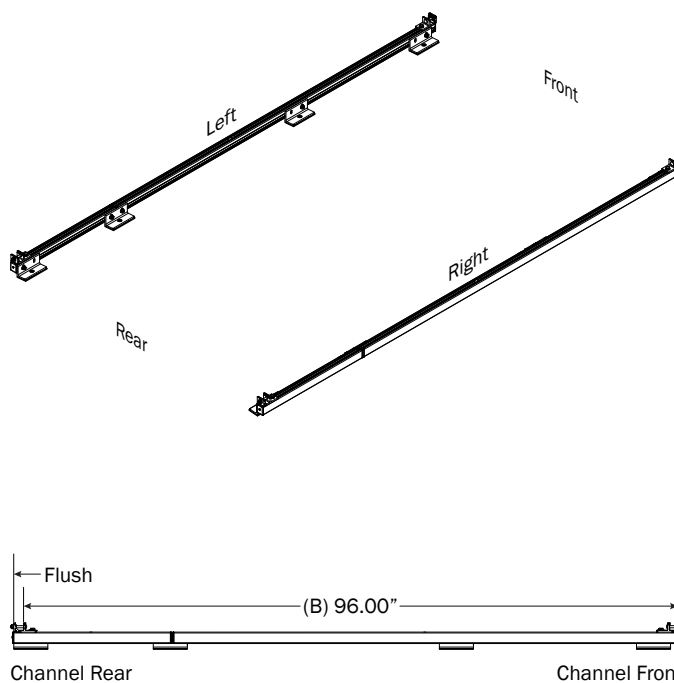

CROSSBARS

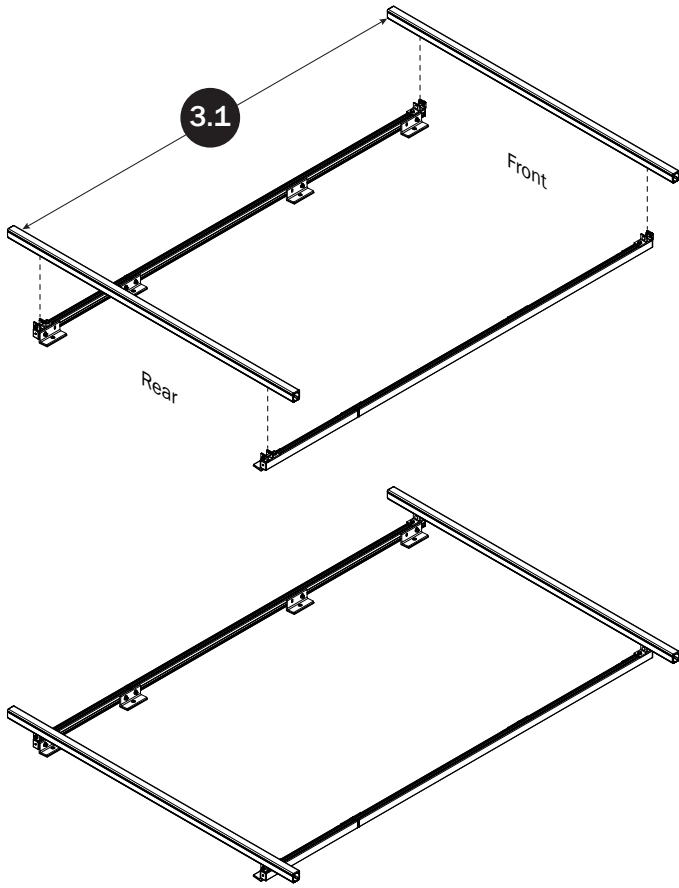

CROSSBAR ADJUSTMENT

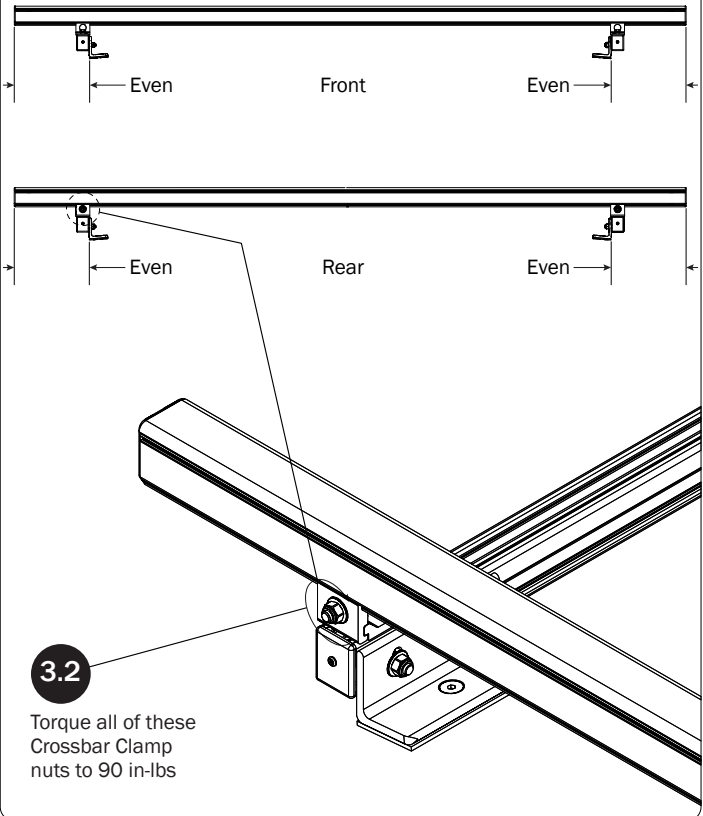

LADDER STOPS

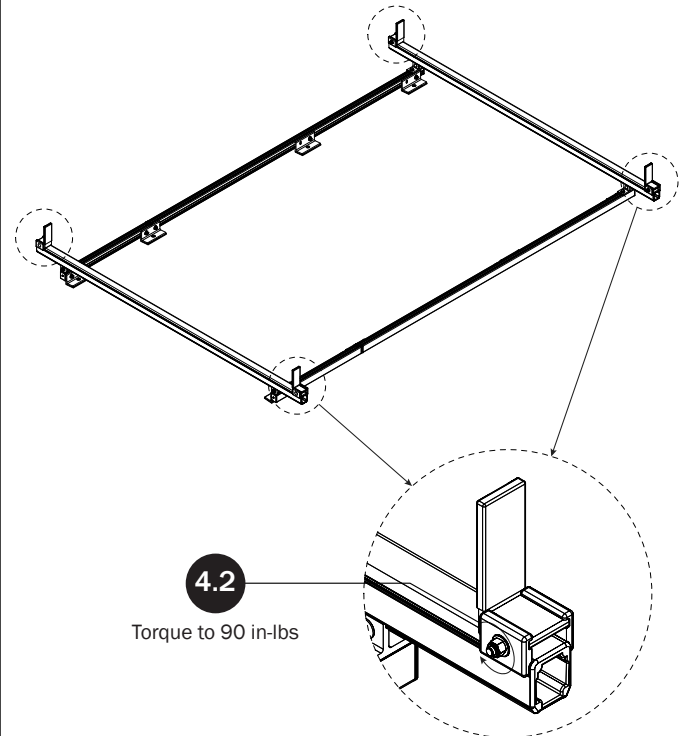
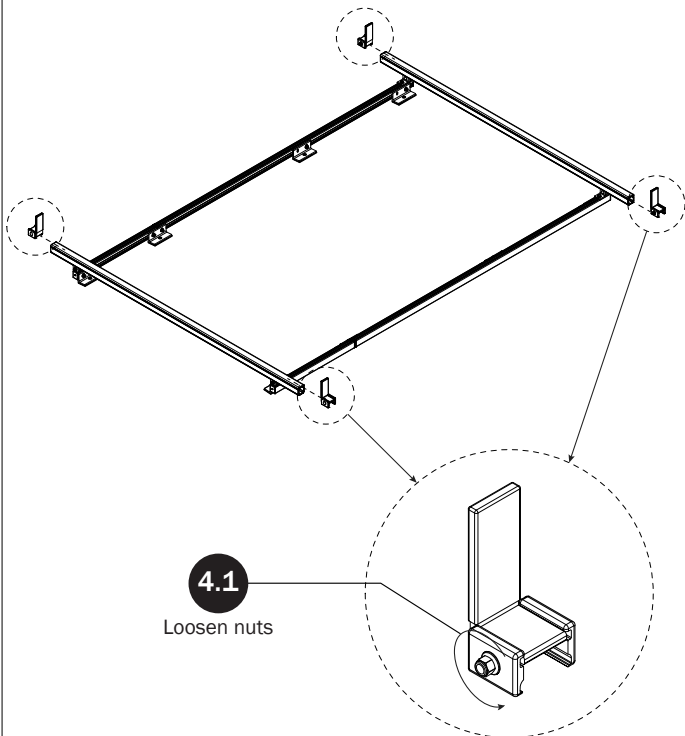

Page Intentionally Left Blank

Page Intentionally Left Blank

