

## PTR-S2

### Pickup Rack, Full Size

Dimensional Specifications on Page 2

#### *Configuration as shown:*

PAR-I Side Rail Assembly, 8' x1  
PUR-7365 Crossbar, 67" w/ Caps x1  
PAR-8461 Frame Side Rail to CBR Connector x6  
PTR-R2 Roller Assembly x1  
Finish: Anodized Aluminum  
Rack Weight (empty): 38 lbs

#### *Load specifications as shown:*

Check the vehicle manufacturer's  
recommendation for roof capacity weight limit.

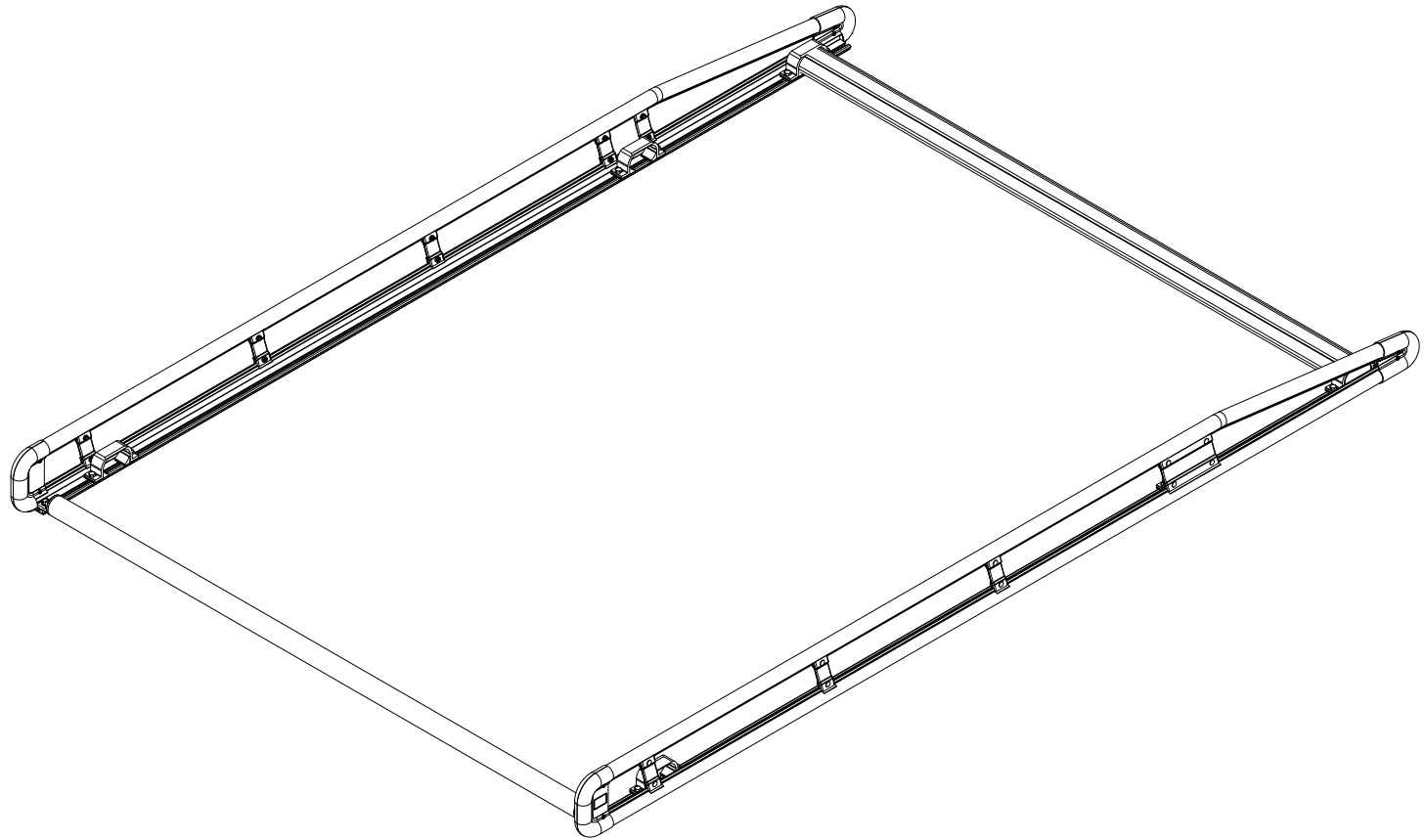

## PTR-S2

### Pickup Rack, Full Size

Approximate dimensions as shown:

- A: Rack Width ..... 70"
- B: Rack Height ..... 7"
- C: Rack Length ..... 103"
- D: Roller offset ..... 6"

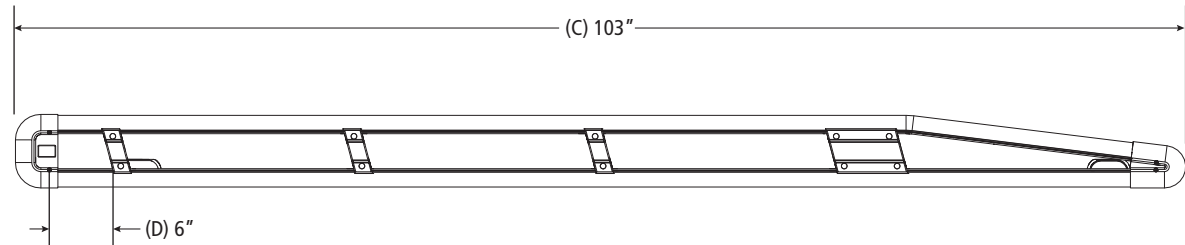
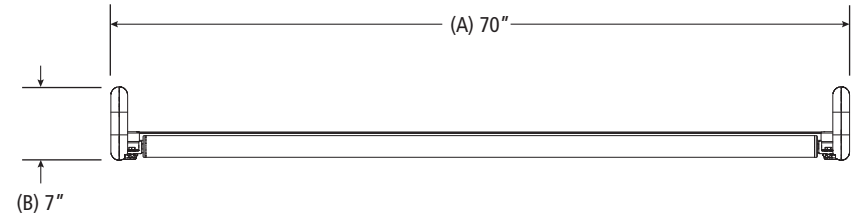
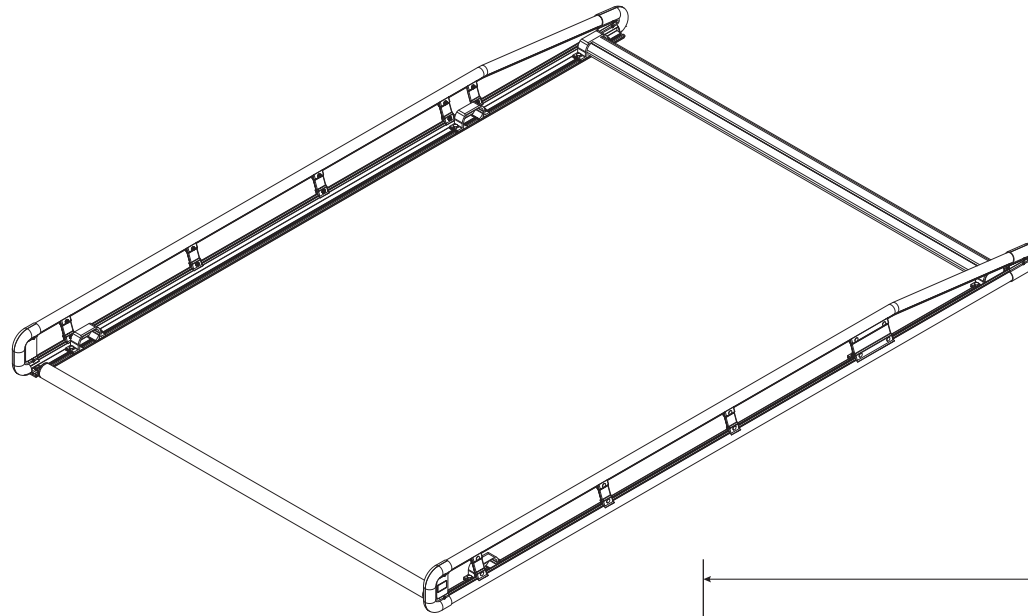

Assembly Manual also available:

## PTR-S2

USOV-PTRS2-US01 Rev-A 0418