

PRIME DESIGN™

A Safe Fleet Brand

AR1903

AluRack Transit Connect L1H1

Configuration as shown:

Anodized Aluminum
Rack Weight (empty): 49 lbs

*Callouts in this Configuration Overview indicate full module assemblies only.

For details on individual parts, please refer to the linked Module Overviews below.

AR1903 (Clear Anodized)

A: [FBM-1012-BLK Mounting System](#)
B: [AR-2101 84" Side Rail Feature](#)
C: [AR-2000 53" Crossbar Feature](#)

AR1903-BLK (Black Anodized)

A: [FBM-1012-BLK Mounting System](#)
B: [AR-2101-BLK 84" Side Rail Feature](#)
C: [AR-2000-BLK 53" Crossbar Feature](#)

[Modular Assembly Manuals](#)

AluRack—Load specifications:

Check vehicle manufacturer recommendations for roof capacity weight limits.

USOV-AR1903-US01 Rev-A 0719

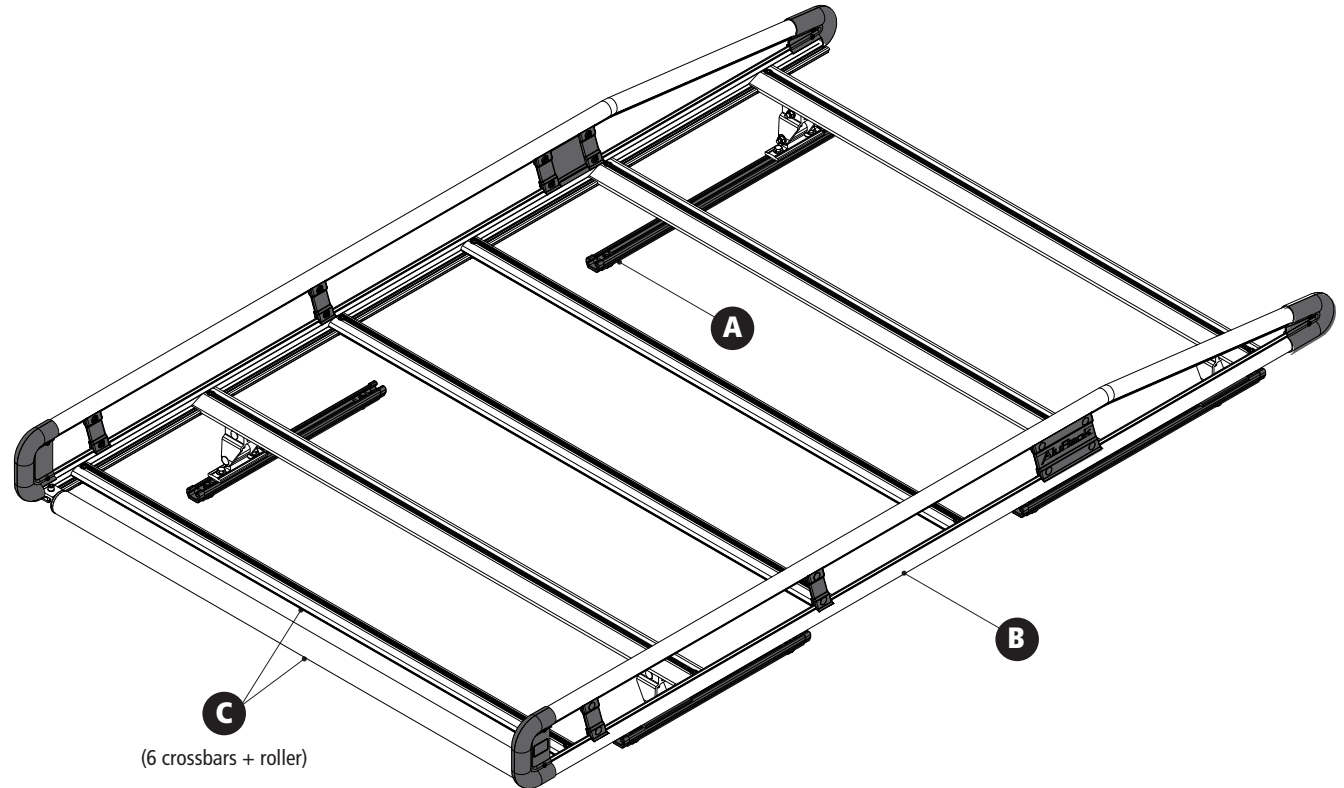

AR1903

Transit Connect L1H1

Approximate dimensions as shown:

- A: Rack Width 55"
- B: Rack Length 88"
- C: Rack Height 10.50"

Compatible Accessories Available (Sold Separately)

- Ladder Clamp Down..... [ACX-AXC Series](#)
- Retractable Ratchet Tie-Down.....[ACC-8000](#)
- 8'–12' Conduit Tubes[CON Series](#)
- WorkPro LED Lighting..... [LED Series](#)
- Systems and Safety Components[RVS Series](#)
- Safety monitoring.....[DS2 Series](#)

