

PRIME DESIGN™

A Safe Fleet Brand

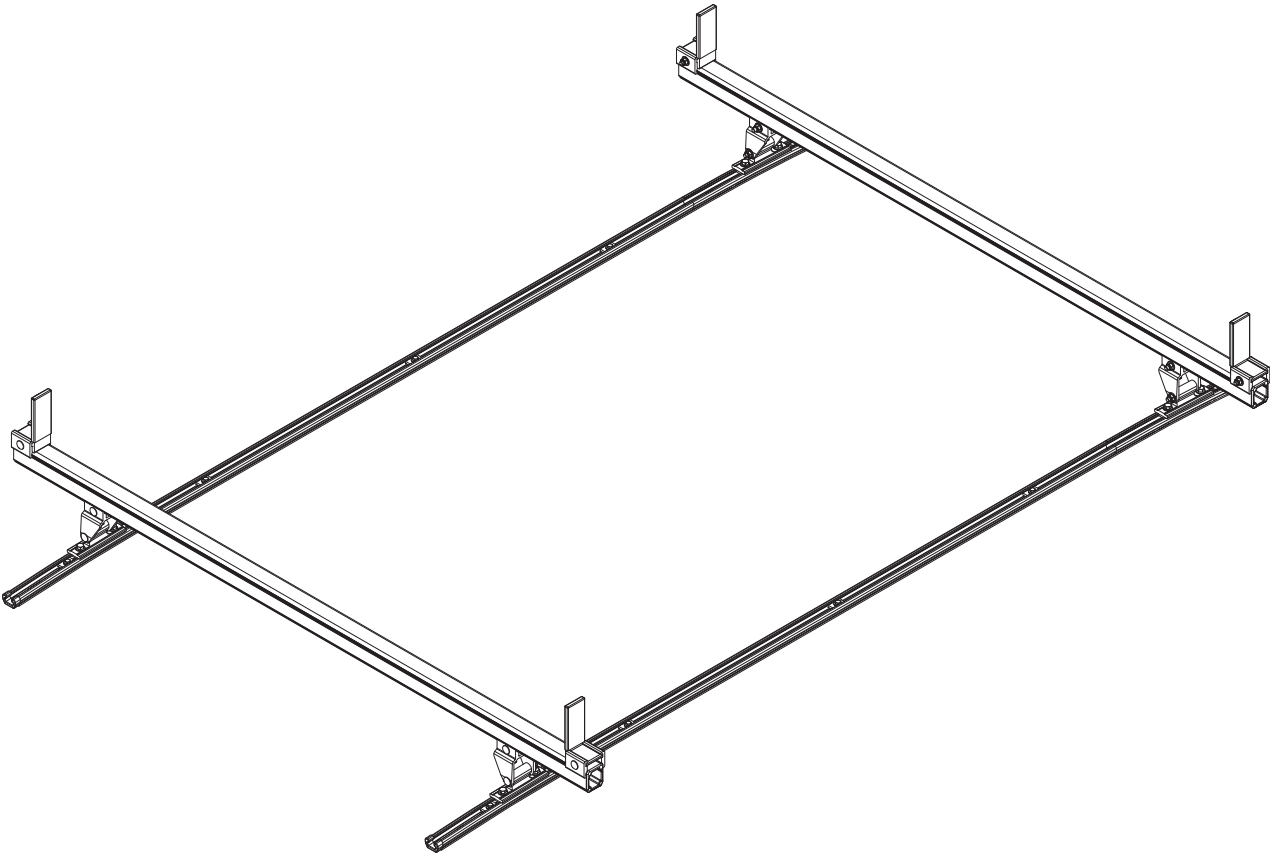

VBB
ROZIB

CONTENTS OVERVIEW

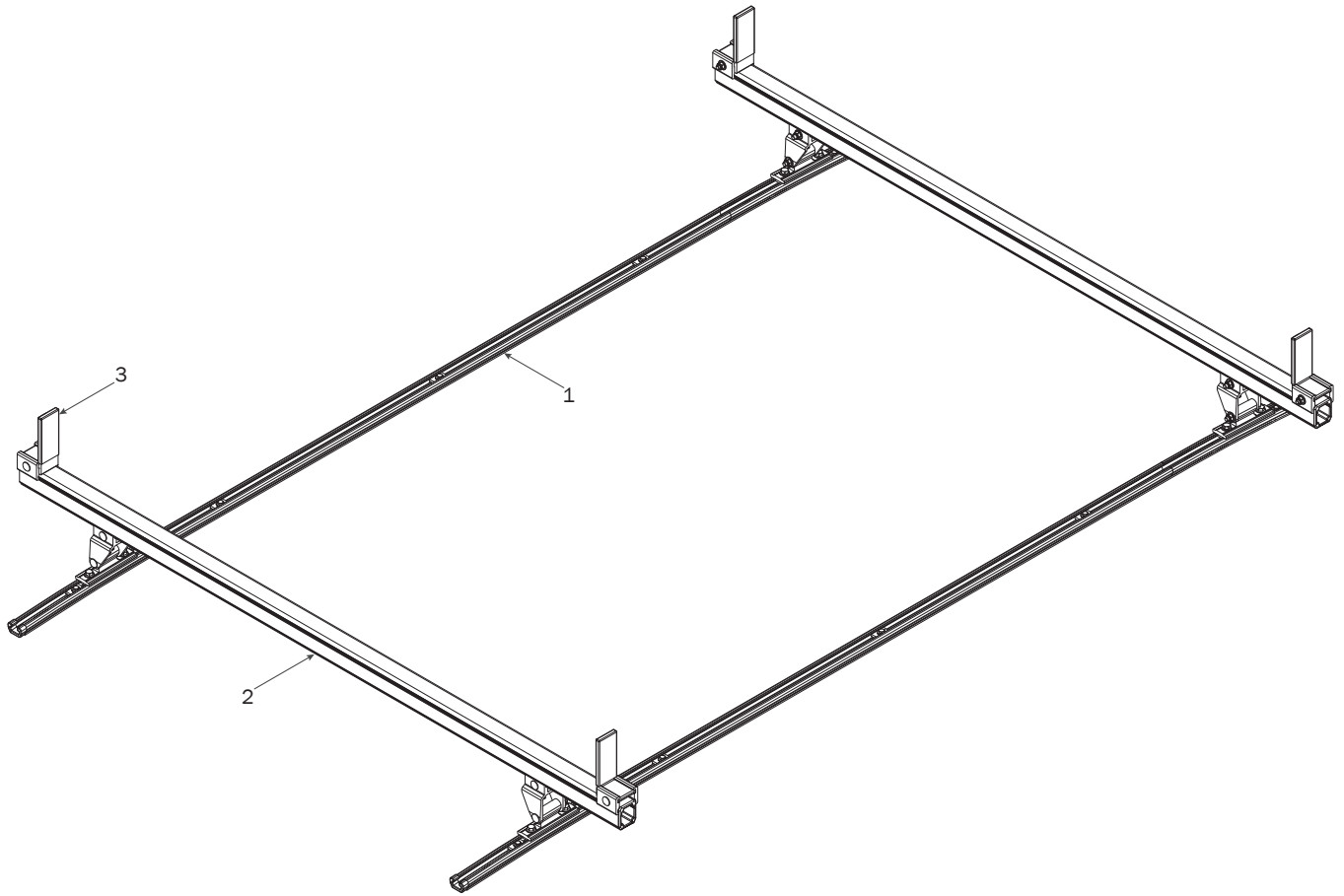

1—FBM-0007 (Qty 1)
Channels with hardware



Channels (2X)



M6 Locknut (10X)



M6 x 30MM Bolt (10X)



End Caps (4X)



Brackets (4X)

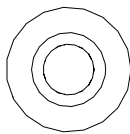

M6 Sealing Washer (10X)

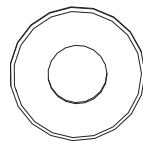

1/4" Flat Washer (10X)

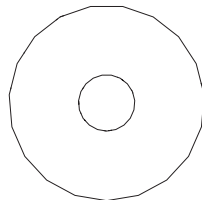

1/4" Washer (10X)

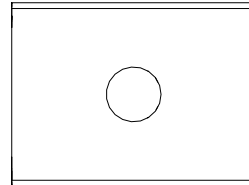

Mounting Plate (10X)

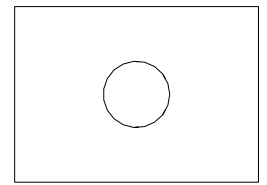

Foam Pad (10X)

2—Crossbar Assembly..... (Qty 2)

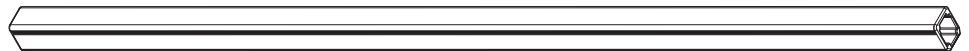

3—Ladder Stop Assembly (Qty 4)
1.75"

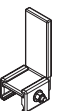

BASE ASSEMBLY

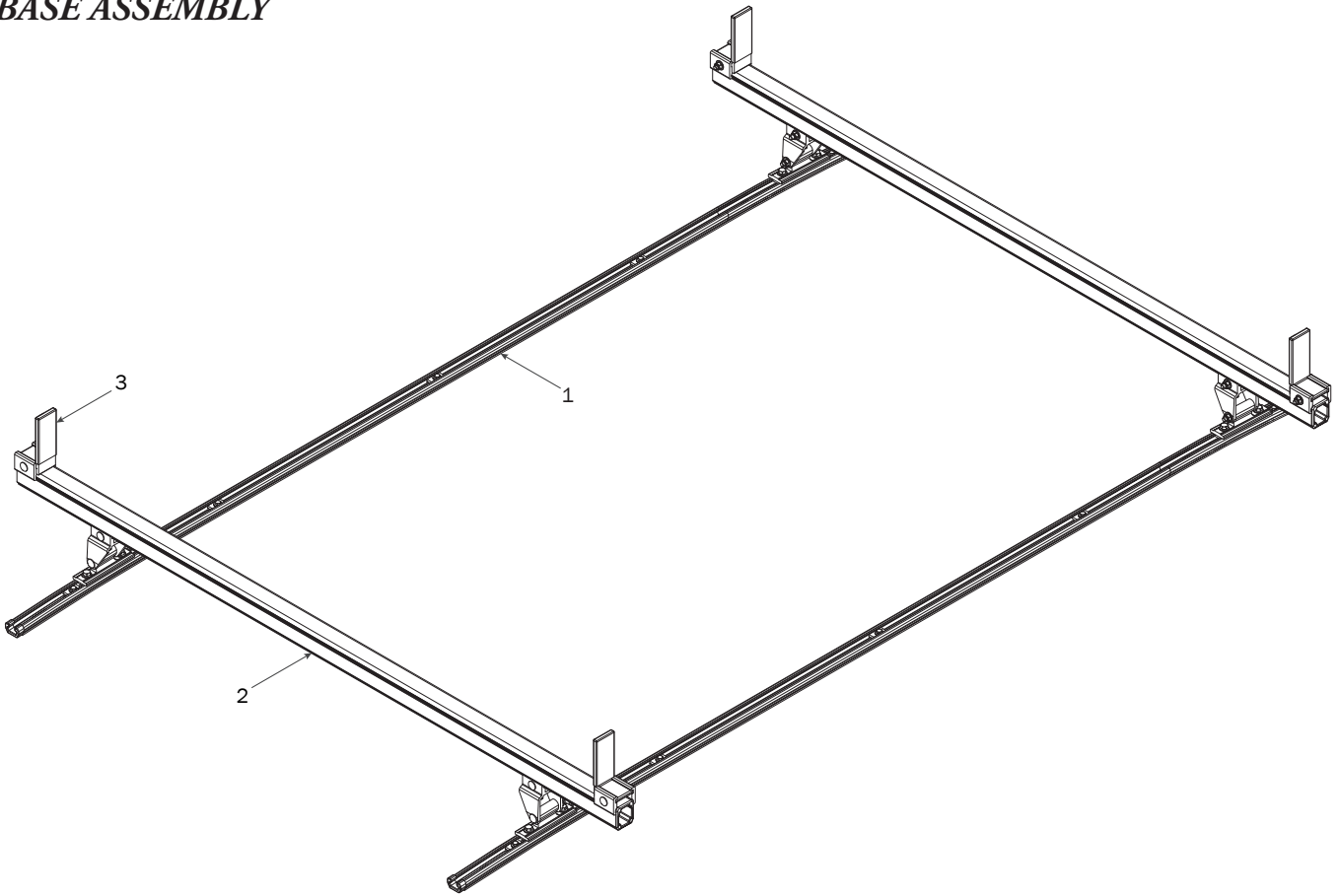

FBM-0007

1.1 Install three sets of Channel Hardware per channel as shown below.

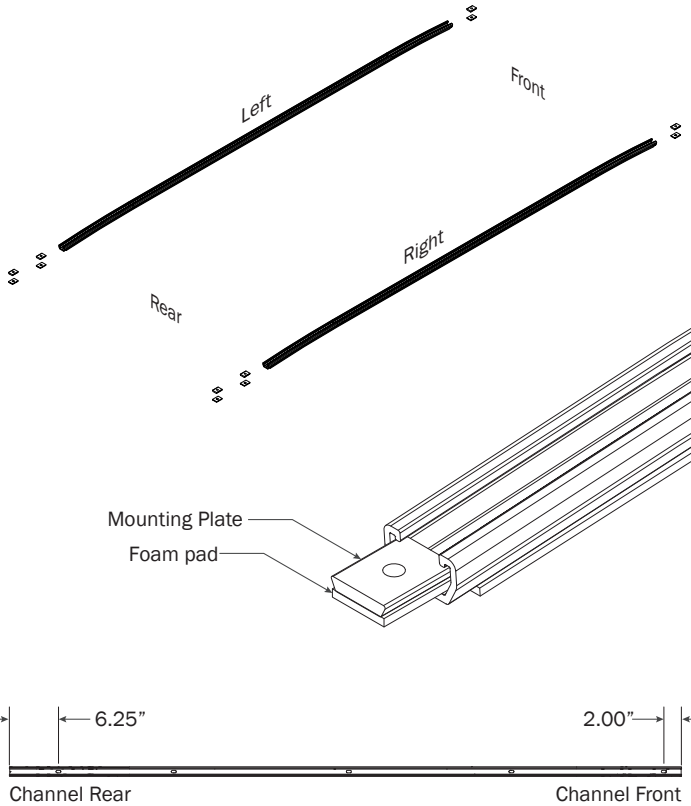

1.2 Install the fasteners through the innermost factory roof holes as shown then torque the nuts to 60 in-lbs.

Do not install or fasten Hardware to the outer front and rear roof holes until Step 1.4.

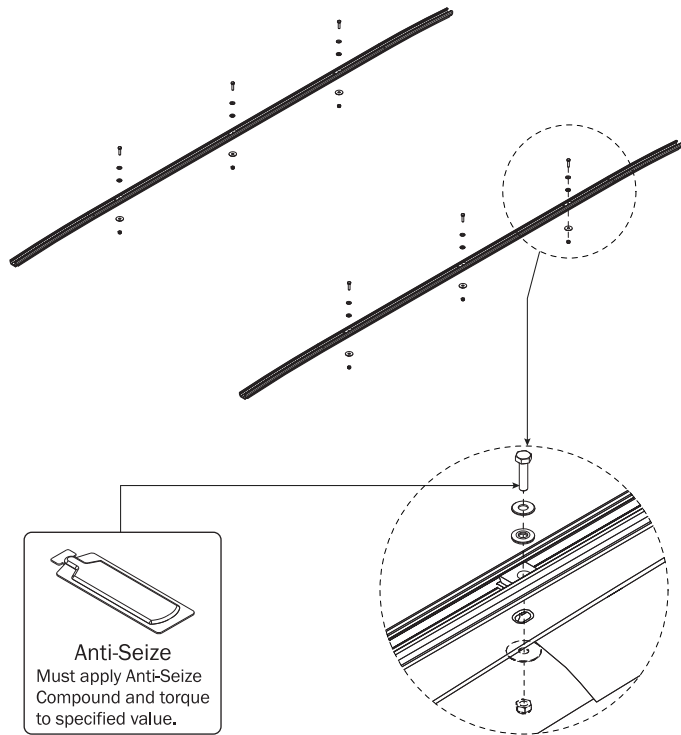

1.3 Install the Mounting Brackets along with the remaining Channel Hardware as shown below.

Do not tighten the Mounting Brackets until Step 1.5.

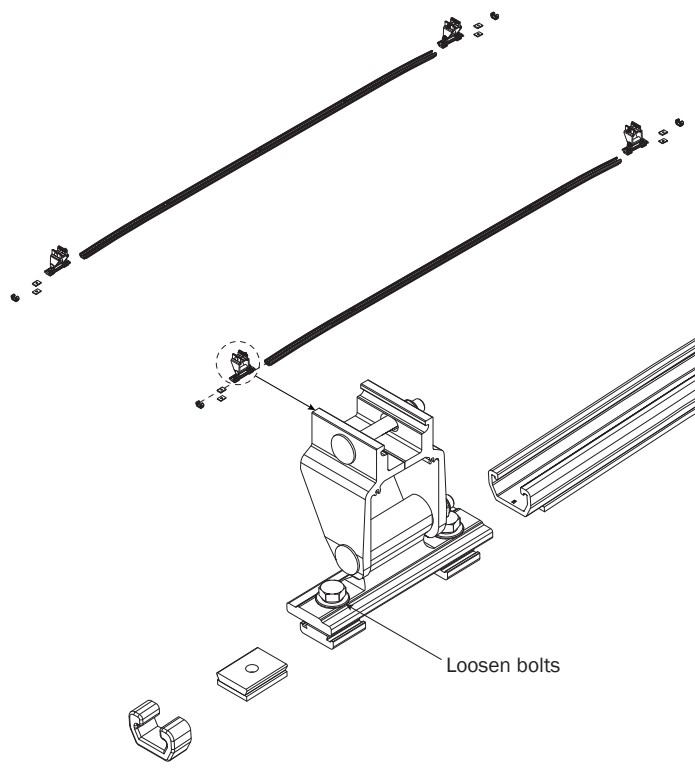

1.4 Install the remaining front and rear fasteners through the factory roof holes as shown then torque the nuts to 60 in-lbs.

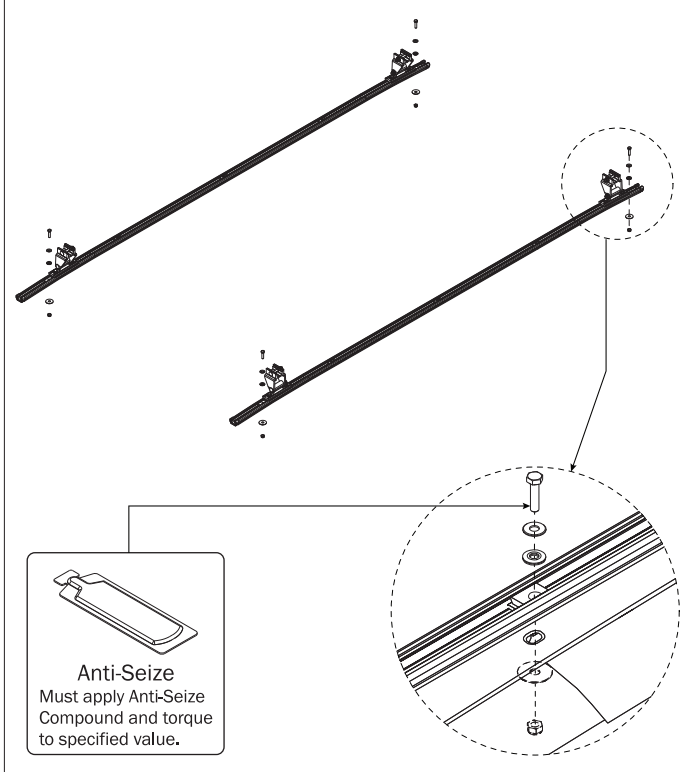

1.5 Set to distances then torque all the Mounting Brackets to 90 in-lbs.

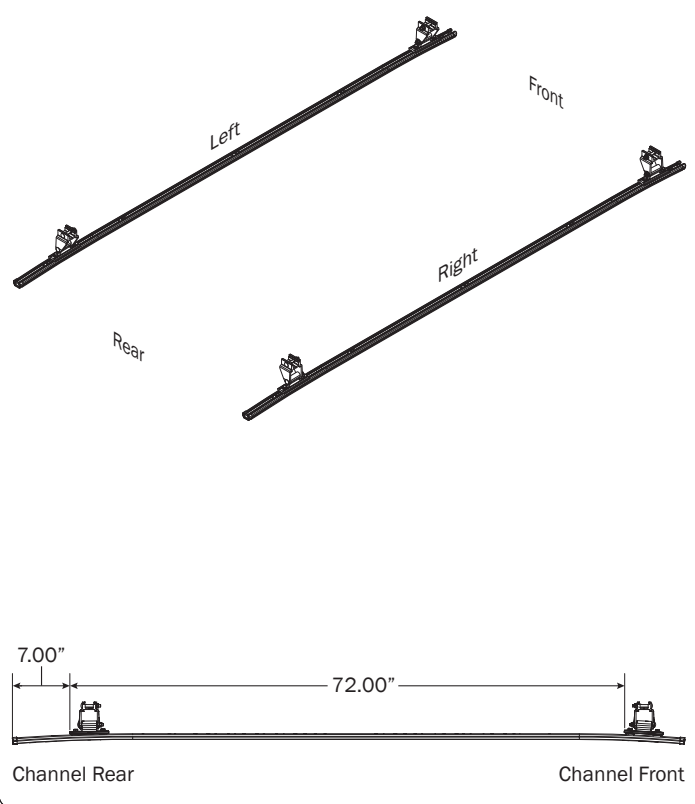

CROSSBARS

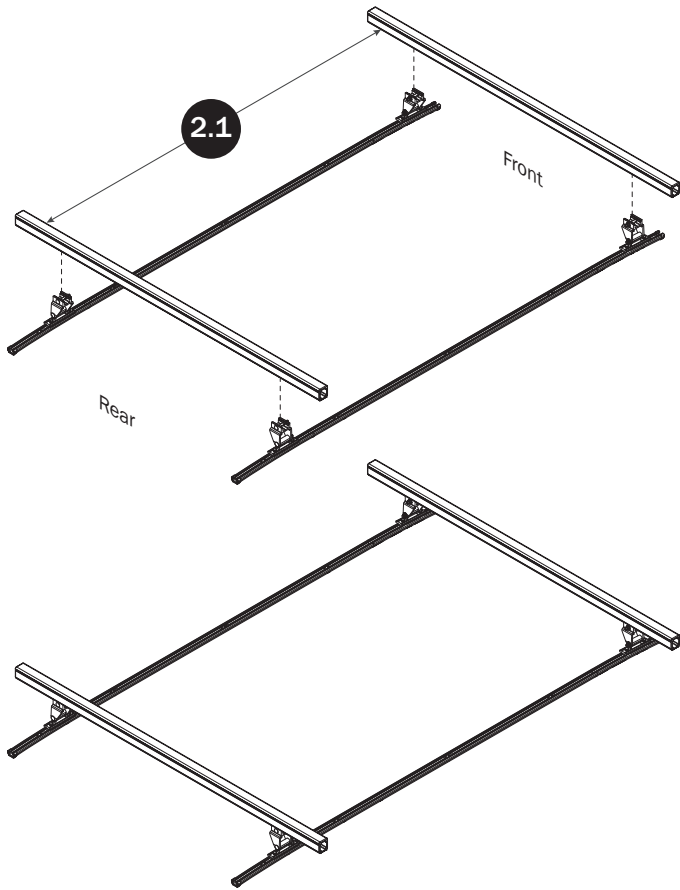

CROSSBAR ADJUSTMENT

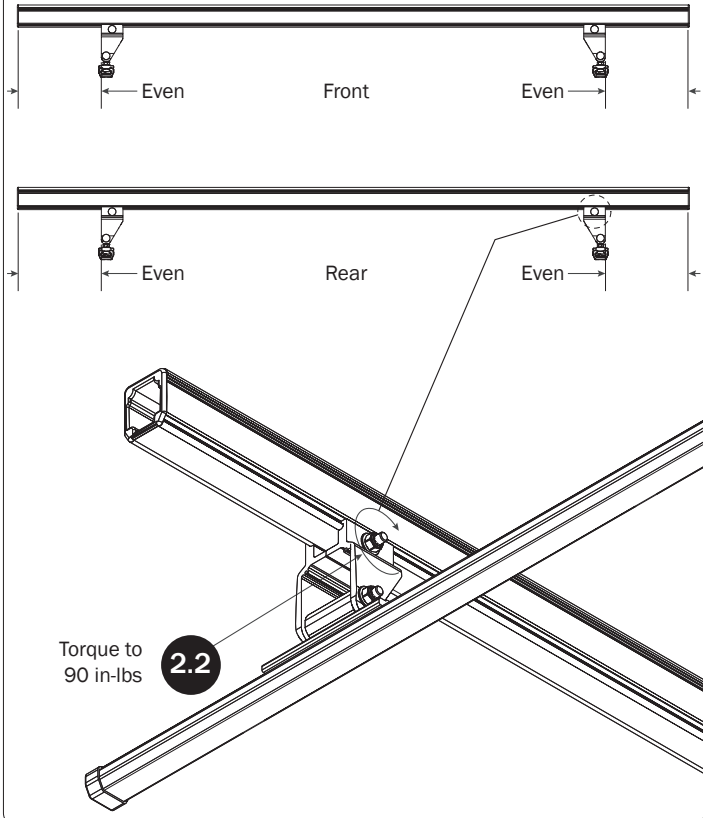

LADDER STOPS

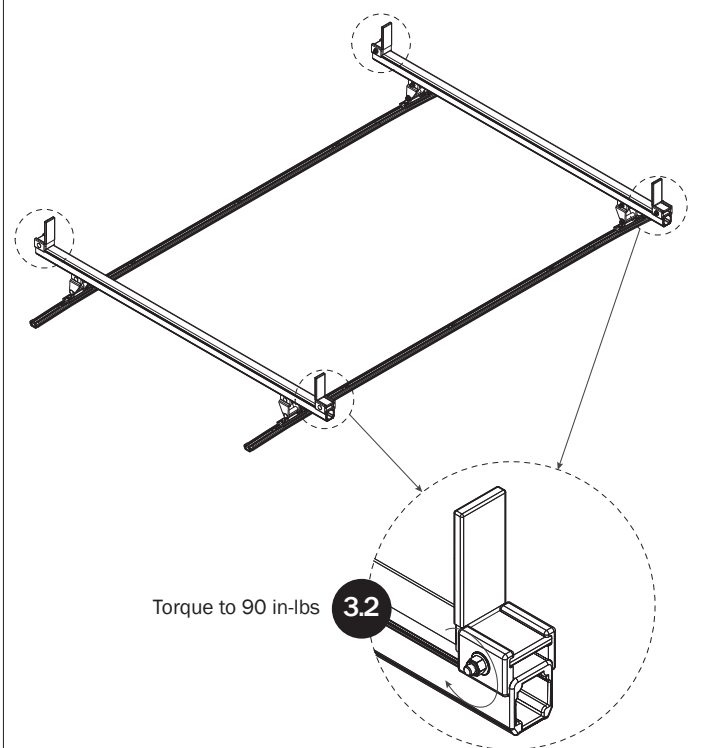
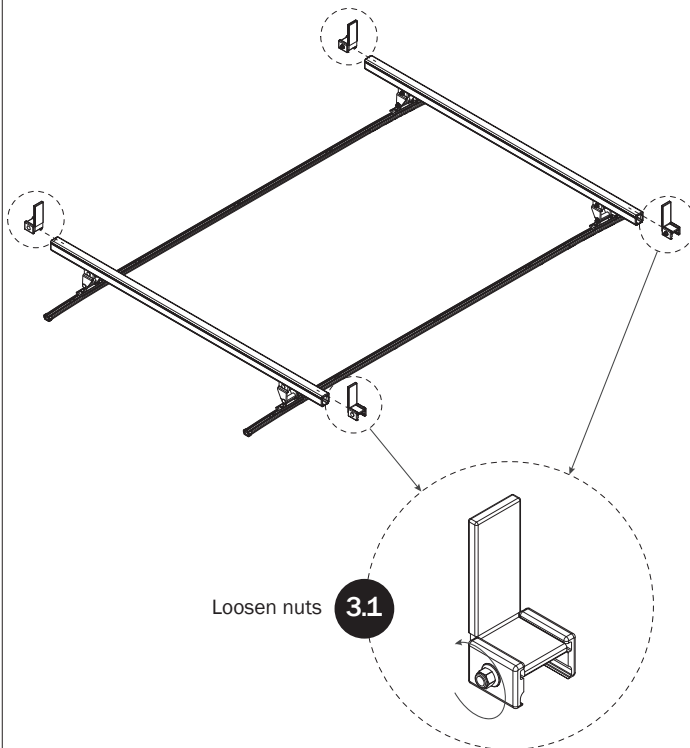

Page Intentionally Left Blank

Page Intentionally Left Blank

