

HBR-E-UM3-M

Utility Direct Mount Series

HBR-E-UM-90-M configuration shown for illustrative purposes

Module Assemblies:

A: End Stop Assembly.....[FEA-0001](#)

B: Mounting System[FBM-1029-BLK](#)

C: Crossbar Assembly Sizes per Rack Configuration:
HBR-E-UM3-72-M:..... [CBR-0007](#)
HBR-E-UM3-78-M:..... [CBR-0005](#)
HBR-E-UM3-84-M:..... [CBR-0016](#)
HBR-E-UM3-90-M:..... [CBR-0018](#)
HBR-E-UM3-99-M:..... [CBR-0020](#)

D: Slide Rotation Assembly (RH).....[FEA-0003](#)

E: Rotation Drive Shaft Assembly (RH).....[FEA-0019](#)

[Modular Assembly Manuals](#)

*Callouts in this Configuration Overview indicate full module assemblies only. For details on individual parts, please refer to the linked Module Overviews.

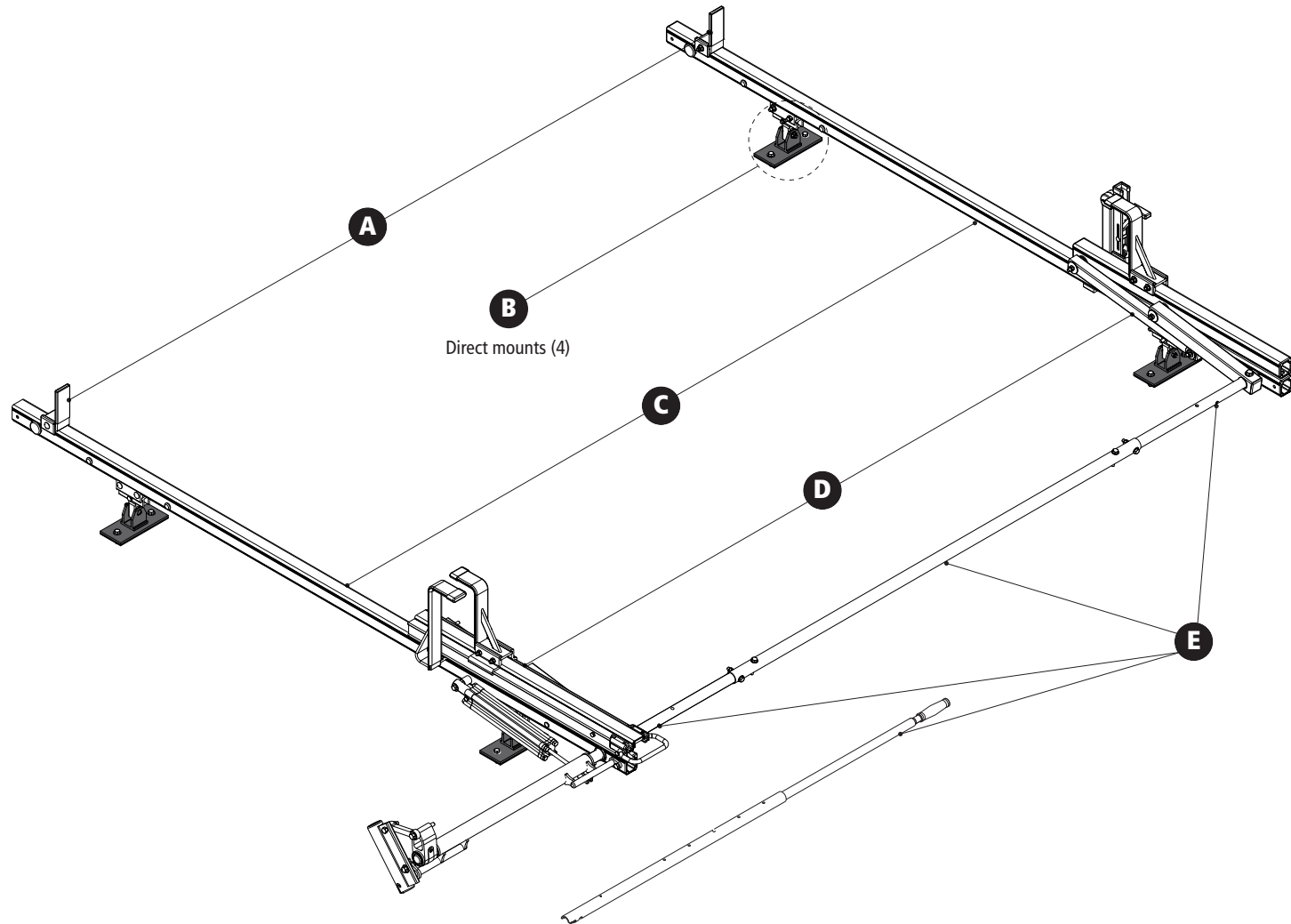

HBR-E-UM3-M

Utility Direct Mount Series

HBR-E-UM-90-M configuration shown for illustrative purposes

Approximate dimensions as shown:

A: Total Rack Widths per Configuration:

HBR-E-UM3-72-M:.....	75"
HBR-E-UM3-78-M:	81"
HBR-E-UM3-84-M:	87"
HBR-E-UM3-90-M:.....	93"
HBR-E-UM3-99-M:	102"

B: Rack Height 18"

C: Crossbar Spacing 6'–8'

D: Rack Length..... 105" – 129"

Compatible Accessories Available

(Sold Separately)

Retractable Ratchet Tie-Down.....[ACC-8000](#)

Conduit Carriers.....[CON Series](#)

WorkPro LED Lighting.....[LED Series](#)

Systems and Safety Components[RVS Series](#)

Safety monitoring.....[DS2 Series](#)

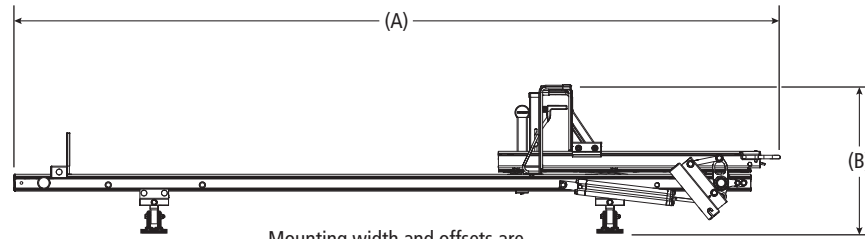

Mounting width and offsets are determined by Vehicle Specifications

