

PRIME DESIGN™

A Safe Fleet Brand

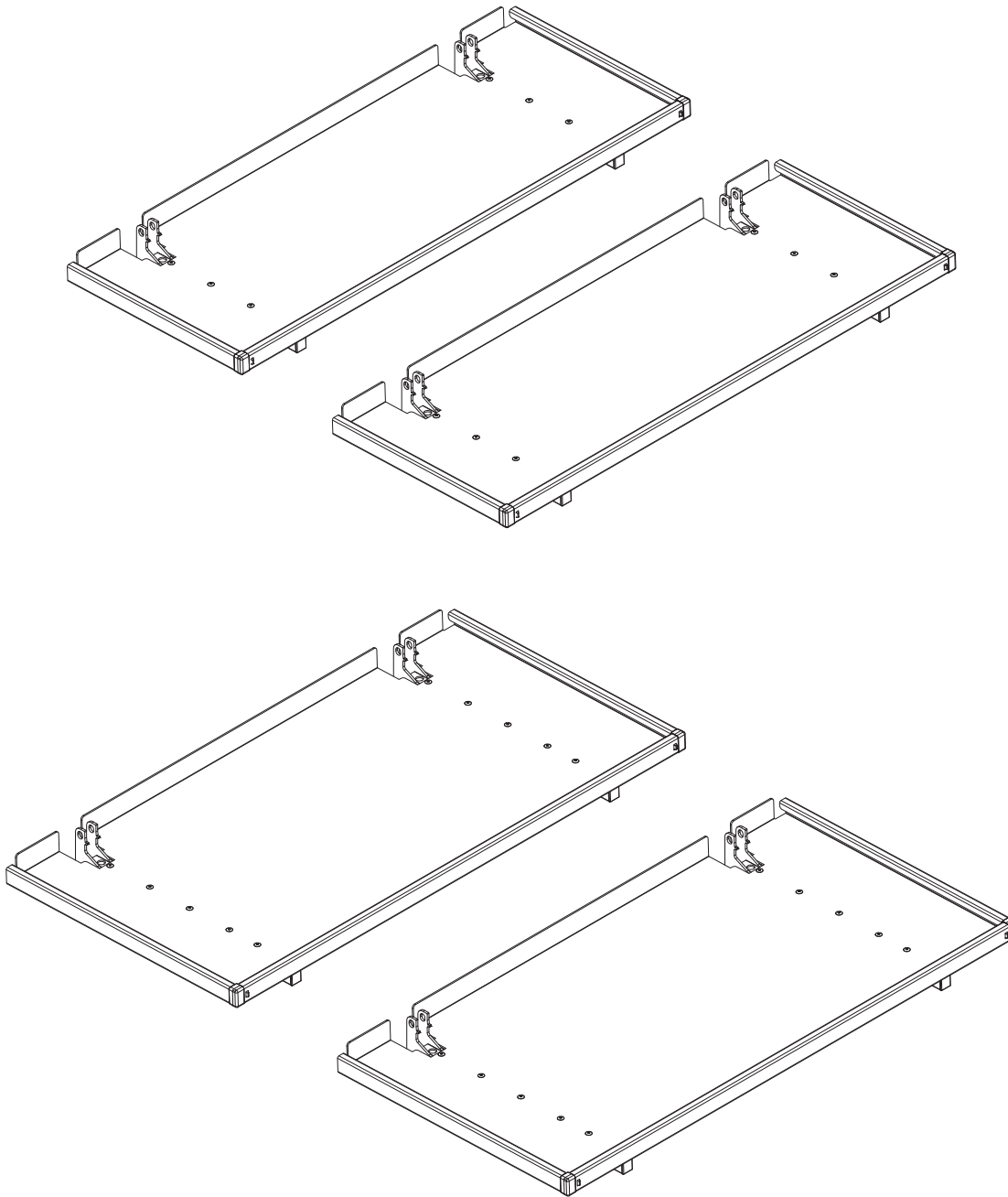

Prime Design FoldPro Shelf Pairs

Page 2-3	18" Shelf Pairs-Packaging Contents and Configurations
Page 4-6	20" Shelf Pairs-Packaging Contents and Configurations
Page 7-8	24" Shelf Pairs-Packaging Contents and
Page 9	Configurations Instruction Sets

PRIME DESIGN, A SAFE FLEET BRAND

Address: 580 Opperman Drive, Eagan, MN 55123 • Toll Free: 1.8.PRIME.RACK
Fax: 651-552-1799 • Email: info@primedesign.net • Website: www.primedesign.net

FPS-5200 SERIES

18.00" DEEP SHELVING PAIR CONTENT OVERVIEWS

NOTE: FoldPro shelf pairs are packaged fully assembled.

FPS-5208—72" x 18" Shelf Pair

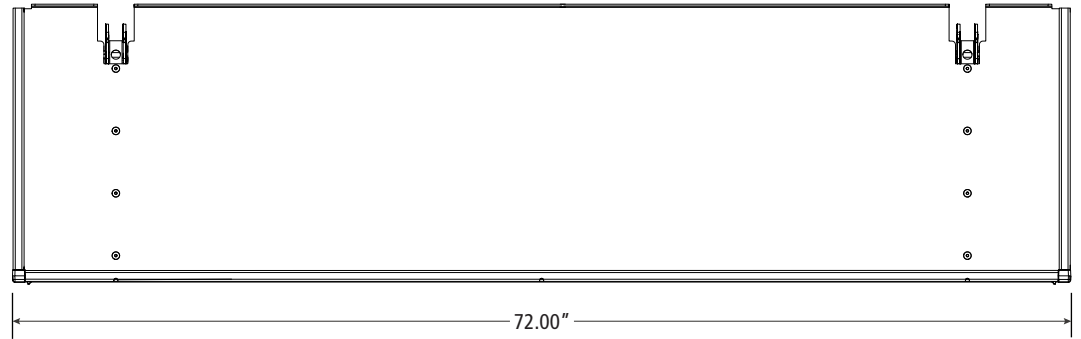

FPS-5207—60" x 18" Shelf Pair

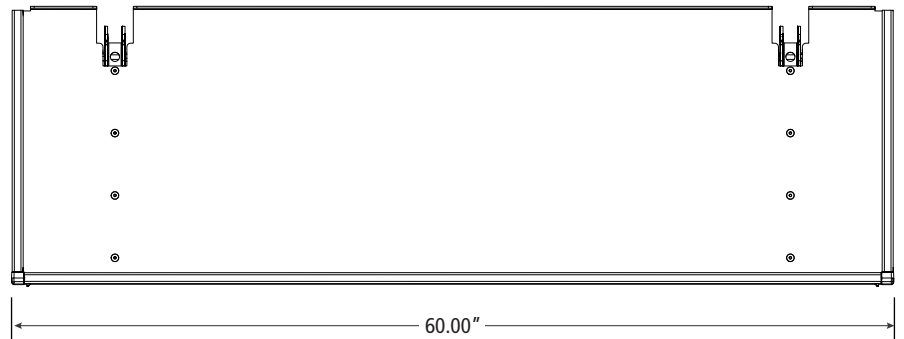

FPS-5206-48" x 18" Shelf Pair

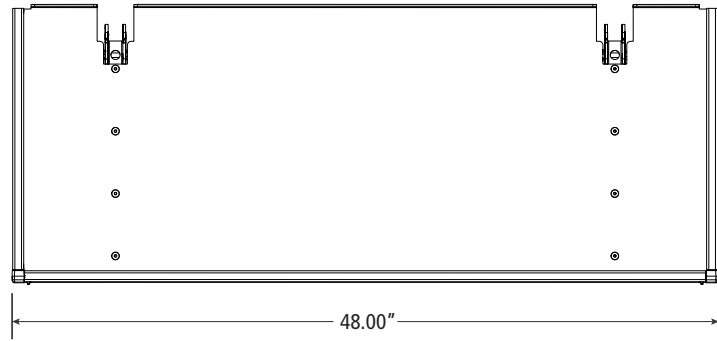

FPS-5205-36" x 18" Shelf Pair

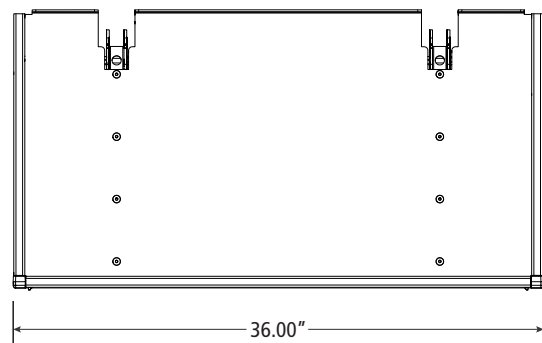

20.00" DEEP SHELVING PAIR CONTENT OVERVIEWS

NOTE: FoldPro shelf pairs are packaged fully assembled.

FPS-5212-72" x 20" Shelf Pair

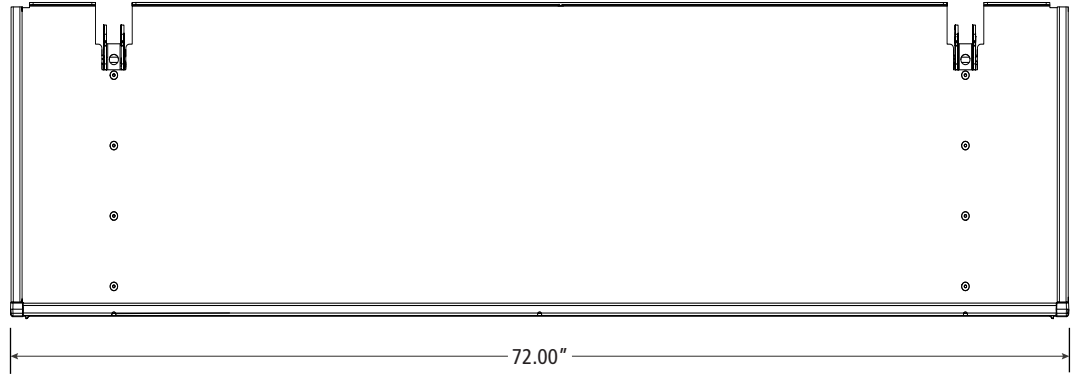

FPS-5211-60" x 20" Shelf Pair

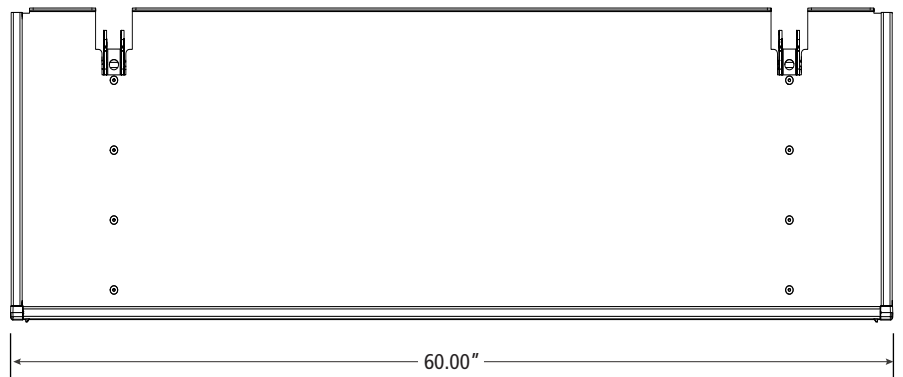

FPS-5210-48" x 20" Shelf Pair

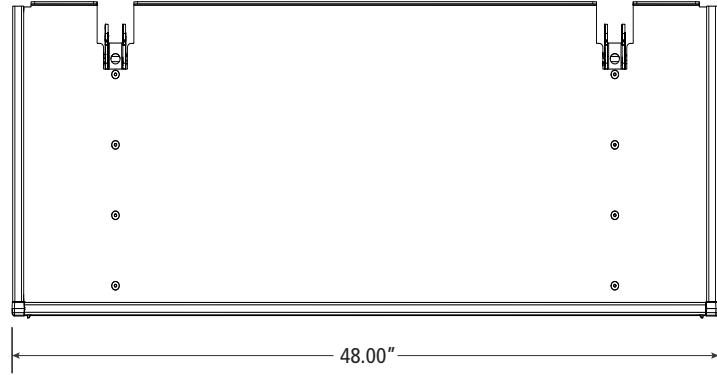

FPS-5209-36" x 20" Shelf Pair

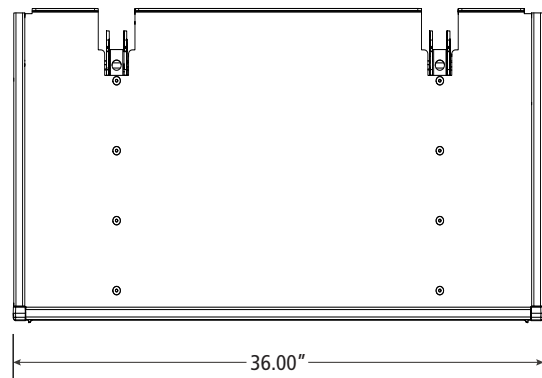

24.00" DEEP SHELVING PAIR CONTENT OVERVIEWS

NOTE: FoldPro shelf pairs are packaged fully assembled.

FPS-5204-72" x 24" Shelf Pair

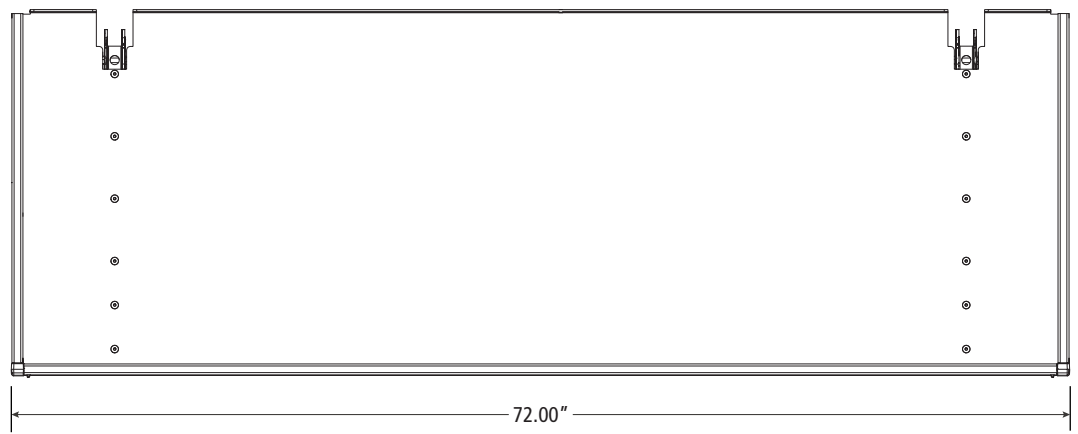

FPS-52003-60" x 24" Shelf Pair

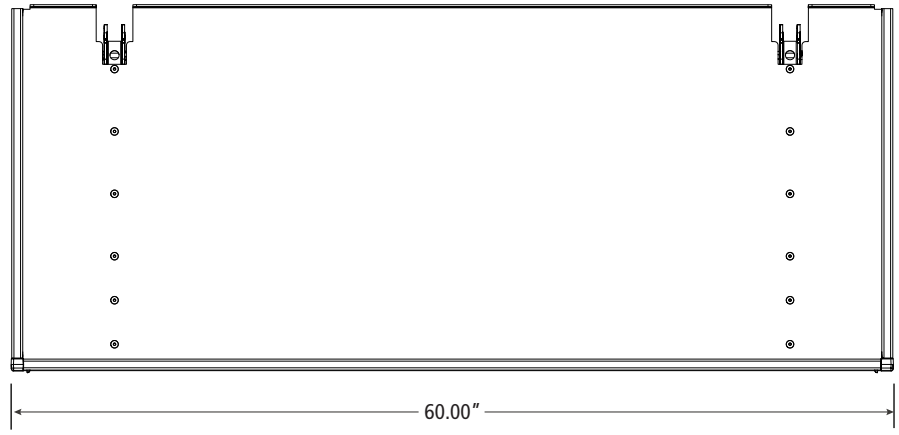

FPS-5202-48" x 24" Shelf Pair

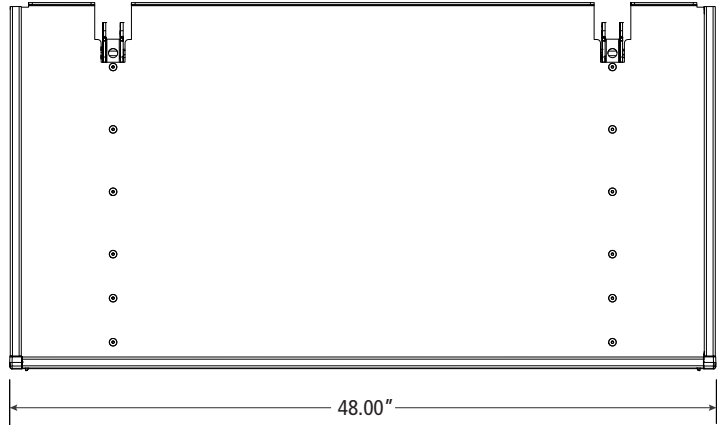

FPS-5201-36" x 24" Shelf Pair

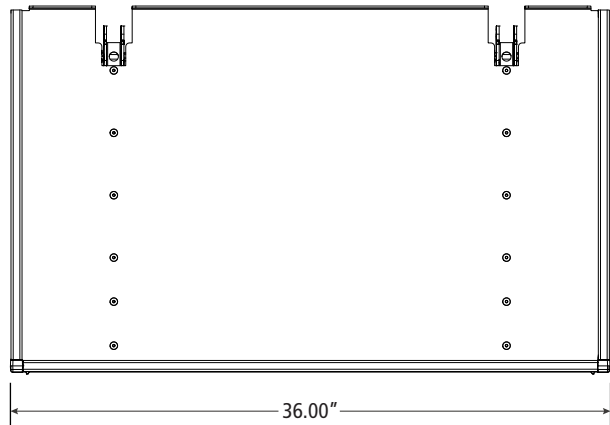



To install FoldPro Shelving, refer to the Upright Shelf Support Assembly Manuals (FPU-3200 Series, or Vehicle-Specific FPU Assemblies) included with your chosen configuration features.

INSTALLER NOTE: To purchase applicable features and accessories, please contact your authorized distributor, or a Prime Design Sales & Service Representative.

