

PRIME DESIGN™

A Safe Fleet Brand

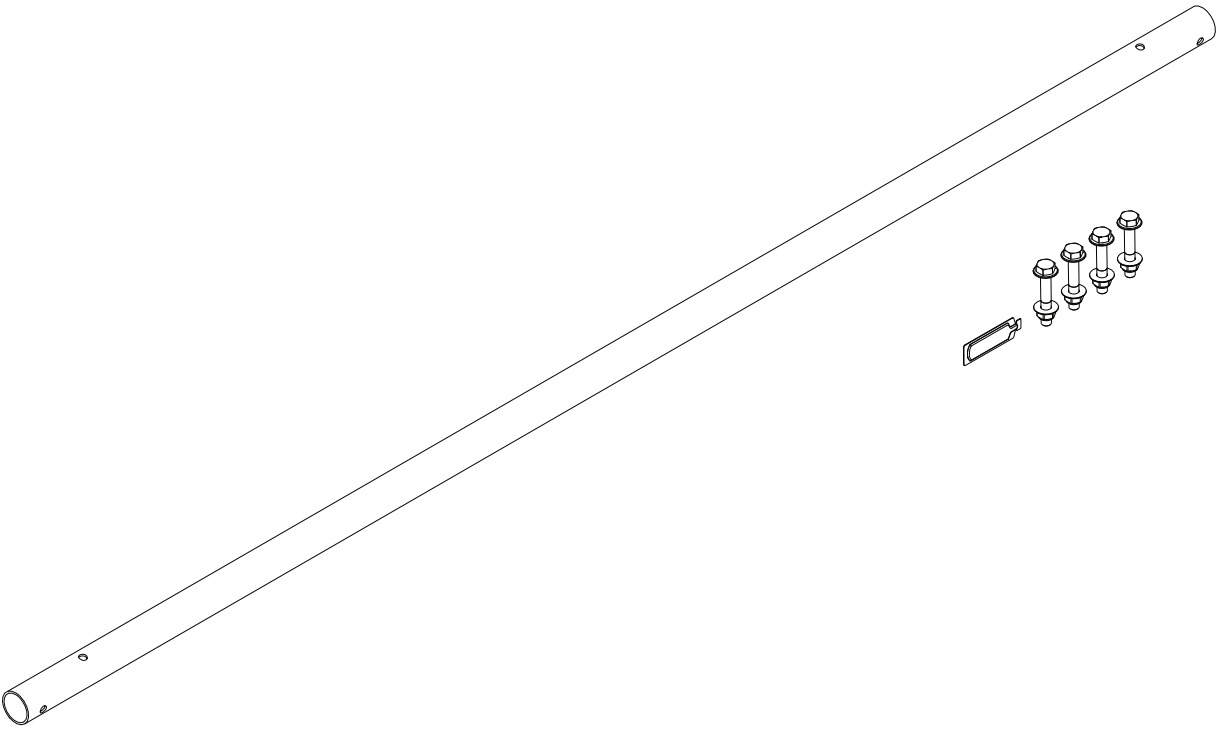

60.00" CONNECTING BAR

PRIME DESIGN, A SAFE FLEET BRAND
Address: 580 Opperman Drive, Eagan, MN 55123 • Toll Free: 1.8.PRIME.RACK
Fax: 651-552-1799 • Email: info@primedesign.net • Website: www.primedesign.net



CONTENTS OVERVIEW

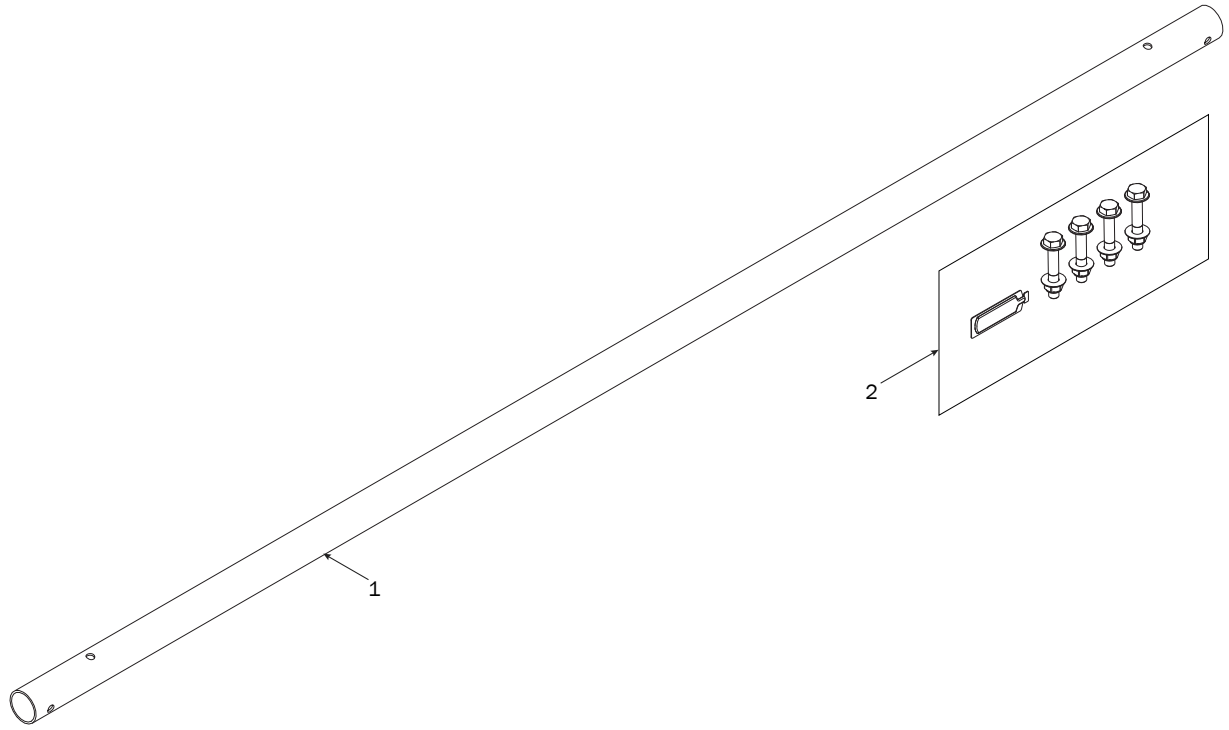

1—Connecting Bar (Qty 1)
60.00"

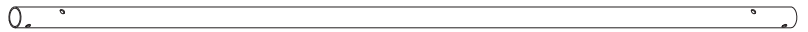

2—HKT-8404 (Qty 1)
Connecting Bar Feature Hardware Kit

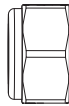

Lock Nut (4X)

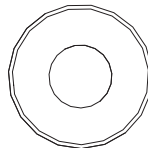

Flat Washer (8X)

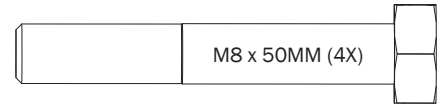

CONNECTING BAR VARIATIONS

Distance D	Connect A to:	Connect B to:
6 ft (72")	A2	B2
7 ft (84")	A1	B2
8 ft (96")	A1	B1

NOTE: Connecting Bar is shown with the RH Rotation features for illustrative purposes only. These features are not included with this Connecting Bar Kit, and must be purchased separately.

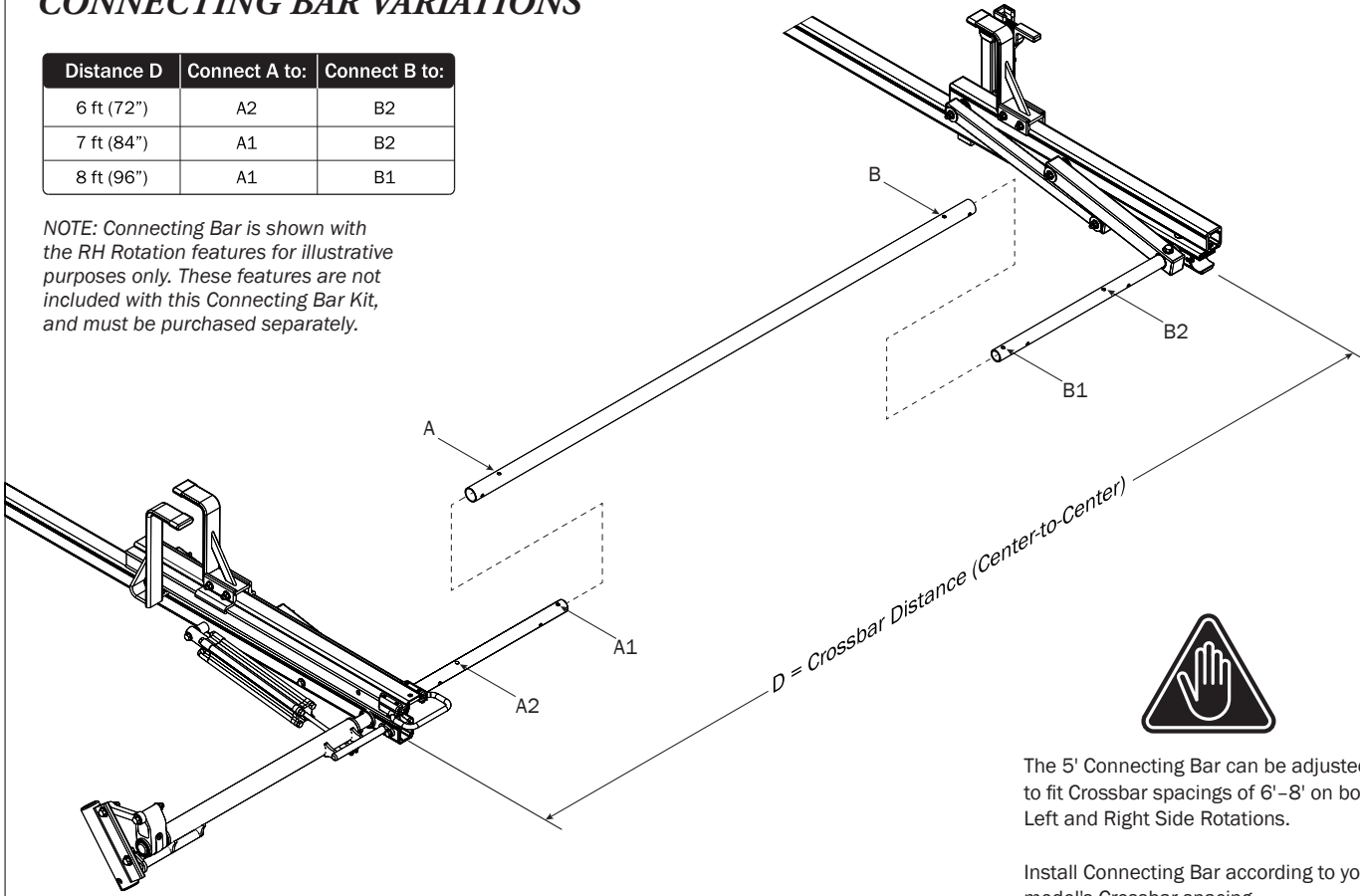

The 5' Connecting Bar can be adjusted to fit Crossbar spacings of 6'-8' on both Left and Right Side Rotations.

Install Connecting Bar according to your model's Crossbar spacing.

CONNECTING BAR

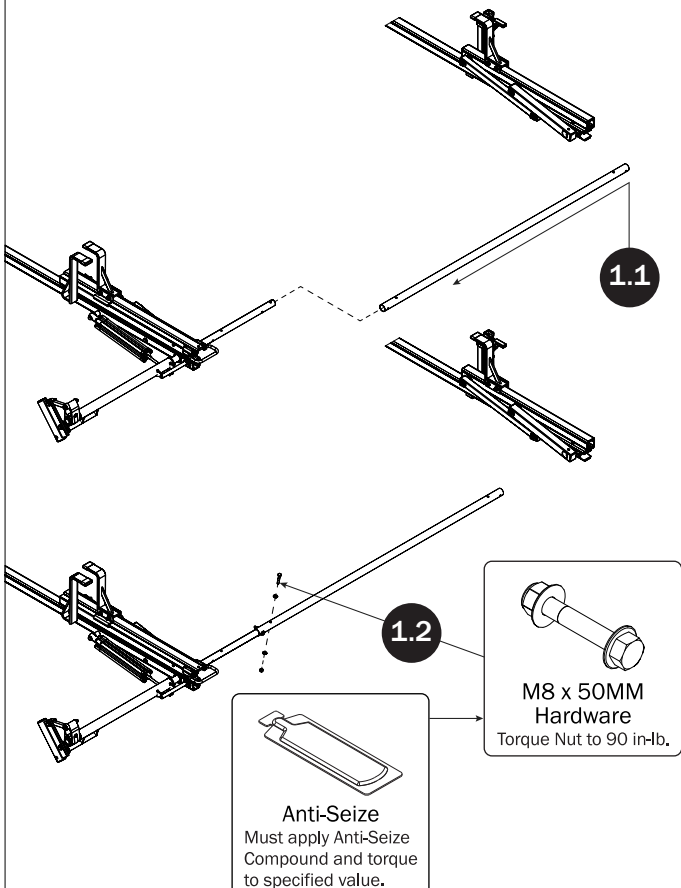

FRONT DRIVE SHAFT

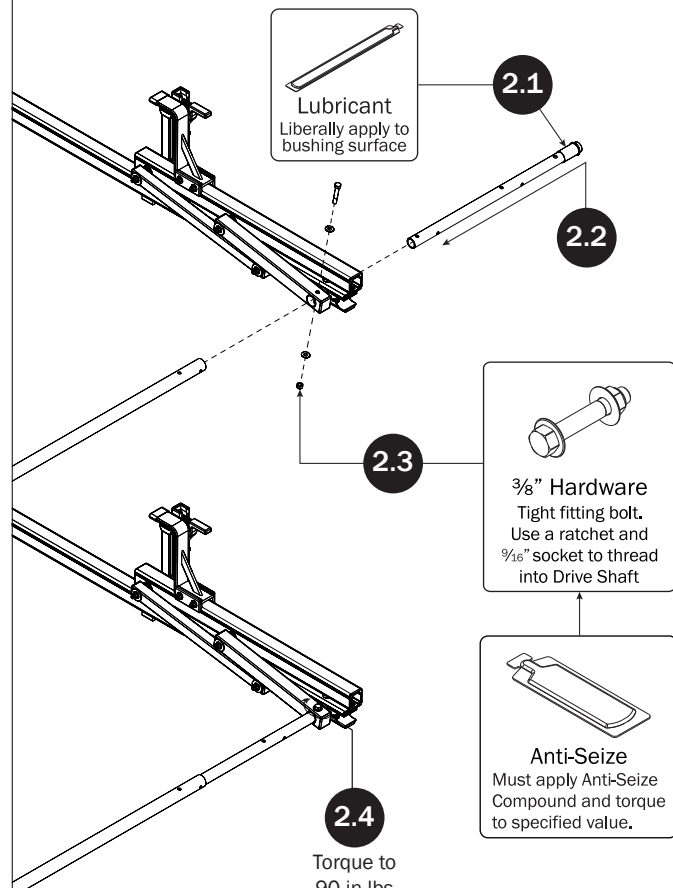

CONNECTING BAR FASTENERS

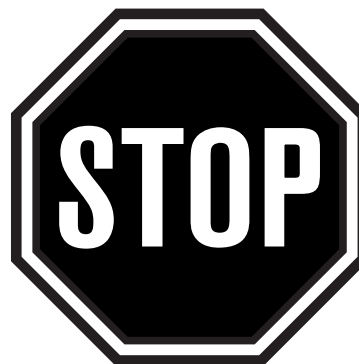
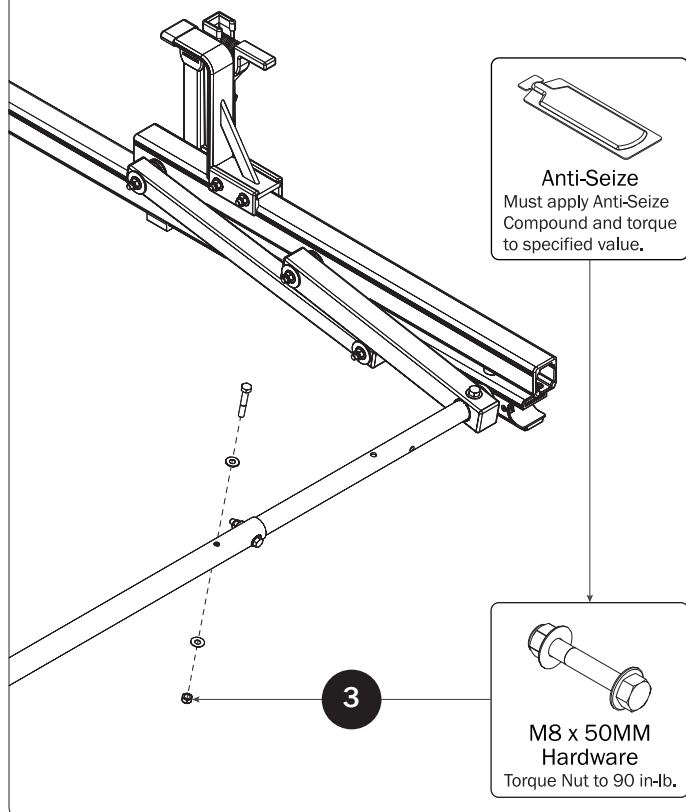

NOTE: This completes the assembling of FEA-0022.

If applicable, refer to your next FEA Assembly Manual.

If completed, refer back to your FBM Assembly Manual, and resume assembling at Step 5.1.

WARNING: Failure to position the Crossbars as shown in your FBM Assembly Manual may result in damage to the sliding door and/or ladder rack.

USAM-FEA0022-US01 Rev-A 0619