

# PRIME DESIGN™

A Safe Fleet Brand

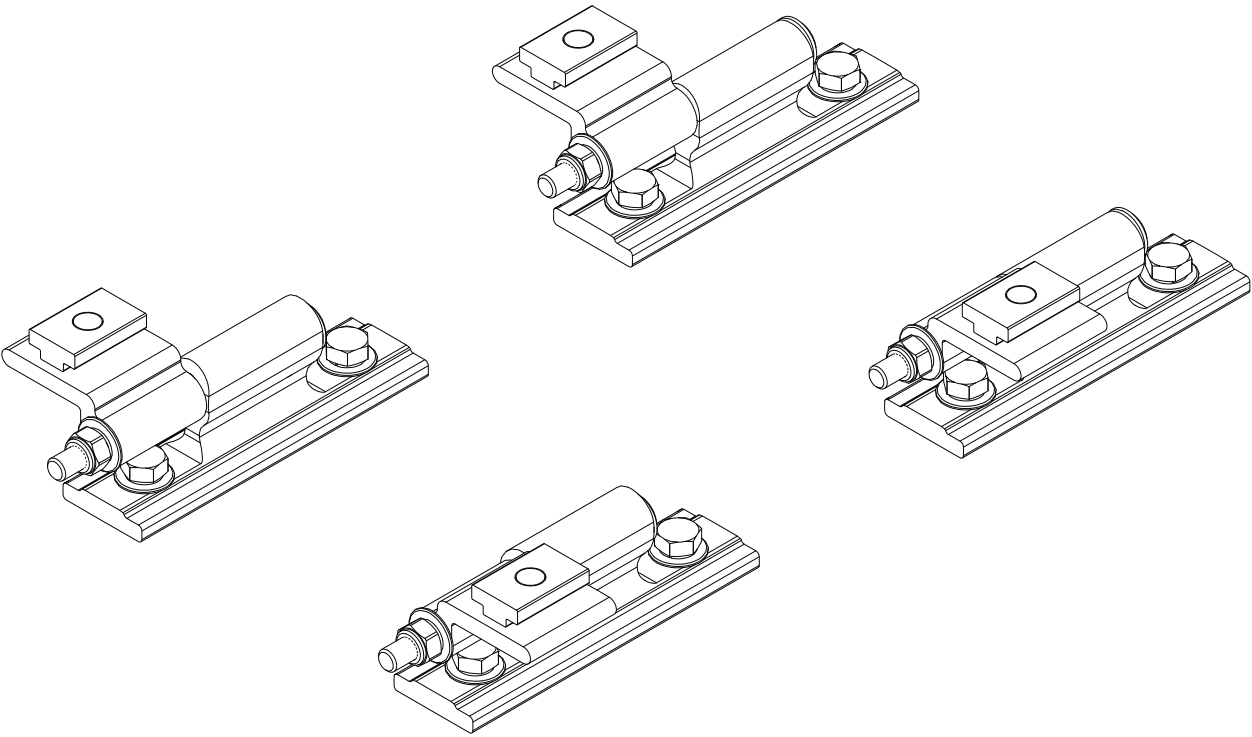

**MPK 8006**

**MPK-8006**

Mounting Brackets shown in position on a generic cap with customer-supplied Channels and Strip Nuts for illustrative purposes only.

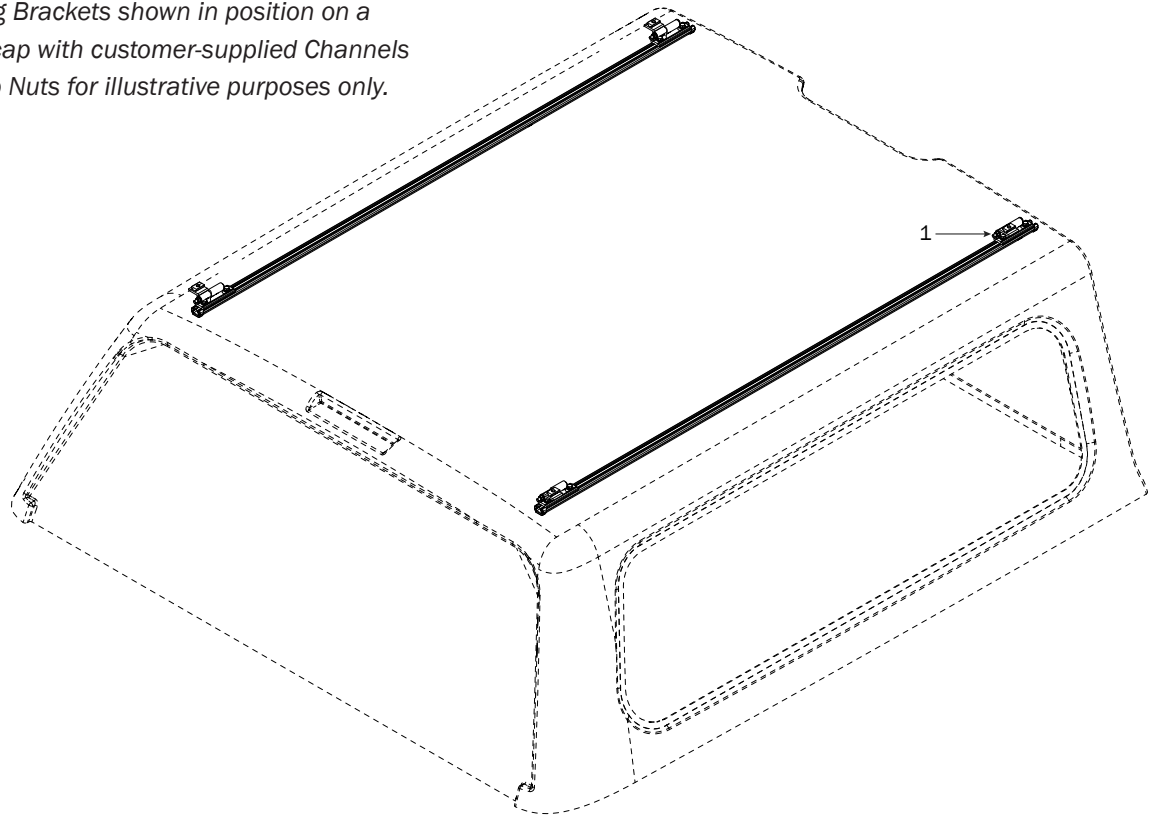

1—Mounting Brackets ..... (Qty 4)

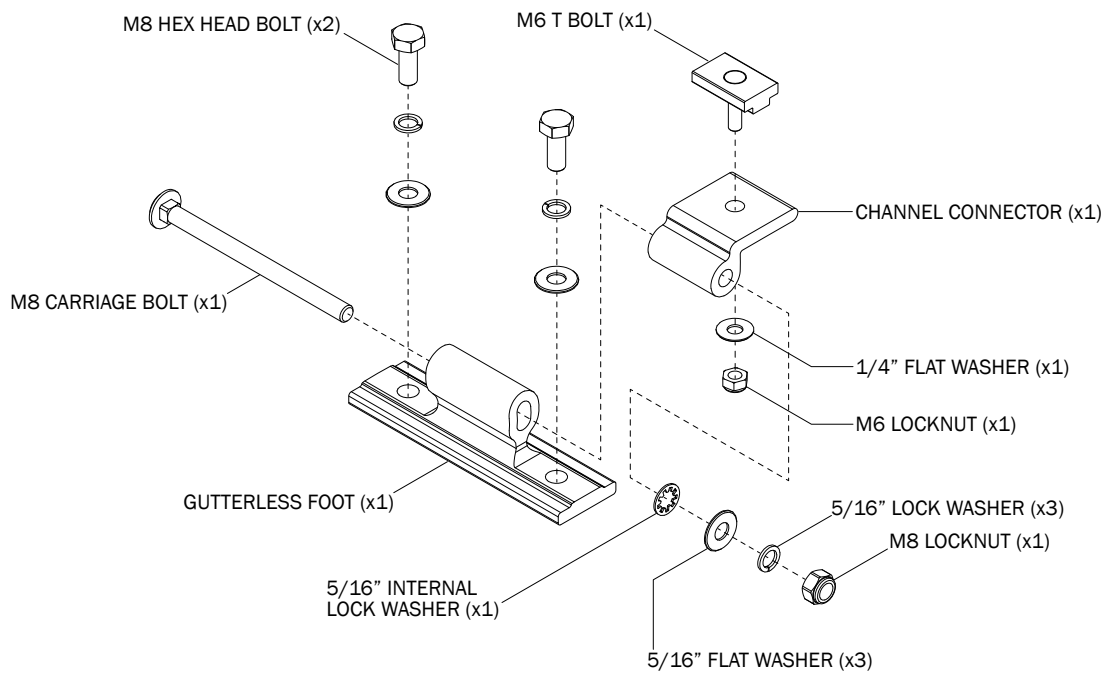

**MPK-8006**  
MOUNTING BRACKETS

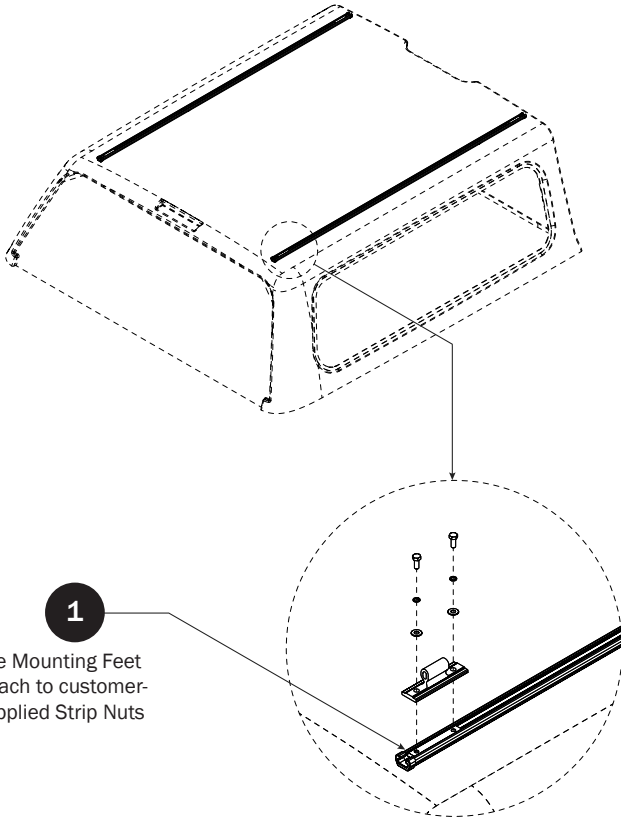

**1**

The Mounting Feet attach to customer-supplied Strip Nuts

**2** Set all mountings onto customer-supplied Channels as shown. Do not tighten until Step 4

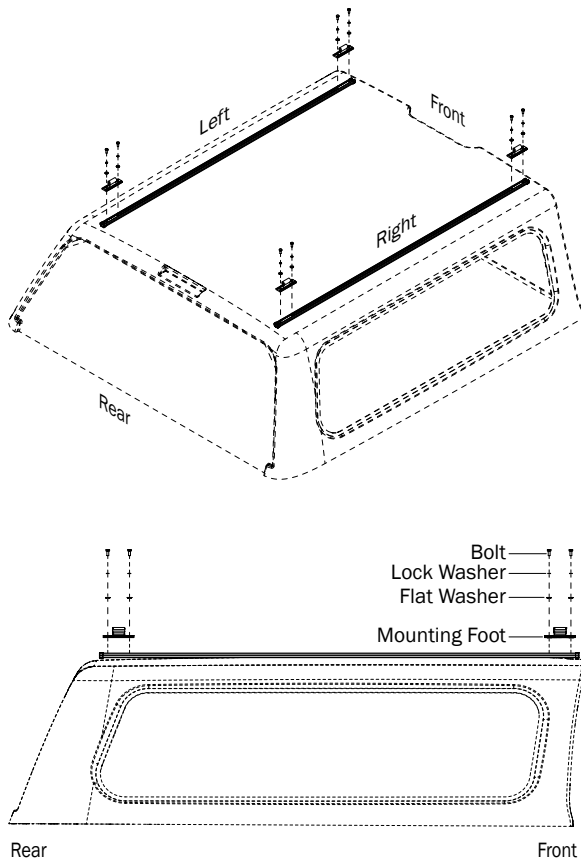

**3** Set Crossbar Mounting distances according to specific Ladder Rack model requirements. Typical distances are between 4' to 8' in 1' increments.

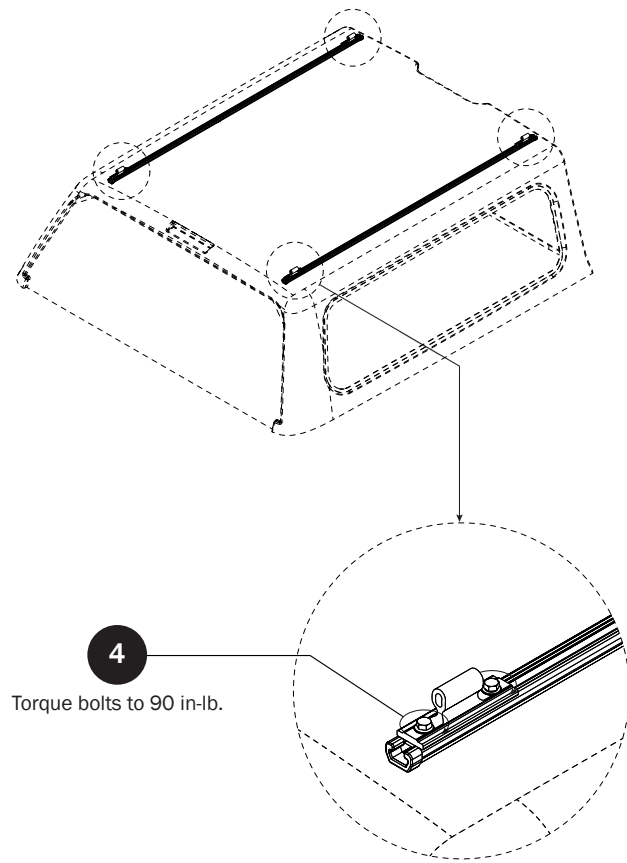
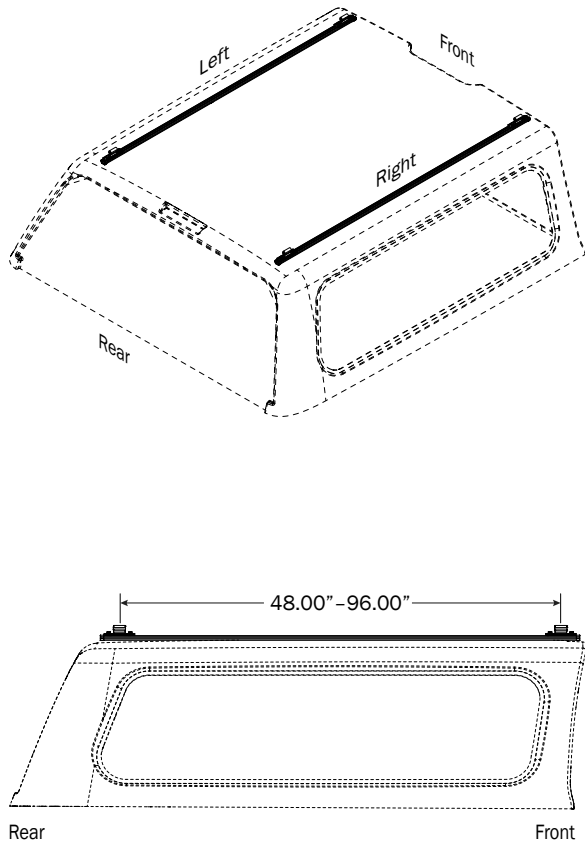

**4**

Torque bolts to 90 in-lb.

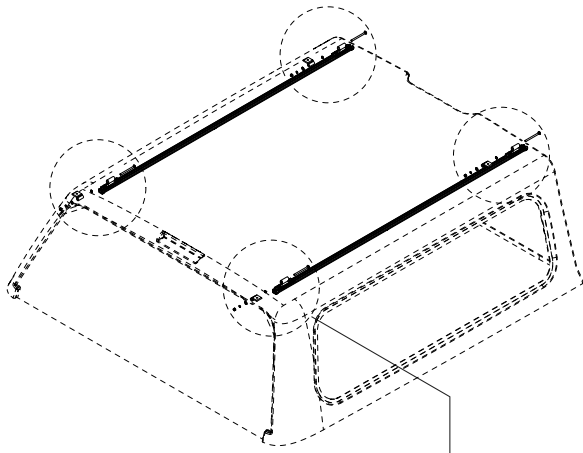

5

Attach the Channel Connector to the Mounting Foot using the supplied 8MM hardware

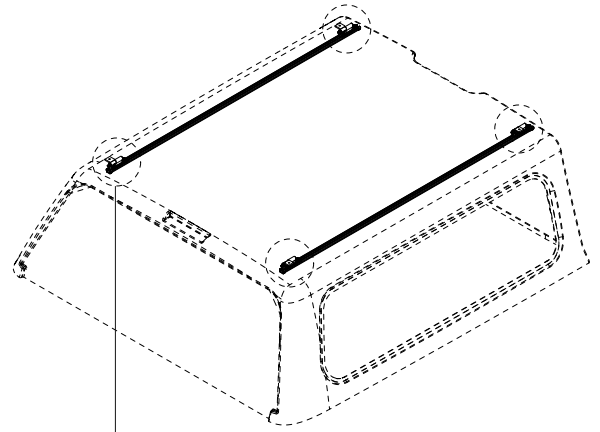
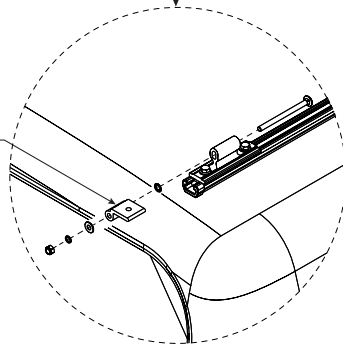

6

Do not tighten the nut until the Stiff Channels and Crossbars have been installed onto the 6MM T Bolt shown in Step 7

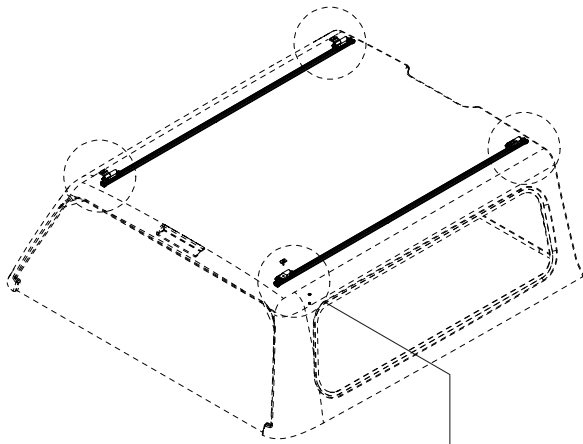
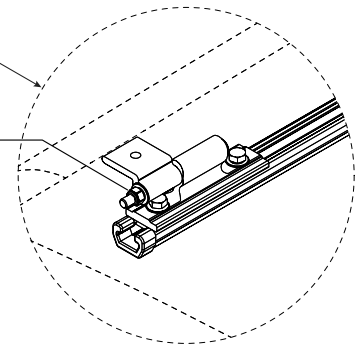

7

Install the T Bolt to the Channel Connector using the supplied 6MM nut and washer. Do not tighten the nut until the Stiff Channels and Crossbars have been installed and adjusted

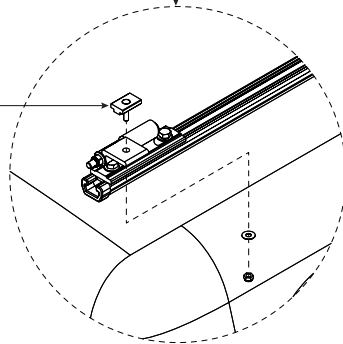

USAM-MPK8006-US01 Rev-A 0116