

VBR-FES-M

ErgoRack, Ford E-Series

Two Crossbars, Powder Coat Finish
Rack Weight (empty): 56 lbs

*Callouts in this Configuration Overview indicate full module assemblies only.

For details on individual parts, please refer to the linked Module Overviews below.

- A: [FEA-0001 Ladder End Stop Assembly](#)
- B: [CBR-0003 Crossbar Assembly](#)
- C: [FEA-0002 Rotation Assembly](#)
- D: [FEA-0022 5' Connecting Bar](#)
- E: [FEA-0015 Rotation Driveshaft Feature](#)
- F: [FBM-1068-BLK Mounting System](#)

[Modular Assembly Manuals](#)

ErgoRack Van—Load specifications:

Check vehicle manufacturer recommendations for roof capacity weight limits.

CROSSBAR SPACING	STEP LADDER	EXT. LADDER
4 ft Spacing	6 – 8 ft.	16 – 20 ft.
5 ft Spacing	8 – 10 ft.	16 – 24 ft.
6 ft Spacing	8 – 12 ft. [†]	16 – 28 ft.
7 ft Spacing	10 – 12 ft. [†]	20 – 32 ft.
8 ft Spacing	10 – 12 ft. [†]	20 – 36 ft.

[†]Rotation Configurations: 12 ft. step ladders require an extended upper add-on component.

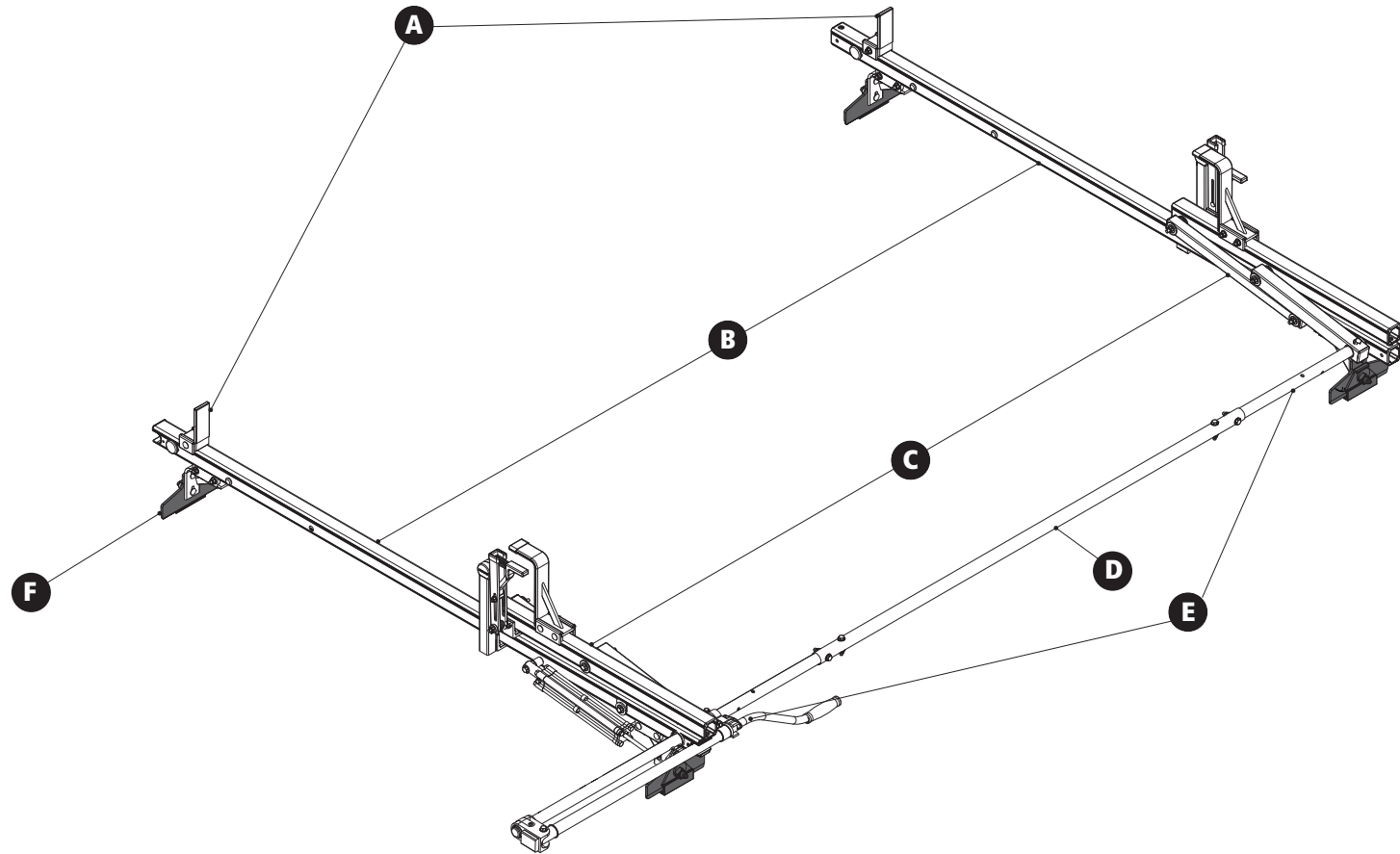

VBR-FES-M

ErgoRack, Ford E-Series

Approximate dimensions as shown:

- A: Rack Width 68"
- B: Rack Height 18"
- C: Rear Crossbar Offset (Left).....Even
- D: Mount Bolt Spacing L/R..... Variable
- E: Total Crossbar Spacing..... 8'
- F: Rack Length 128"

**5' Connecting Bars (sold separately) are required for spacings that exceed 6'—contact Sales & Service.*

- 3' Connecting Bar (Included in current configuration)
- 5' Connecting Bar (Sold separately)

Compatible Accessories Available (Sold Separately)

- 5' Rotation Connecting Bar [FEA-0022](#)
- 8'–12' Conduit Carriers [CON Series](#)
- WorkPro LED Lighting..... [LED Series](#)
- Systems and Safety Components [RVS Series](#)
- Safety monitoring..... [DS2 Series](#)

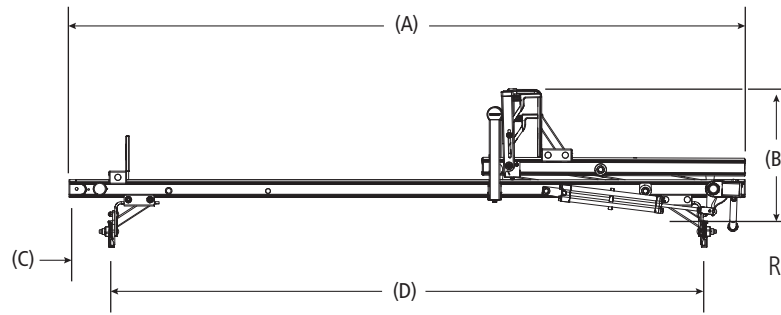

Rear Drive Shaft Offset: 24"

Note: The end of the driveshaft must not extend beyond the vehicle bumper

