

ASH-8127

Strobe/Go-Light Holder

Dimensional Specifications on Page 2

Configuration as shown:

Over The Cab Rack Light Holder

Finish: White Powder Coat

Rack Weight (empty): 1.50 lbs

Crossbar Mounting Configuration

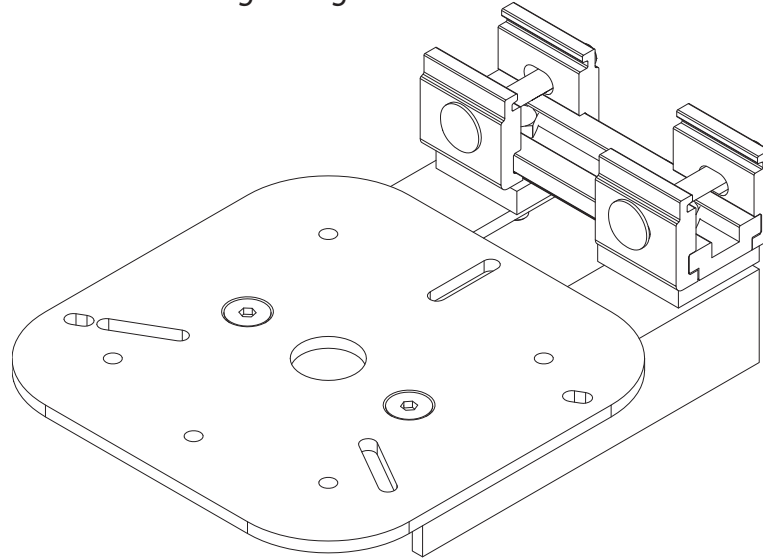

Side Rail Mounting Configuration

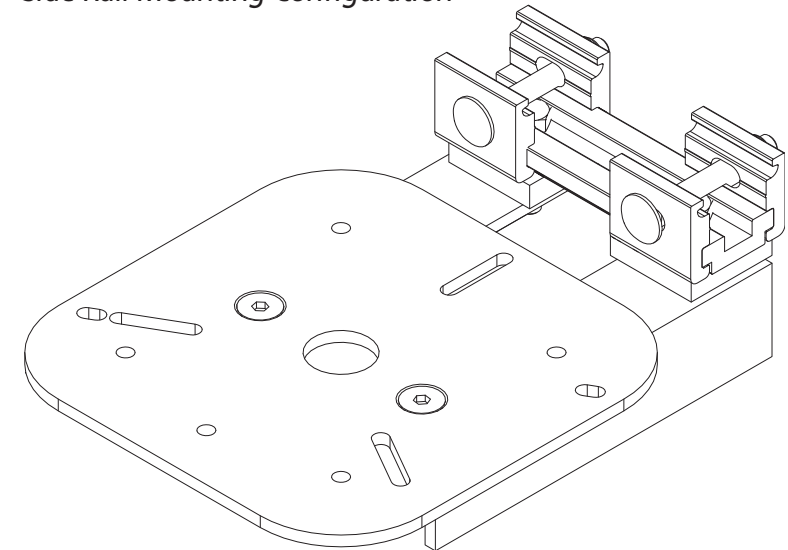

ASH-8127

Strobe/Go-Light Holder

Approximate dimensions as shown:

A: Overall Length.....	9.25"
B: Mounting Holes (2 Screws Diagonal)	6.92"
C: Mounting Circumcenter (Outer)	6.40"
D: Mounting Diameter (4 Screws)	5.65"
E: Mounting Circumcenter (Inner)	3.90"
F: Mounting Hole Spacing (Square).....	4"
G: Mounting Hole Spacing (2 Screws)	3"
H: Mounting Hole Diameter	23/64"
I: Wiring Access	7/8"
J: Screw Slot Length, Long (3 Total).....	1"
K: Mounting Hole (5 Total).....	1/4"
L: Screw Slot Length, Short (2 Total).....	5/32"
M: Mounting Plate Length/Width.....	6.75"
N: Total Holder Height	3.325"

