

# PRIME DESIGN™

A Safe Fleet Brand

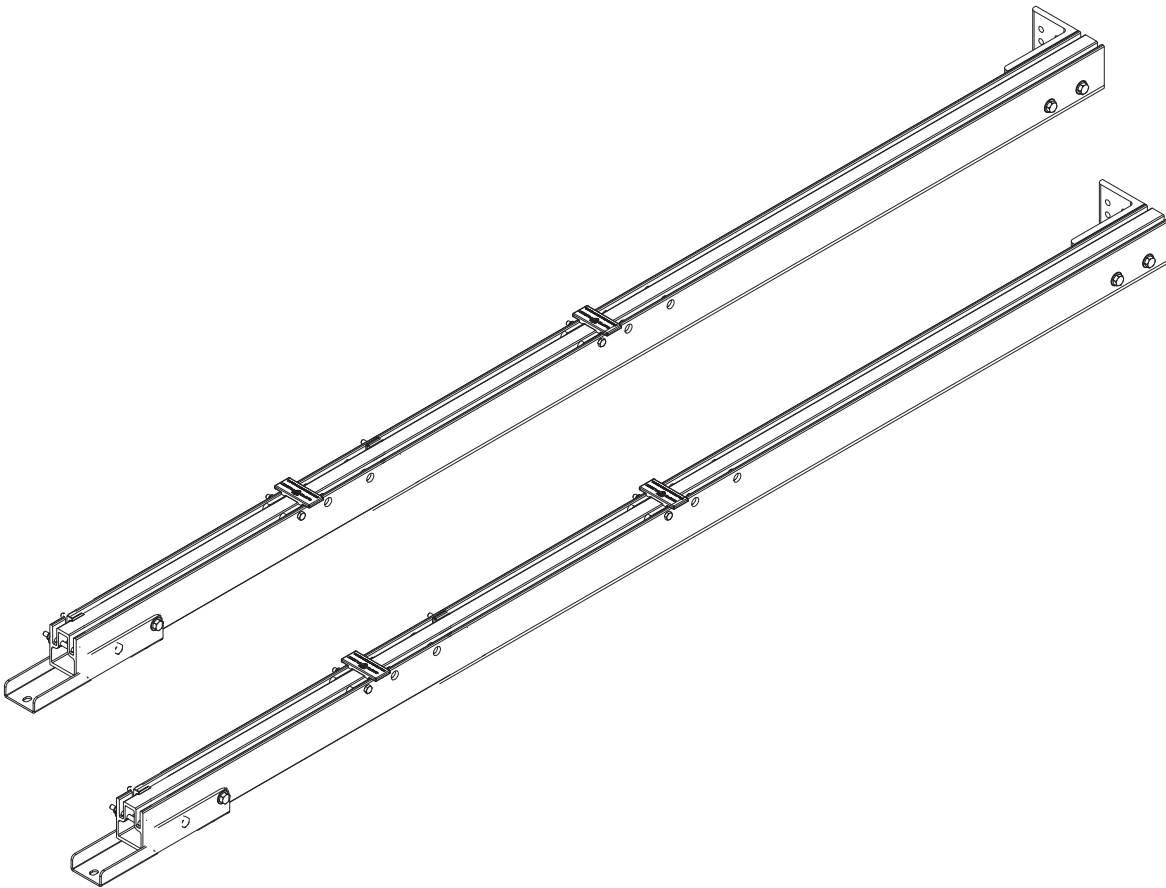

# FPU-3261

## Prime Design - FoldPro Shelving Upright Assembly

Page 2	Packaging Contents
Page 3-4	Assembly Instructions

## CONTENTS OVERVIEW

1—FoldPro Shelving Upright ..... (Qty 2)

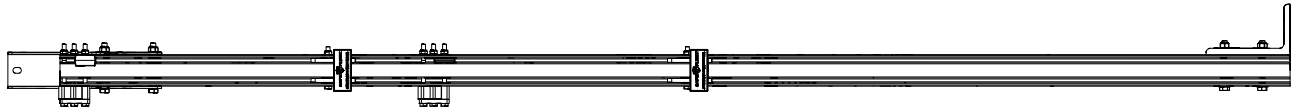

\* Check your vehicle layout configuration and OEM for correct product

2—HKT-0216 ..... (Qty 1)

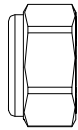

Locknut (1X)

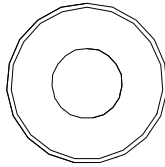

5/16 Flat Washer (2X)

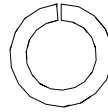

Lock Washer (1X)

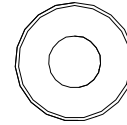

1/4 Flat Washer (2X)

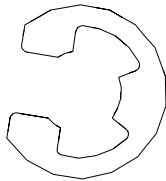

Retain Ring (16X)

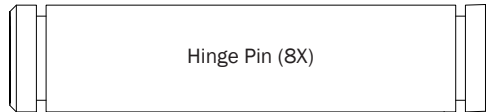

Hinge Pin (8X)

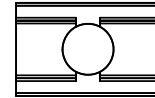

Upright Nut Bracket (4X)

## ASSEMBLY REQUIREMENTS



**INSTALLER NOTE:** *It is important to correctly follow these assembly instructions. These instructions for assembly are provided by the manufacturer at time of Cantilever Shelving delivery, and reflect the technical specifications applicable at the time of writing.*

- These instructions are subject to change if the manufacturer revises the parts and/or production of the subsystems and accessories used in the brand's vehicles. Following the instructions for assembly will ensure proper installation of the product. The manufacturer will not be held liable if these instructions are not followed.
- The addition of parts and/or components not original to this Cantilever Shelving are discouraged. Use only OEM supplied parts.
- Consultaion of the OEM vehicle may be required during assembly to avoid vehicle damage. Ensure bolt locations will not damage any critical parts of the vehicle—i.e. gas tank, wiring harnesses, or hoses-before drilling.

## RECOMMENDED TOOLS

"E-Style" Retaining Ring Applicator Tool

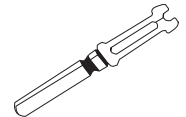

## SHELVING ASSEMBLY SEQUENCE

**0** Shelving comes packaged in pairs. For the remainder of the manual unless otherwise noted, the instructions will apply to all supports.

NOTE: For truck bodies that have an E Track or other equipment installed onto the interior walls, a spacer will need to be created in order to align the uprights and shelving correctly.

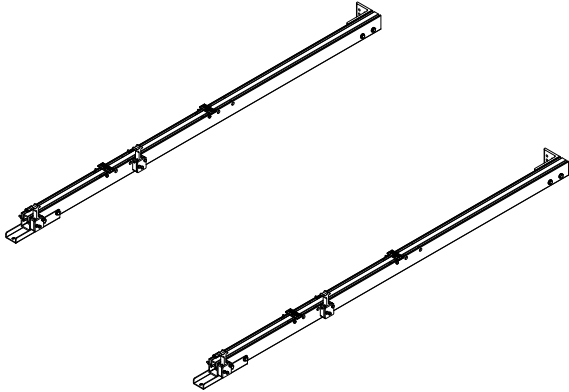

\*Product shown in views is for illustrative purposes, and may vary from your configuration. All Assembly Steps remain the same throughout this Manual.

**1** Install a Retain Ring on one side of each Hinge Pin (4 total per Upright).

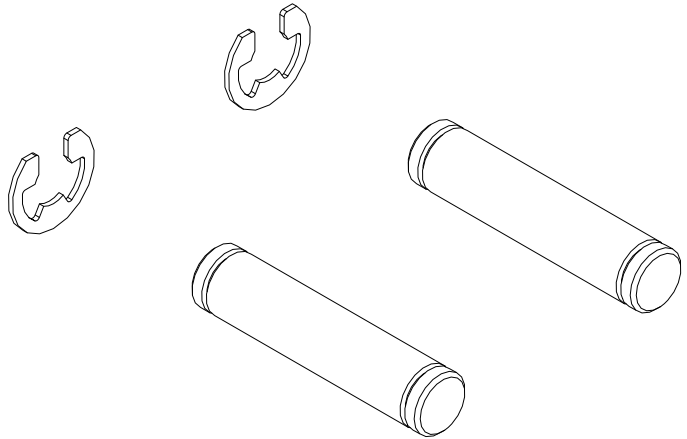

**2** Install a Hinge Pin and Retain Ring in the holes shown below.

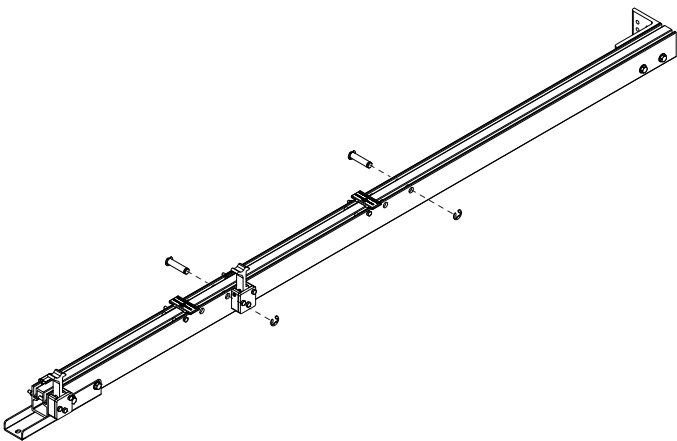

**3** Attach upper Shelving to the supports as shown.

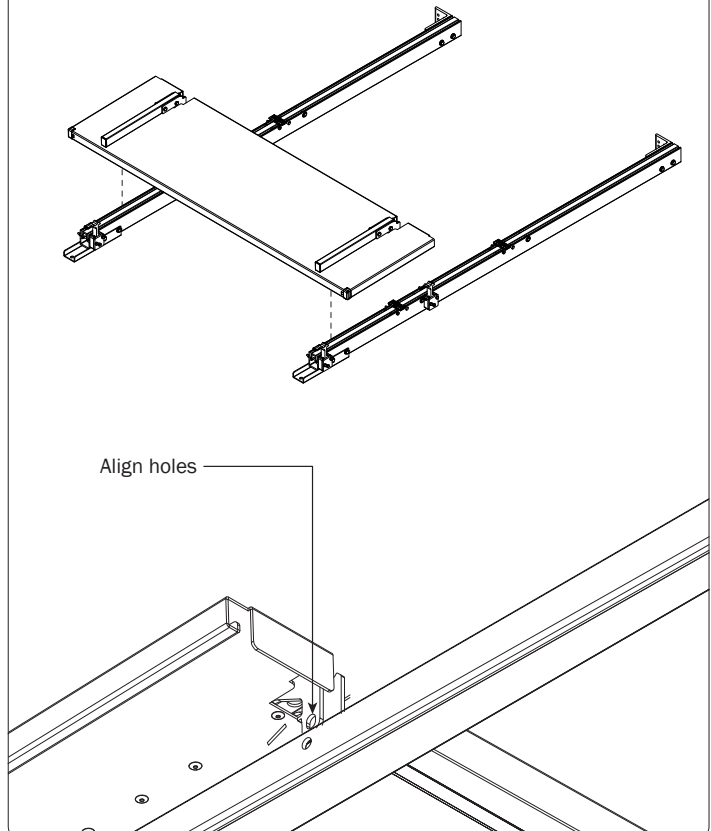

- 4 Install Hinge Pin and Retain Ring as shown.

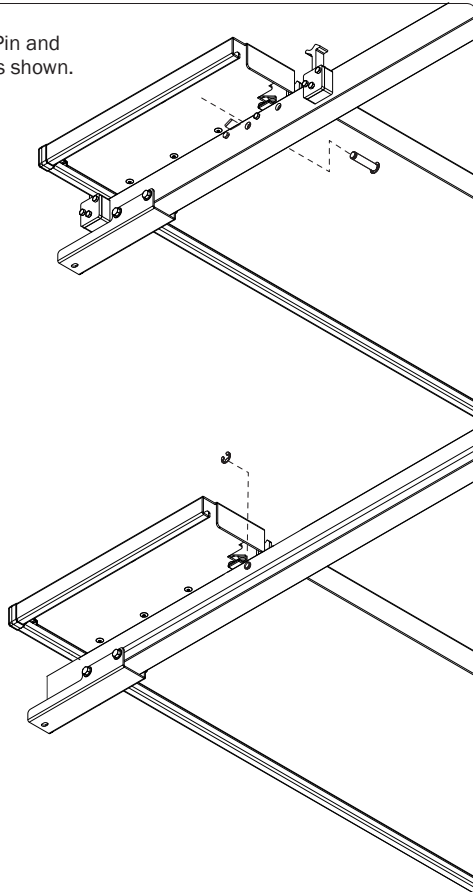

- 5 Repeat Steps 3 and 4 to install the lower Shelf.

- 6 Attach to body utilizing top wall to roof extrusion as shown below using OEM hardware.

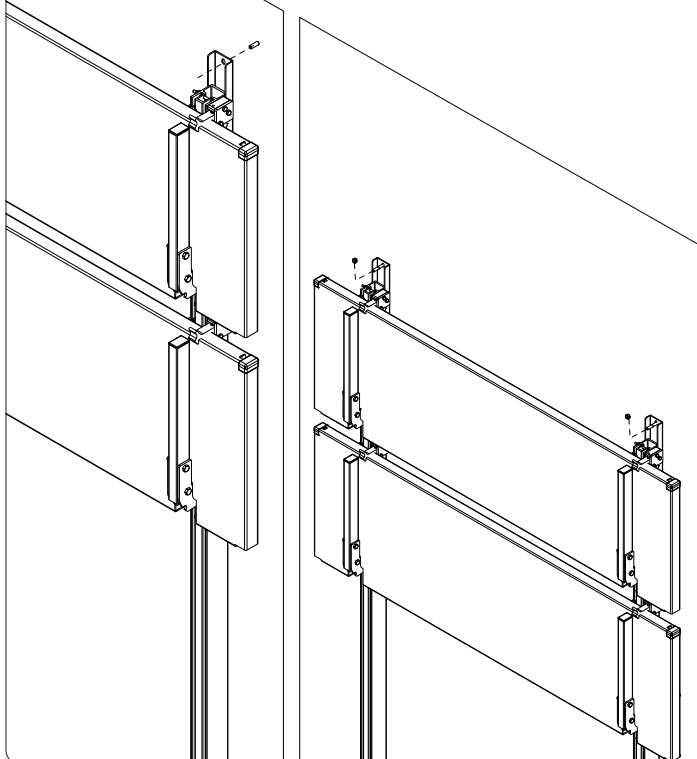

- 7 Upright feet are customizable for drilling locations and positioning. Install hardware according to your vehicle OEM. Insert upright nut bracket into channel and use bolt and hardware to attach mounting foot to upright.

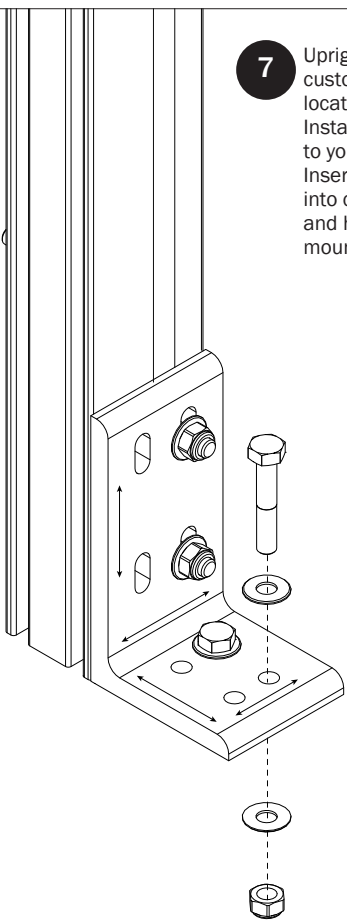

- 8 The Shelving Lock is engaged when shelving is open, to disengage and close Shelving, slide lock in and up as shown.

Refer to your Cantilever Shelving Mounting Assembly Manual to mount shelving to your vehicle.

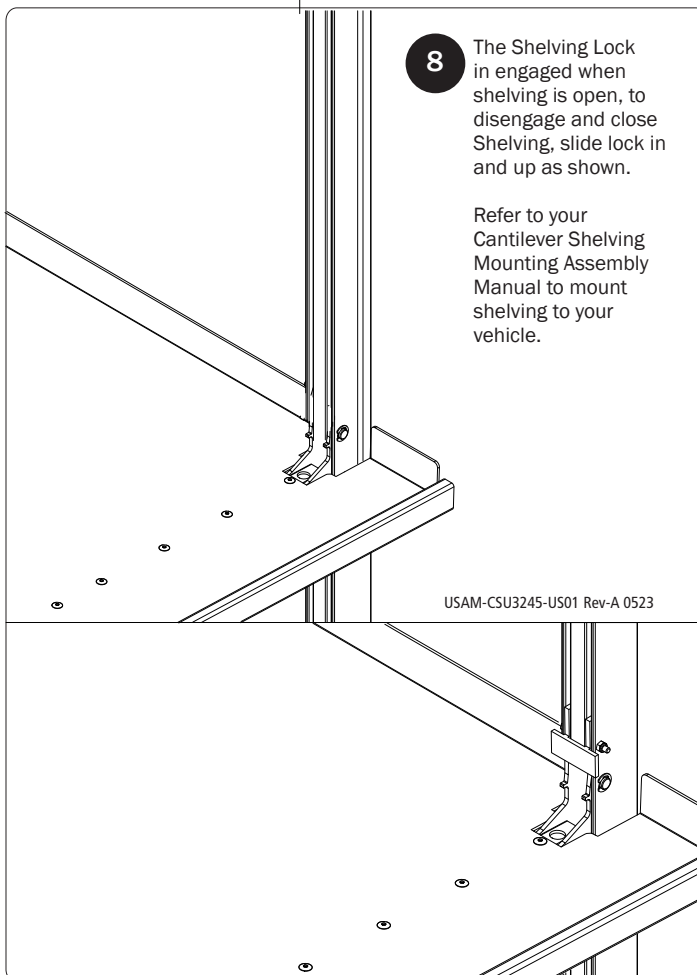

USAM-CSU3245-US01 Rev-A 0523