

PRIME DESIGN™

A Safe Fleet Brand

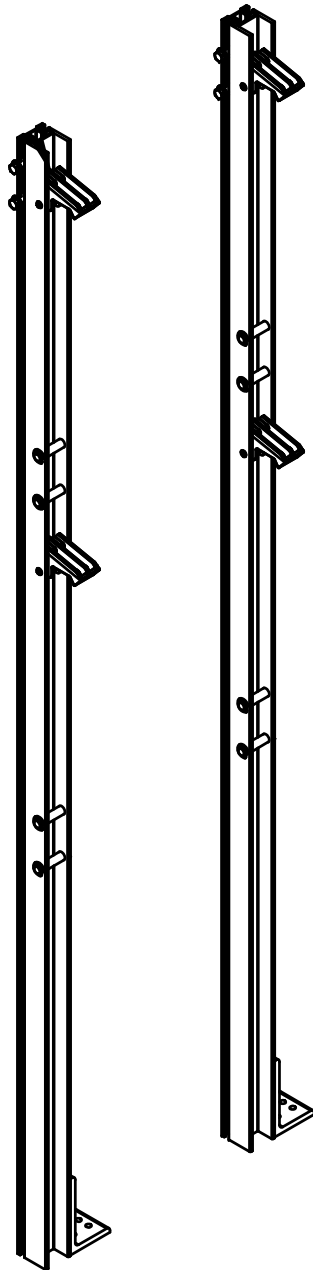

FPU-3270

Prime Design - FoldPro Shelving Upright Assembly

Page 2	Packaging Contents
Page 3-4	Assembly Instructions

CONTENTS OVERVIEW

1—FoldPro Shelving Upright (Qty 2)

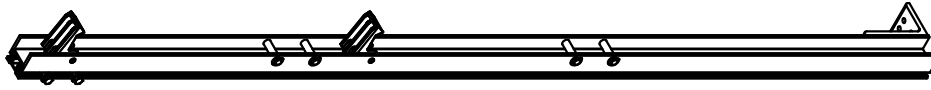

* Check your vehicle layout configuration and OEM for correct product

2—AV-1019 (Qty 2)

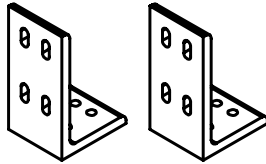

3—HKT-0219 (Qty 1)

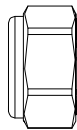

Locknut (1X)

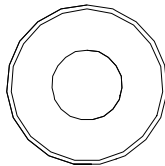

5/16 Flat Washer (2X)

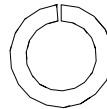

Lock Washer (1X)

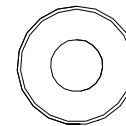

1/4 Flat Washer (2X)

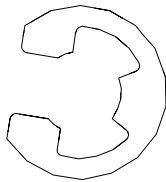

Retain Ring (16X)

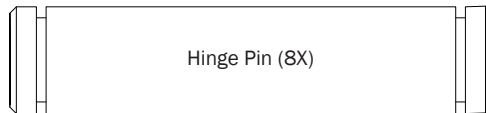

Hinge Pin (8X)

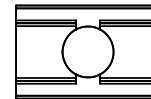

Upright Nut Bracket (4X)

ASSEMBLY REQUIREMENTS



INSTALLER NOTE: *It is important to correctly follow these assembly instructions. These instructions for assembly are provided by the manufacturer at time of Cantilever Shelving delivery, and reflect the technical specifications applicable at the time of writing.*

- These instructions are subject to change if the manufacturer revises the parts and/or production of the subsystems and accessories used in the brand's vehicles. Following the instructions for assembly will ensure proper installation of the product. The manufacturer will not be held liable if these instructions are not followed.
- The addition of parts and/or components not original to this Cantilever Shelving are discouraged. Use only OEM supplied parts.
- Consultation of the OEM vehicle may be required during assembly to avoid vehicle damage. Ensure bolt locations will not damage any critical parts of the vehicle—i.e. gas tank, wiring harnesses, or hoses—before drilling.

RECOMMENDED TOOLS

"E-Style" Retaining Ring Applicator Tool

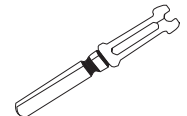

SHELVING ASSEMBLY SEQUENCE

- 0 Insert nut brackets into side upright channel and install required top mounting bracket (FPM) using provided hardware.

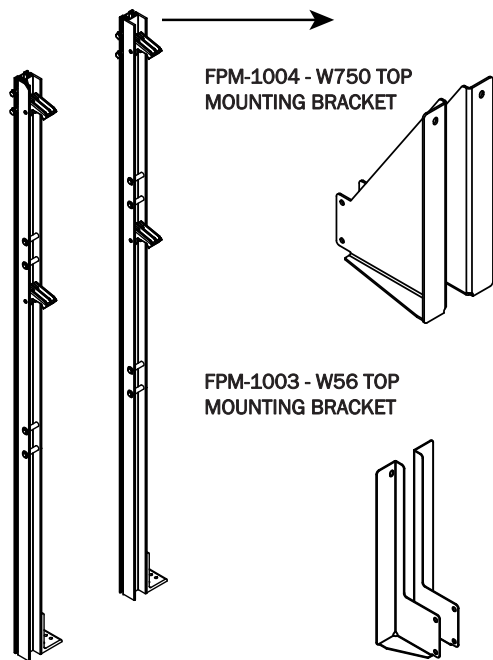

*Product shown in views is for illustrative purposes, and may vary from your configuration. All Assembly Steps remain the same throughout this Manual.

- 1 Insert small nut bracket into side upright channel and mount bottom floor bracket using provided hardware.

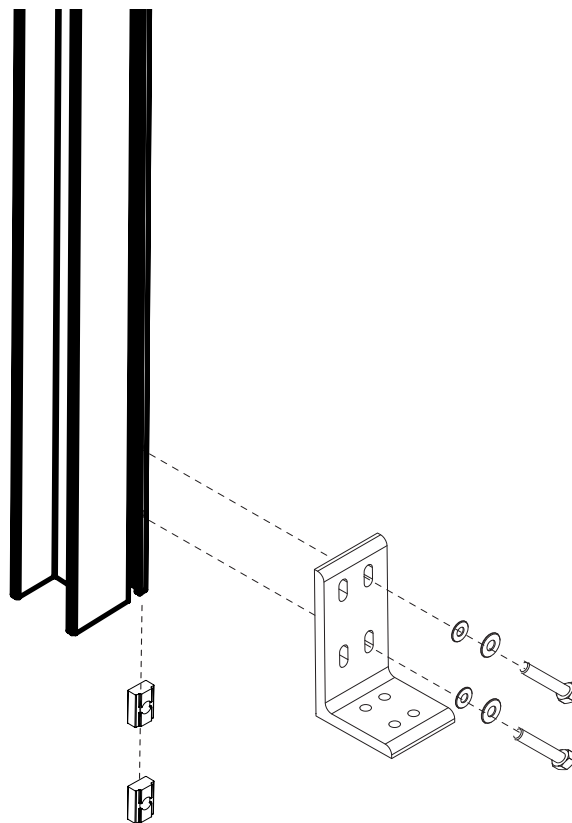

- 2 Install a retain ring on one side of each hinge pin. Then, insert Hinge Pin and Retain Ring in the lower holes shown below.

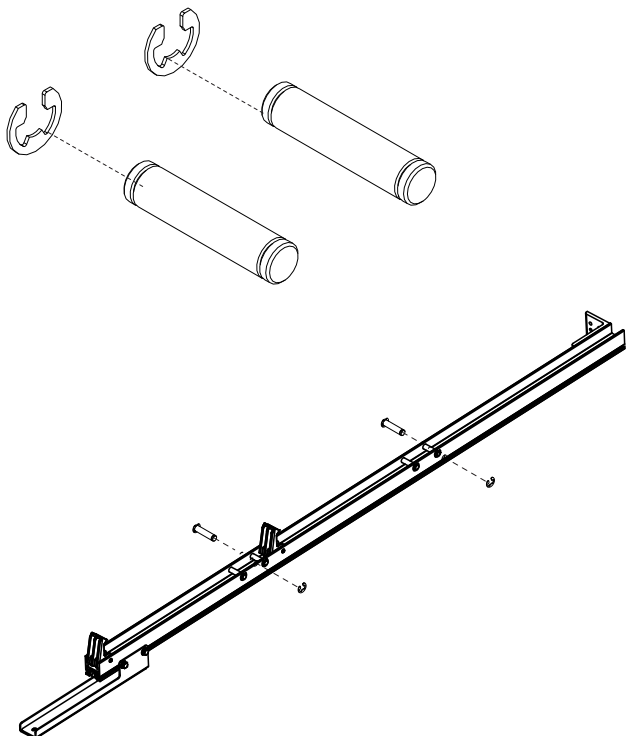

- 3 Attach upper Shelving to the supports as shown.

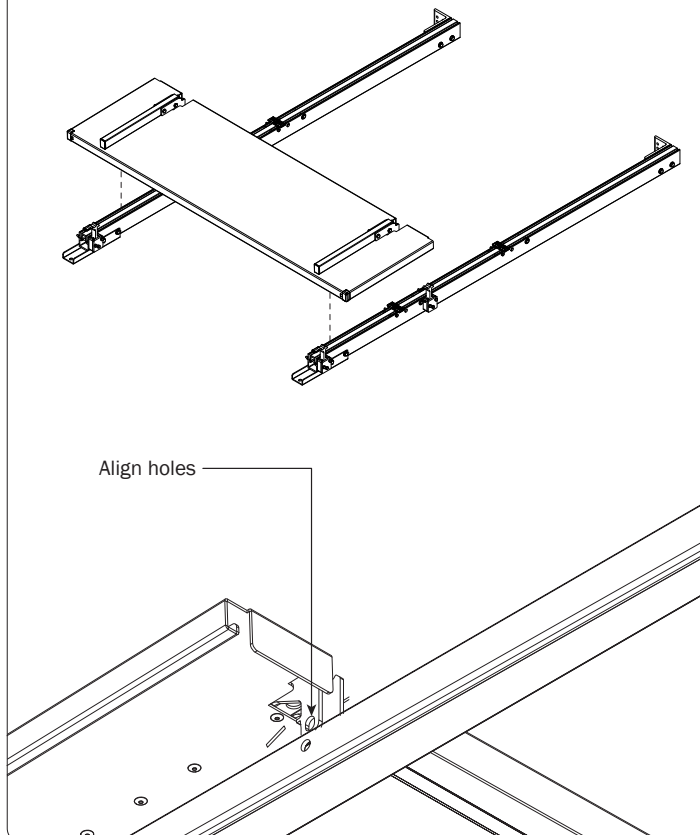

- 4** Install Hinge Pin and Retain Ring as shown.

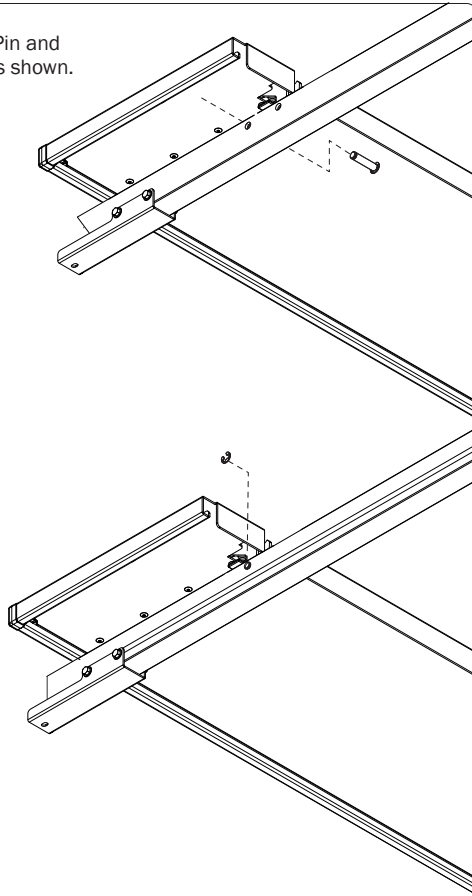

- 5** Repeat Steps 3 and 4 to install the lower Shelf.

- 6** Attach to body utilizing top wall to roof extrusion as shown below using OEM hardware.

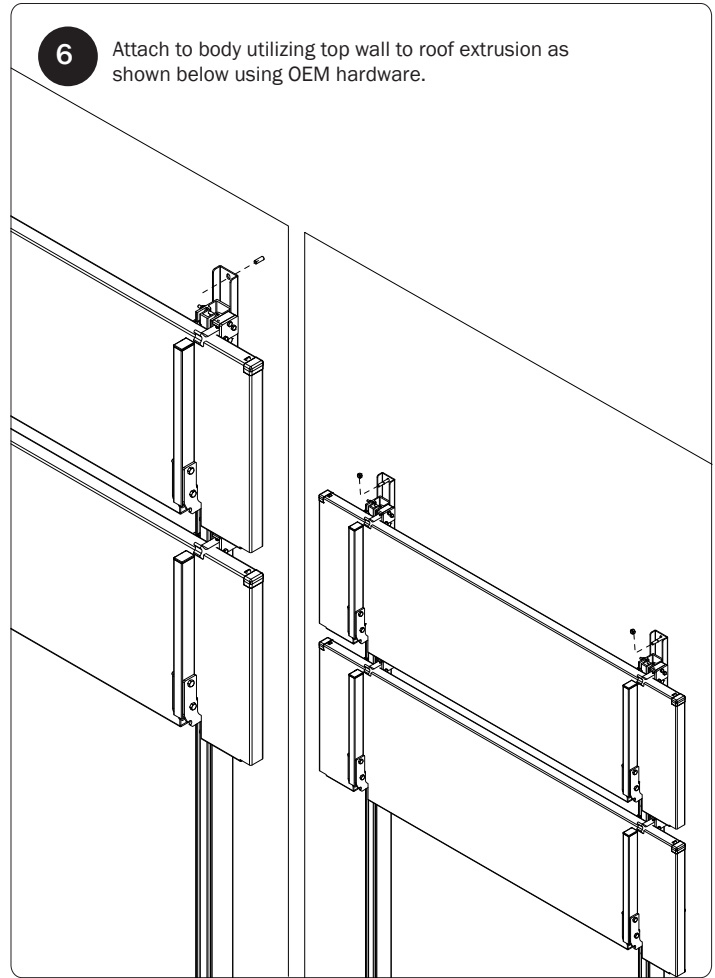

- 7** Upright feet are customizable for drilling locations and positioning. Install hardware according to your vehicle OEM. Insert upright nut bracket into channel and use bolt and hardware to attach mounting foot to upright.

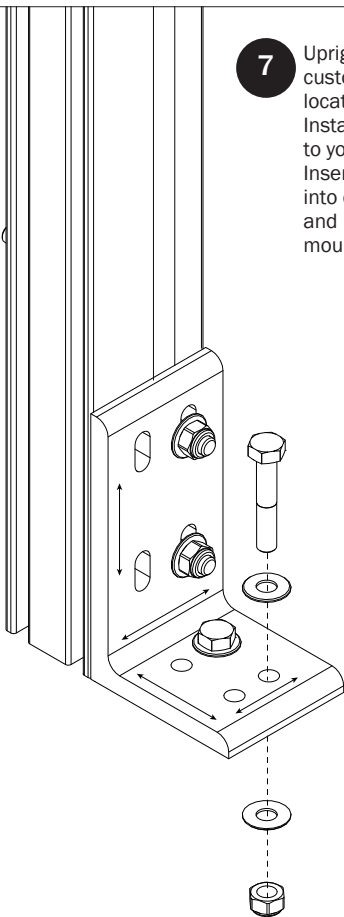

- 8** When fully open or closed shelf latches will "lock" shelf in place. To disengage simply pull out with one or both hands and position the shelf in the desired position.

Refer to your FoldPro Shelving Mounting Assembly Manual to mount shelving to your vehicle.

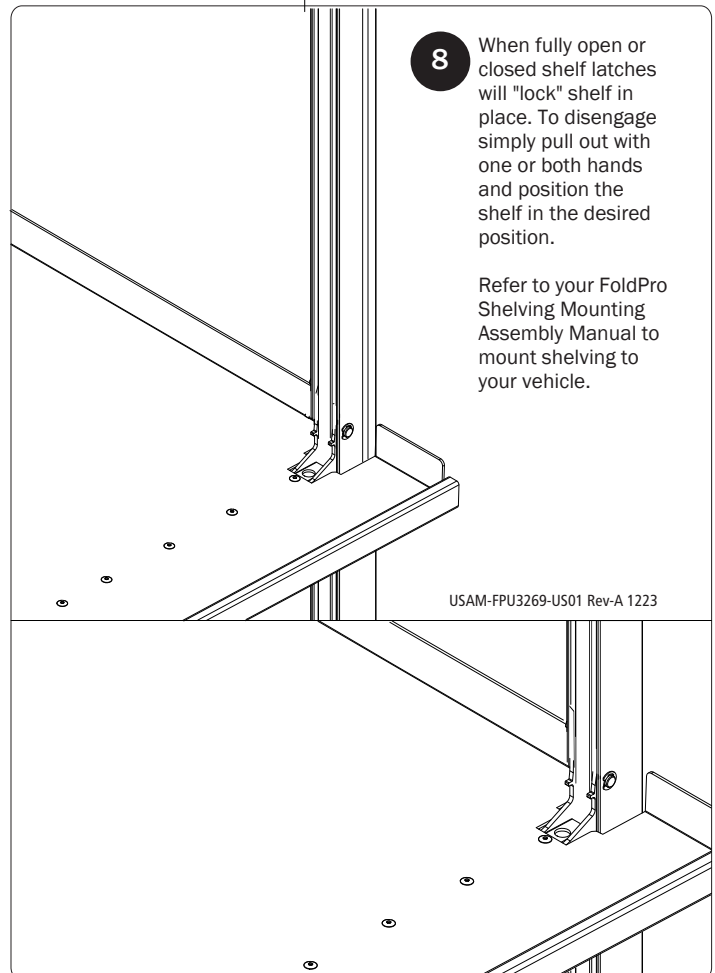

USAM-FPU3269-US01 Rev-A 1223